

**märklin**  
Z

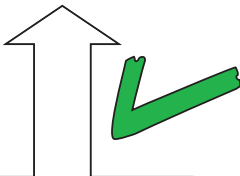
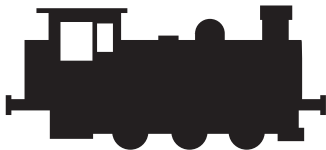

Modell der Elektrolokomotive BR 185.2

**88486**

A voltmeter with a scale from 0 to 200 in both directions. The needle is positioned at 10. The text "0 - 10 V" is printed at the top of the meter's face.

max.  $\pm 10 \text{ V} = \text{DC}$

A voltmeter with a scale from 0 to 200 in both directions. The needle is positioned at 10. The text "> 10 V = DC" is printed below the meter.

> 10 V = DC

A voltmeter with a scale from 0 to 200 in both directions. The needle is positioned at 10. The text "~ AC" is printed below the meter.

~ AC

### **Sicherheitshinweise**

- **ACHTUNG!** Funktionsbedingte scharfe Kanten und Spitzen.
- Das verwendete Gleisanschlusskabel darf maximal 2 Meter lang sein.
- Verbaute LED`s entsprechen der Laserklasse 1 nach Norm EN 60825-1.

### **Allgemeiner Hinweis zur Vermeidung elektromagnetischer Störungen:**

Um den bestimmungsgemäßen Betrieb zu gewährleisten, ist ein permanenter, einwandfreier Rad-Schiene-Kontakt der Fahrzeuge erforderlich. Führen Sie keine Veränderungen an stromführenden Teilen durch.

### **Safety Notes**

- **WARNING!** Sharp edges and points required for operation.
- The wire used for feeder connections to the track may be a maximum of 2 meters / 78 inches long.
- The LEDs in this item correspond to Laser Class 1 according to Standard EN 60825-1.

### **General Note to Avoid Electromagnetic Interference:**

A permanent, flawless wheel-rail contact is required in order to guarantee operation for which a model is designed. Do not make any changes to current-conducting parts.

### **Remarques importantes sur la sécurité**

- **ATTENTION !** Pointes et bords coupants lors du fonctionnement du produit.
- Le câble de raccordement à la voie utilisé ne doit en aucun cas dépasser deux mètres.
- Les DEL installées correspondent à la classe laser 1 selon la norme EN 60825-1.

### **Indication d'ordre général pour éviter les interférences électromagnétiques:**

La garantie de l'exploitation normale nécessite un contact roue-rail permanent et irréprochable. Ne procédez à aucune modification sur des éléments conducteurs de courant.

### **Veiligheidsvoorschriften**

- **OPGEPAST!** Functionele scherpe kanten en punten.
- De gebruikte aansluitkabel mag maximaal 2 meter lang zijn.
- Ingebouwde LED's komen overeen met de laserklasse 1 volgens de norm EN 60825-1.

### **Algemene aanwijzing voor het vermijden van elektromagnetische storingen:**

Om een betrouwbaar bedrijf te garanderen is een permanent, vlekkeloos wielas - rail contact van het voertuig noodzakelijk. Voer geen wijzigingen uit aan de stroomvoerende delen.

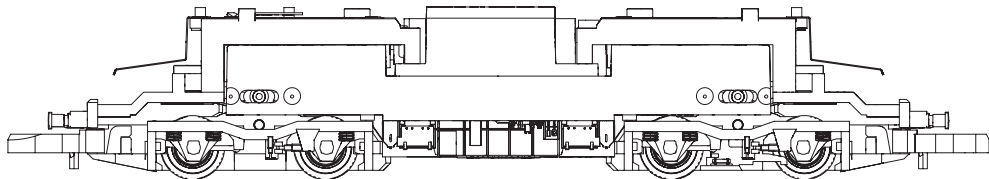
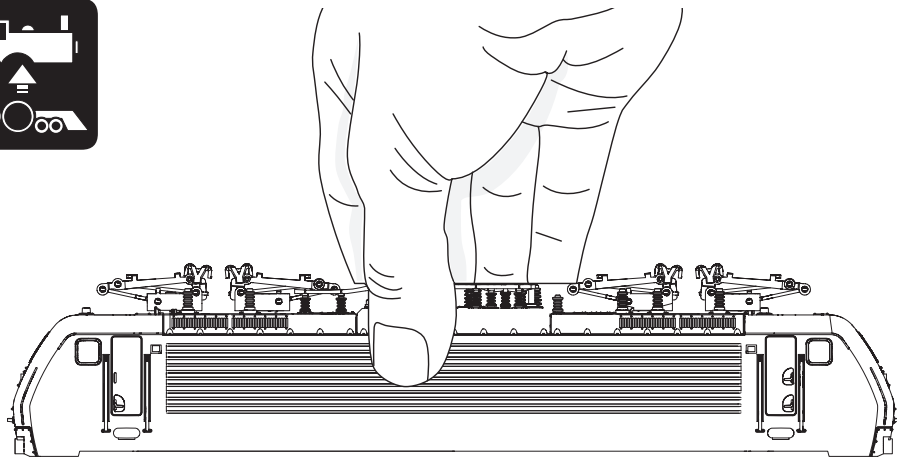

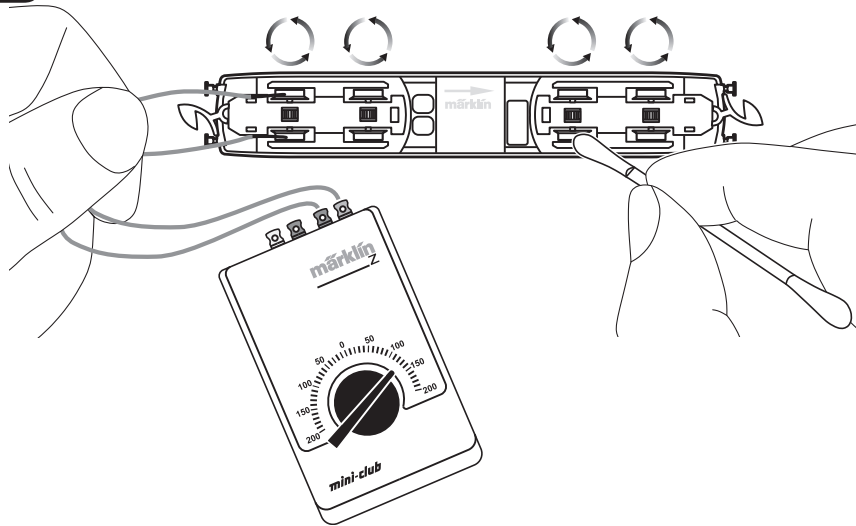
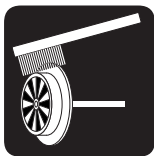

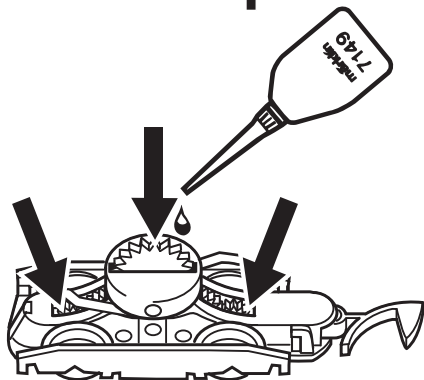
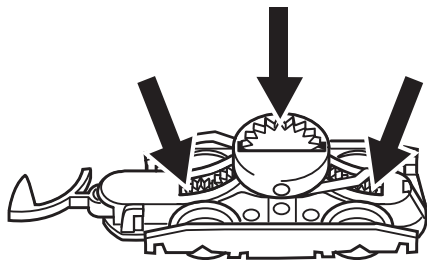
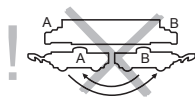
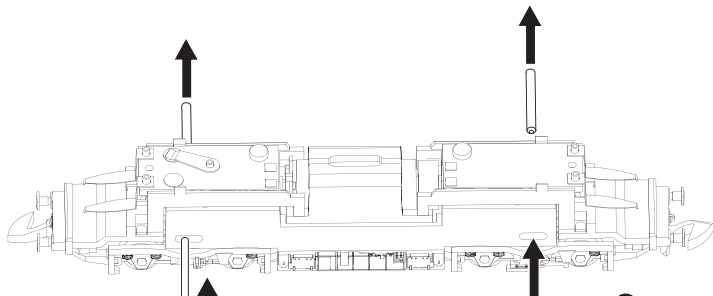

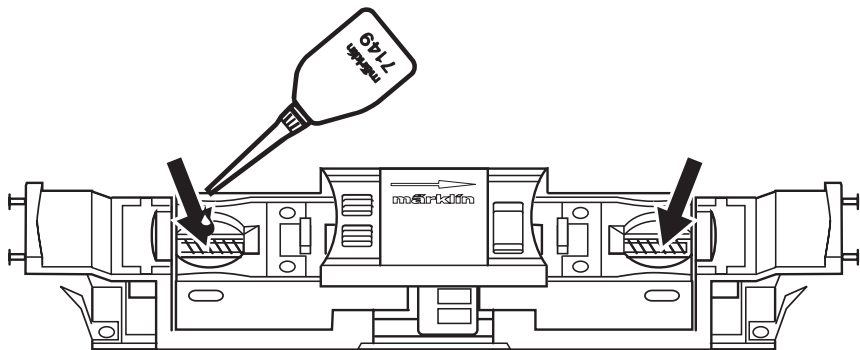

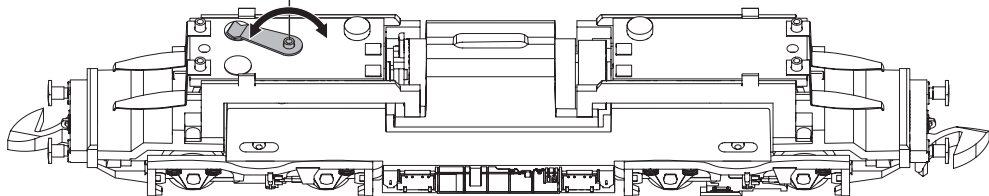
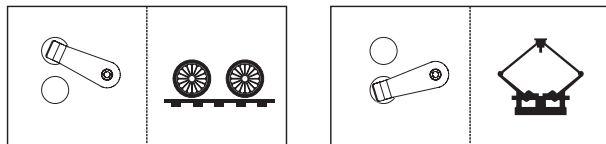
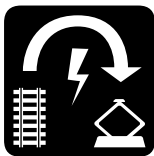





Bei Oberleitungsbetrieb Pfeil beachten!

To operate the catenary system follow the direction indicated by the arrow.

Pour utilisation de la caténaire tenir compte de la flèche.

Bij gebruik van bovenleiding op pijl letten!

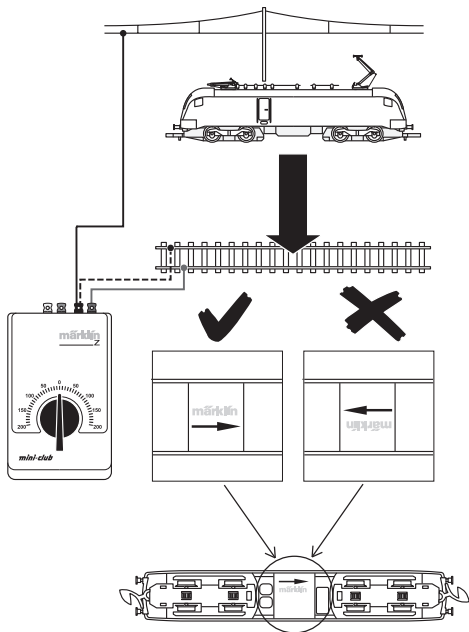

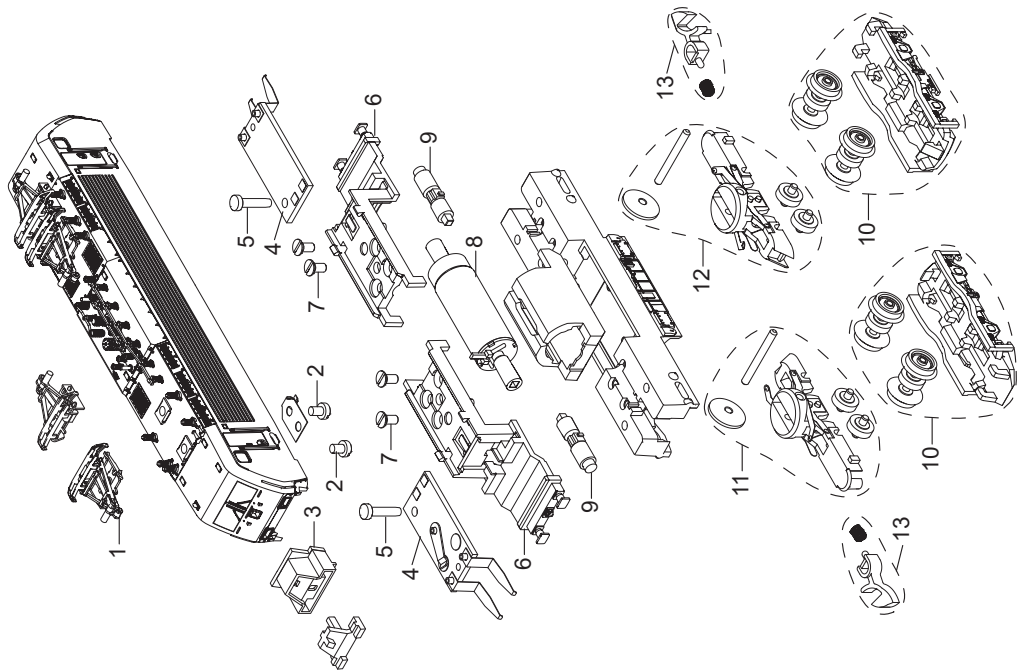

1	Stromabnehmer	E310 727
2	Schraube	E785 150
3	Beleuchtungseinheit	E175 875
4	Leiterplatte	E287 568
5	Schraube	E232 042
6	Isolierung mit Pufferbohle	E291 113
7	Schraube	E232 043
8	Motor	E291 665
9	Antriebswelle	—
10	Drehgestellrahmen, Radsätze	E292 887
11	Getriebegehäuse vorn komplett	E181 613
12	Getriebegehäuse hinten komplett	E181 614
13	Kupplung	E166 264

Einige Teile werden nur ohne oder mit anderer Farbgebung angeboten.

Teile, die hier nicht aufgeführt sind, können nur im Rahmen einer Reparatur im Märklin-Reparatur-Service repariert werden.

Details der Darstellung können von dem Modell abweichen.

Several parts are offered unpainted or in another color.

Parts that are not listed here can only be repaired by the Märklin repair service department.

Details in the image may differ from the model.

Certains éléments sont proposés uniquement sans livrée ou dans une livrée différente.

Les pièces ne figurant pas dans cette liste peuvent être réparées uniquement par le service de réparation Märklin.

Sur le dessin, certains détails peuvent différer du modèle.

Enkele delen worden alleen kleurloos of in een andere kleur aangeboden.

Delen die niet in de in de lijst voorkomen, kunnen alleen via een reparatie in het Märklin-service-centrum hersteld/ vervangen worden.

Details in de tekening kunnen afwijken van het model.



  
[www.maerklin.com/en/imprint.html](http://www.maerklin.com/en/imprint.html)



FR

La locomotive  
se recycle

À DÉPOSER  
EN MAGASIN



OU

À DÉPOSER  
EN DÉCHÈTERIE



Points de collecte sur [www.quefairedemesdechets.fr](http://www.quefairedemesdechets.fr)



FR



Gebr. Märklin & Cie. GmbH  
Stuttgarter Str. 55 - 57  
73033 Göppingen  
Germany  
[www.maerklin.com](http://www.maerklin.com)

375817/1122/Sm1Ef  
Änderungen vorbehalten  
© Gebr. Märklin & Cie. GmbH