

Heller

RENAULT 4 TL/GTL

80759



DÉCOUVREZ LE MONDE DES PEINTURES ACRYLIQUES HELLER !

DISCOVER THE WORLD OF HELLER ACRYLIC PAINTS!
ENTDECKEN SIE DIE WELT DER HELLER ACRYL-FARBEN!



NEW

- FACILE À UTILISER
- DILUABLE À L'EAU
- POTS DE PEINTURE STABLES
- BOUCHON À VIS SÉCURISÉ
- EASY TO USE
- DILUTABLE WITH WATER
- STABLE PAINT CANS
- SECURE SCREW CAP
- EINFACHE ANWENDUNG
- MIT WASSER VERDÜNNBAR
- STANDFESTE FARBDOSEN
- SICHERER SCHRAUBVERSCHLUSS

Français

Lorsque la nouvelle petite Renault apparaît au salon de Paris à la fin 1961, il s'agit d'une petite révolution ! Le constructeur au losange dévoile un nouveau concept, une nouvelle façon d'aborder l'automobile. Tout dans la Renault 4 est révolutionnaire pour une voiture de son segment. On trouve un quatre cylindres économique avec un circuit de refroidissement scellé sans entretien, une traction avant (une première chez Renault sur une voiture de tourisme), une plate-forme sur laquelle est boulonnée la carrosserie, quatre roues à suspension indépendante, quatre véritables places avec des banquettes AV et AR amovibles, et surtout un hayon qui facilite grandement le chargement du coffre. Dès son premier millésime 1962, la limousine 6 glaces va être appelée R4L en opposition aux modèles de base R3 et R4. Dès lors dans l'esprit de tous, la Renault 4 va demeurer une « 4L » quelle que soit sa finition ou les appellations officielles choisies par le constructeur. Il va en être ainsi jusqu'à sa disparition en décembre 1992. Ce seront donc plus de trente ans de carrière pour une des plus grandes réussites automobiles nationales. Et plus de huit millions d'exemplaires vendus à travers le monde. Le modèle GTL connaîtra un grand succès lors de sa présentation en 1978. Ce nouveau modèle permet à la Renault 4 de se faufiler dans le trafic moderne d'alors. Pour y parvenir elle peut compter sur un moteur 1108 cm3 de 34 ch DIN et une boîte de vitesses à quatre rapports bien étagée. La GTL coûte 19 200 francs et va vite s'imposer comme la meilleure des Renault 4 jamais commercialisée.

English

When the new little Renault first appeared at the Paris Auto Show in late 1961, it was hailed as revolutionary! There, the manufacturer with the diamond logo not only unveiled a new concept, but also a new approach to the automobile. Everything in the Renault 4 was revolutionary for a car in its segment. This four-cylinder economy car with a sealed, maintenance-free cooling circuit boasted front-wheel drive (a first for Renault on a passenger car), a platform to which the body was bolted, four wheels with independent suspension, four full seats with removable front and rear bench seats, and most especially a hatchback which greatly facilitated the loading of the boot. With the release of its first models in 1962, the six side window limousine version was named the R4L, as opposed to the basic R3 and R4 models. In fact, when the public hears "Renault 4", a "4L" model generally comes to mind, regardless of its finish or the official designations chosen by the manufacturer. This was the case until the end of the model's production in December 1992. Over its thirty-year career as one of France's greatest domestic automobile success stories, more than eight million vehicles were sold worldwide. The GTL model met with success upon its release in 1978. This new model enabled the Renault 4 to better fit into that era's auto manufacturing landscape. To achieve this, it relied on a 1108 cm3 engine generating 34 hp and a gearbox with four well-spaced gears. The GTL cost 19,200 francs and soon established itself as the best Renault 4 ever marketed.

Nombre de cylindres	4 en ligne
Cylindrée	1108 cm3
Alimentation	un carburateur
Puissance	34 ch DIN
Nombre de vitesses	4 + marche arrière
Longueur	3,67 m
Largueur	1,48 m
Vitesse maxi	122 km/h

Number of cylinders	4 in line
Displacement	1108 cm3
Feed	carburettor
Power	34 hp
Number of gear ratios	4 + reverse
Length	3.67 m
Width	1.48 m
Maximum speed	122 km/h

Deutsch

Als der neue Renault-Kleinwagen Ende 1961 auf dem Pariser Salon vorgestellt wird, bedeutet das eine kleine Revolution! Der Konstrukteur der Marke enthüllt ein neues Konzept: eine ganz neue Herangehensweise an das Automobil. Der gesamte Renault 4 ist revolutionär für sein Segment. Er hat einen sparsamen Vierzylindermotor mit einem plombierten, wartungsfreien Kühlsystem, Vorderradantrieb (eine Premiere bei Renault für Personenkraftwagen), einen Plattformrahmen, auf dem die Karosserie verschraubt ist, vier Räder mit voneinander unabhängiger Aufhängung, vier komplett nutzbare, vorn und hinten feste Sitzplätze und vor allem eine Heckklappe, die den Zugang zum Kofferraum deutlich erleichtert. Der erste Jahrgang der Limousine mit 6 Fenstern erscheint 1962 und wird „R4L“ genannt, um sie von den Basismodellen R3 und R4 zu unterscheiden. Im kollektiven Gedächtnis bleibt der Renault 4 aber als „4L“, egal welche Ausführungen und offiziellen Namen er auch vom Konstrukteur erhält. Das wird bis zu seiner Einstellung im Dezember 1992 auch so bleiben. Er macht als einer der größten französischen Automobil-Erfolge mehr als dreißig Jahre lang Karriere und verkauft sich mehr als acht Millionen mal weltweit. Das Modell GTL feiert nach seiner Präsentation 1978 große Erfolge. Das neue Modell ist ein Renault 4, der sich mühelos durch den modernen Verkehr schlängelt. Dafür bringt er einen neuen Motor mit 1.108 cm³ und 34 DIN-PS und ein Schaltgetriebe mit vier gut angeordneten Gängen mit. Der GTL kostet 19.200 französische Francs und etabliert sich schnell als der beste jemals verkaufte Renault 4.

Español

¡Este nuevo utilitario de Renault causa furor durante su presentación en el salón del automóvil de París a finales de 1961! El fabricante del logotipo en forma de rumbero revela un diseño totalmente nuevo que supone un novedoso enfoque en la manera en que hasta ahora se contemplaba al automóvil. De hecho, todo en el Renault 4 es revolucionario si se compara con los demás automóviles de su segmento existentes por entonces. Incorporaba un motor de cuatro cilindros de escaso consumo, equipado con un circuito de refrigeración de tipo cerrado y libre de mantenimiento, tracción delantera (la primera berlina de Renault en adoptar esta configuración), un chasis tipo plataforma sobre el que iba atornillada la carrocería, suspensión independiente en las cuatro ruedas, cuatro cómodas plazas con asientos delanteros y traseros tipo banqueta (la trasera abatible) y, en particular, un amplio portón trasero que facilitaba enormemente la carga y descarga en el maletero. Desde el primer momento en que irrumpió en el mercado allá por 1962, esta berlina de 6 cristales pasaría a conocerse comúnmente como "R4L", a fin de diferenciarla de los modelos básicos R3 y R4. Desde entonces y en boca de todos, el Renault 4 seguirá conociéndose como 4L o cariñosamente "cuatro latas" independientemente de las variantes de modelo o denominaciones oficiales elegidas por el fabricante, y así continuará hasta que finalmente deja de fabricarse en diciembre de 1992. La producción de uno de los mayores éxitos automovilísticos nacionales abarcará más de treinta años, con más de 8 millones de unidades vendidas en todo el mundo. El modelo GTL tendrá un gran éxito durante su presentación en 1978. Este nuevo modelo hace posible que el Renault 4 encaje en el mercado de vehículos modernos existentes por entonces. Para ello, se le dota de un motor de 1108 cm³ de 34 CV-DIN y una caja de cambios de cuatro velocidades con excelentes relaciones de desmultiplicación. El modelo GTL cuesta originalmente 19 200 francos franceses y pasa rápidamente a consolidarse como el mejor Renault 4 comercializado hasta la fecha.

Italiano

Quando la nuova piccola Renault viene presentata al salone di Parigi alla fine del 1961, è una vera piccola rivoluzione! Il costruttore dal famoso logo romboidale svela un nuovo concept fondato su un nuovo modo di concepire l'automobile. Per un'automobile di quel segmento, tutto è rivoluzionario nella Renault 4: una quattro cilindri economica con un circuito di raffreddamento saldato senza trattamento, una trazione anteriore (una novità assoluta in Renault per un'automobile da turismo), una piattaforma su cui è fissata a bulloni la carrozzeria, quattro ruote a sospensioni indipendenti, quattro posti effettivi con sedili anteriori e posteriori ribaltabili, e soprattutto uno sportello posteriore che facilita il caricamento del bagagliaio. La prima versione lusso viene lanciata nel 1962, una limousine a 6 finestrini ribattezzata R4L per differenziarla dai modelli base R3 e R4. Da allora, per tutti la Renault 4 diviene «4L» qualunque siano le specifiche dei diversi modelli. E sarà così per decenni fino alla sua scomparsa dal mercato nel dicembre 1992. Più di trent'anni di carriera dunque, per uno dei più grandi successi dell'industria automobilistica francese. E più di otto milioni di esemplari venduti in tutto il mondo. Il modello GTL conosce un vasto successo sin dalla sua presentazione nel 1978, una nuova versione più grintosa che permetterà alla Renault 4 di districarsi nel traffico moderno per tanti anni a venire. Per garantire prestazioni così dinamiche, l'auto può contare su un motore 1108 cm³ da 34 ch DIN e quattro rapporti scattanti. La GTL costa 19.200 franchi e diviene presto una delle Renault 4 più vendute di sempre.

Nederlands

Toen de nieuwe kleine Renault zijn opwachting maakte op het salon van Parijs eind 1961, vond er een kleine revolutie plaats! De autofabrikant met het ruitenlogo onthulde een nieuw concept, een nieuwe benaderingswijze van de auto. Alles in de Renault 4 was revolutionair voor een voertuig binnen zijn segment. De auto was voorzien van vier zuinige cilinders met een onderhoudsvrij en afgedicht koelsysteem, voorwielaandrijving (als eerste personenauto bij Renault), een platform waarop de carrosserie is vastgeklinkt, vier wielen met afzonderlijke ophanging, vier degelijke zitplaatsen met afneembare voor- en achterbank, en in het bijzonder een vijfde deur om de koffer eenvoudiger te kunnen laden. De limousine met 6 ruiten kreeg reeds vanaf het begin, in 1962, de naam R4L, dit in tegenstelling tot de basismodellen R3 en R4. Aansluitend op dit alles, kreeg de Renault 4 de naam "4L", ongeacht zijn afwerking of officiële benamingen die door de fabrikant werden gekozen. De auto werd tot december 1992 op de markt gebracht. Dit is een carrière van meer dan 30 jaar voor een van de grootste nationale successen op autobebied. Er zijn meer dan 8 miljoen exemplaren over de hele wereld verkocht. Het model GTL kende een groot succes vanaf zijn introductie in 1978. Dit nieuwe model zorgde ervoor dat de Renault 4 zich perfect kon integreren in het moderne verkeer van die tijd. De auto kon rekenen op een 1108 cm³ motor met 34 DIN PK en een versnellingsbak met vier versnellingen die trapsgewijs schakelen. De prijs van de GTL was 19.200 Franse Frank en de auto werd snel aanzien als de beste Renault 4 die ooit op de markt werd gebracht.

Anzahl der Zylinder	4, in Reihe
Hubraum	1.108 cm ³
Versorgung	Vergaser
Leistung	34 DIN-PS
Anzahl der Gänge	4 + Rückwärtsgang
Länge	3,67 m
Breite	1,48 m
Höchstgeschwindigkeit	122 km/h

Número de cilindros	4 en línea
Cilindrada	1108 cm ³ .
Sistema de alimentación	carburador
Potencia	34 CV-DIN
Número de velocidades	4 y marcha atrás
Longitud	3,67 m
Ancho	1,48 m
Velocidad máxima	122 km/h

Numero di cilindri	4 in linea
Cilindrata	1108 cm ³
Alimentazione	un carburatore
Potenza	34 ch DIN
Numero di marce	4 + retromarcia
Lunghezza	3,67 m
Larghezza	1,48 m
Velocità massima	122 km/h

Aantal cilinders	4 op een rij
Cilinderinhoud	1108 cm ³
Voeding	een carburator
Vermogen	34 DIN PK
Aantal versnellingen	4 + achteruit
Lengte	3,67 m
Breedte	1,48 m
Maximum snelheid	122 km/u

2

Número de phase
Step number
Schrittnummer
Número de fase

56

Référence de couleur
Colour reference no
Farbangabe
Referencia de color

37

Número de pièce
Part number
Teilenummer
Número de pieza

6

Número de decal
Decal number
Nummer von Abziehbild
Número de calcomanía

PEINTURES ESSENTIELLES / ESSENTIAL PAINTS

2 Vert brillant Gloss green Glänzend-Grün	11 Argent Silver Silber	22 Blanc brillant Gloss white Glänzend-Weiss	63 Sable mat Matt sand Matt-Sand	85 Noir satiné Satin black Seidenmatt-Schwarz	127 Gris satiné Satin grey Satin Grau

PEINTURES COMPLEMENTAIRES / ADDITIONAL PAINTS

14 Bleu brillant Gloss blue Glänzend-Blau	18 Orange brillant Gloss orange Glänzend-Orange	19 Rouge brillant Gloss red Glänzend-Rot	33 Noir mat Matt black Matt-Schwarz

PEINTURES COMPLEMENTAIRES / ADDITIONAL PAINTS

Disponibles séparément chez votre revendeur de maquettes. / Available separately at you local hobby shop.

41 Ivoire brillant Gloss ivory Glänzend-Elfenbein	53 Gris métallique Gunmetal Metallgrau	56 Aluminium Aluminium Aluminium	62 Cuir mat Matt leather Matt-Leder	66 Gris olive mat Matt olive drab Matt-Olivgrün	69 Jaune brillant Gloss yellow Glänzend-Gelb	71 Chêne satiné Satin oak Satin-Eichgrün	321 Rouge transparent Clear red Durchsichtiges Rot	322 Orange transparent Clear orange Durchsichtiges Orange

- Si aucune teinte n'est spécifiée, peindre dans les couleurs de la version choisie. Se reporter aux pages 19 à 23 pour le détail du schéma de peinture.
- When no color is specified, paint the item with colors of chosen version. Refer to pages 19 - 23 for painting pattern.
- Wenn keine Farbe angegeben ist, Teile mit den Farben der gewählten Version bemalen. Beachten Sie die Seiten 19 - 23 für die Lackierung und Markierung.
- Cuando ningún color es especificado, pintarle con los colores del tema de la versión elegida. Vea las páginas 19 - 23 para obtener detalles de pintura.

a • RENAULT 4 GTL, 1984



b • RENAULT 4 TL, 1984



c • RENAULT 4 TL Gendarmerie, 1984



d • RENAULT 4 GTL Sapeurs Pompiers, 1984



e • RENAULT 4 GTL Equipement, 1984

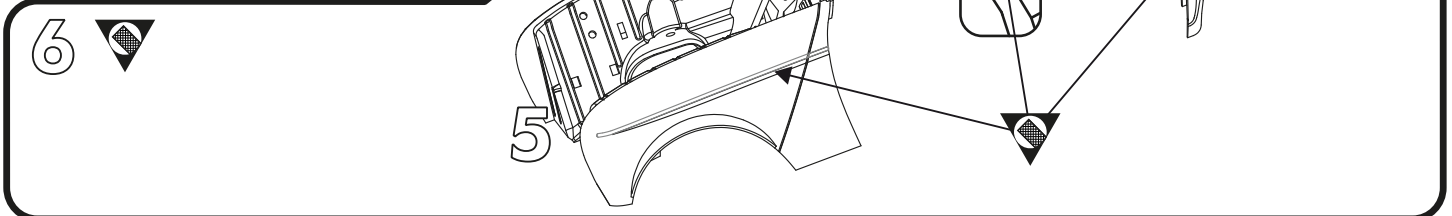
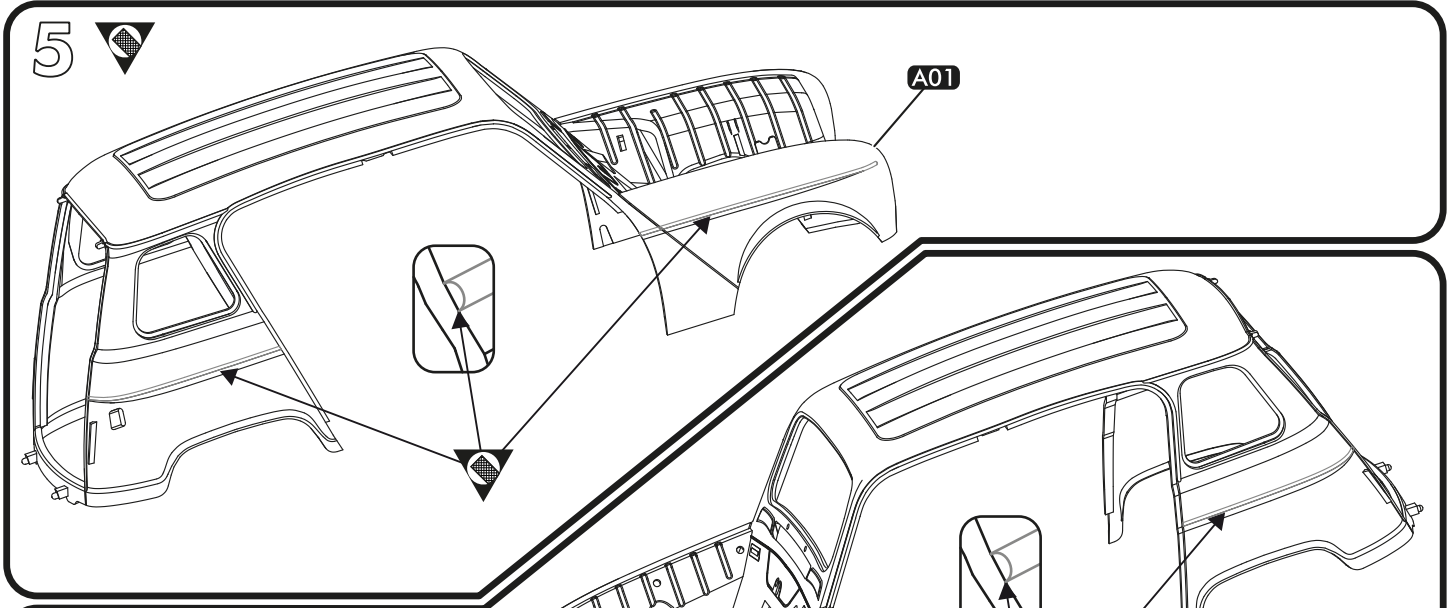
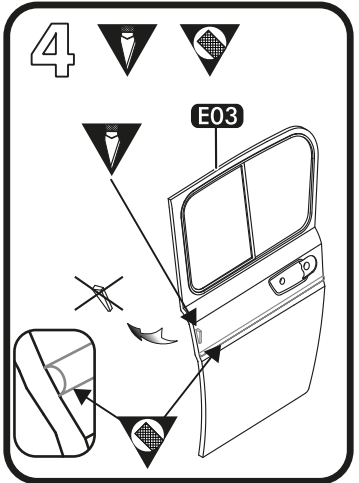
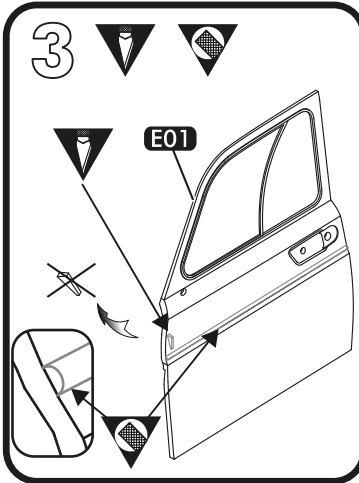
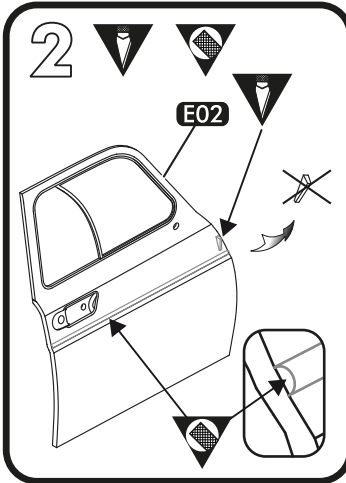
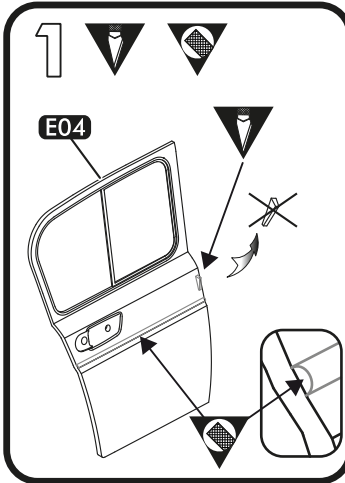

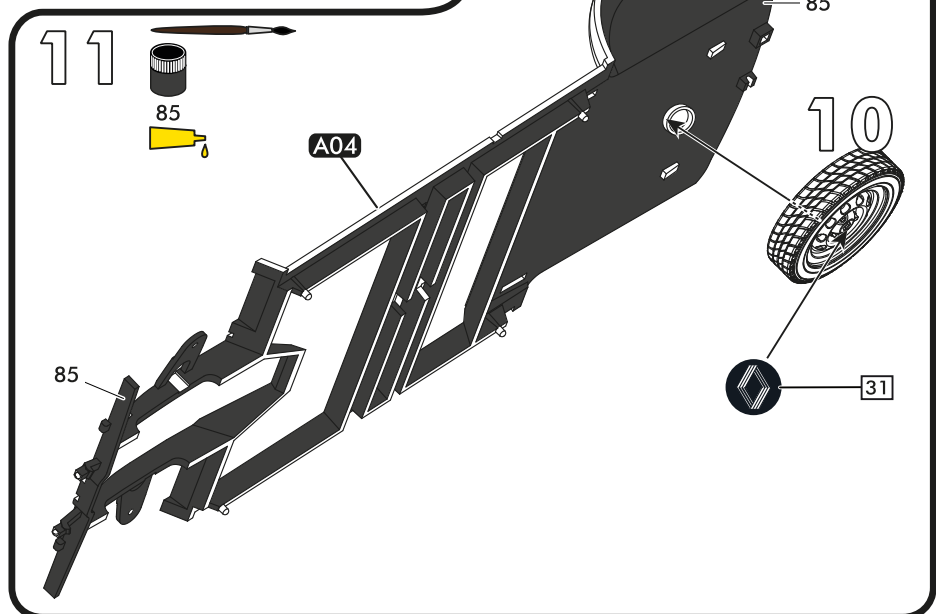
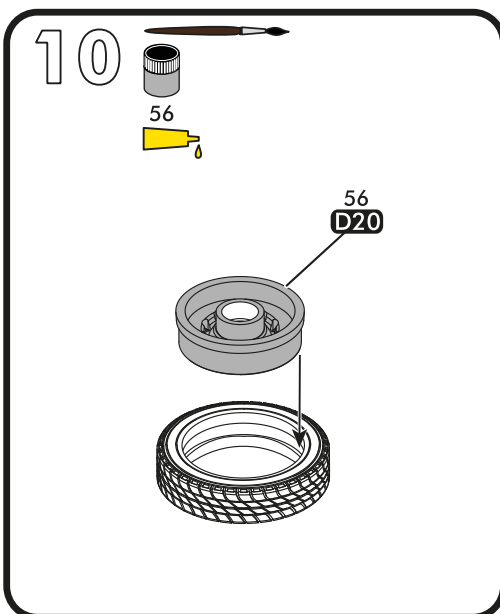
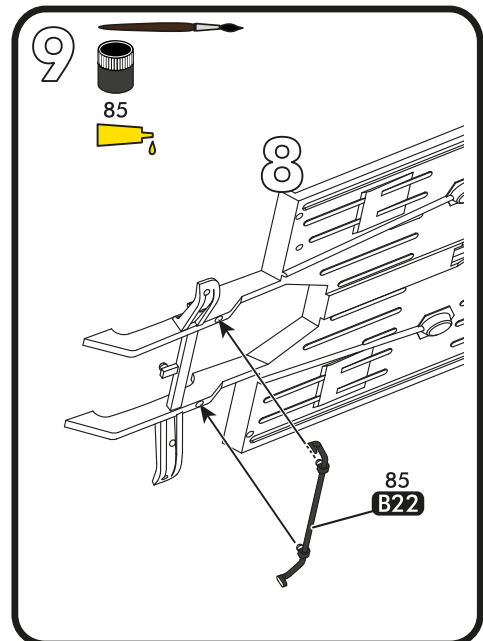
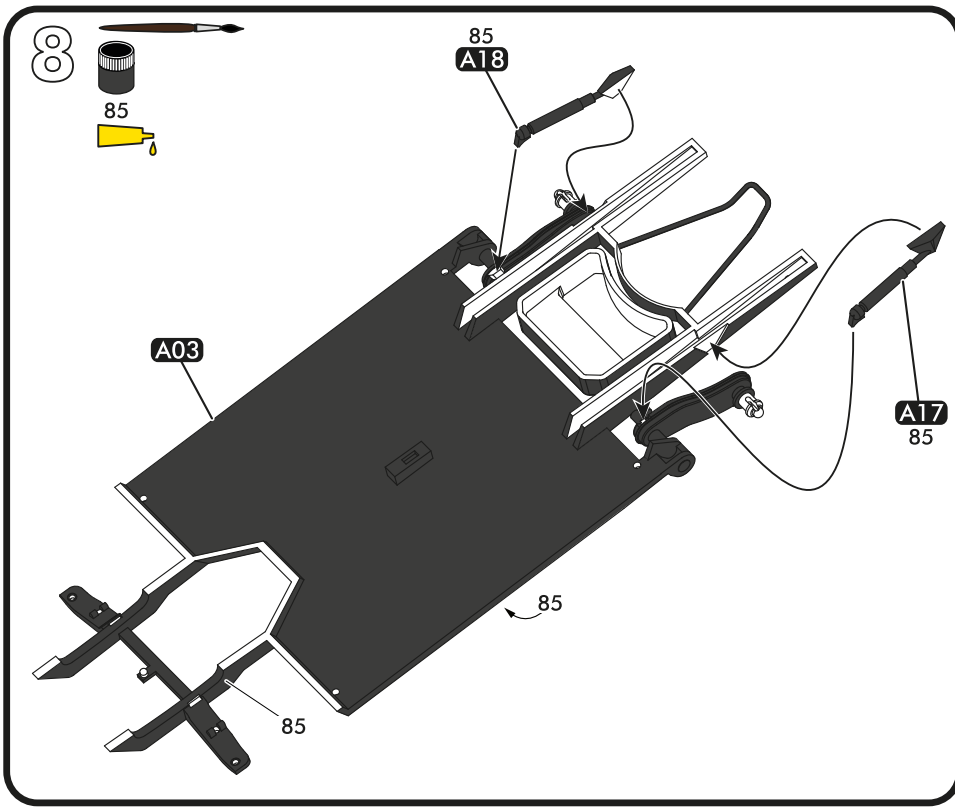
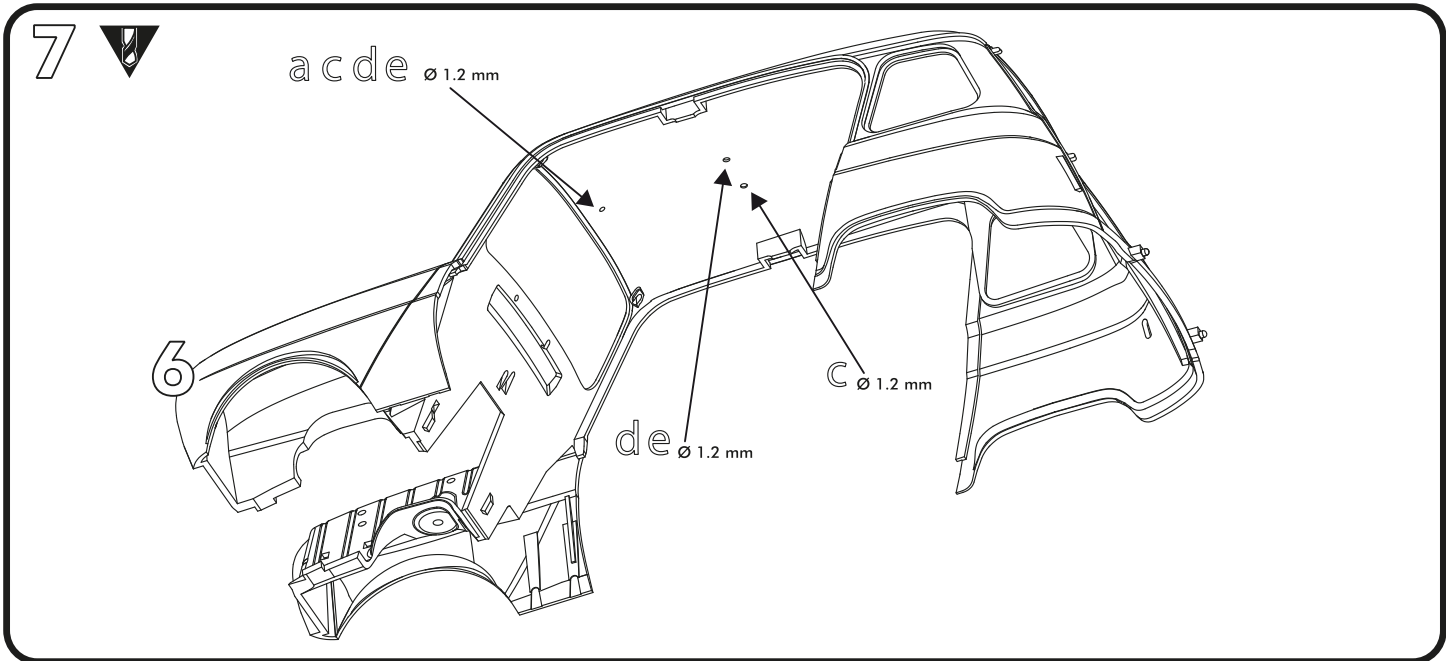

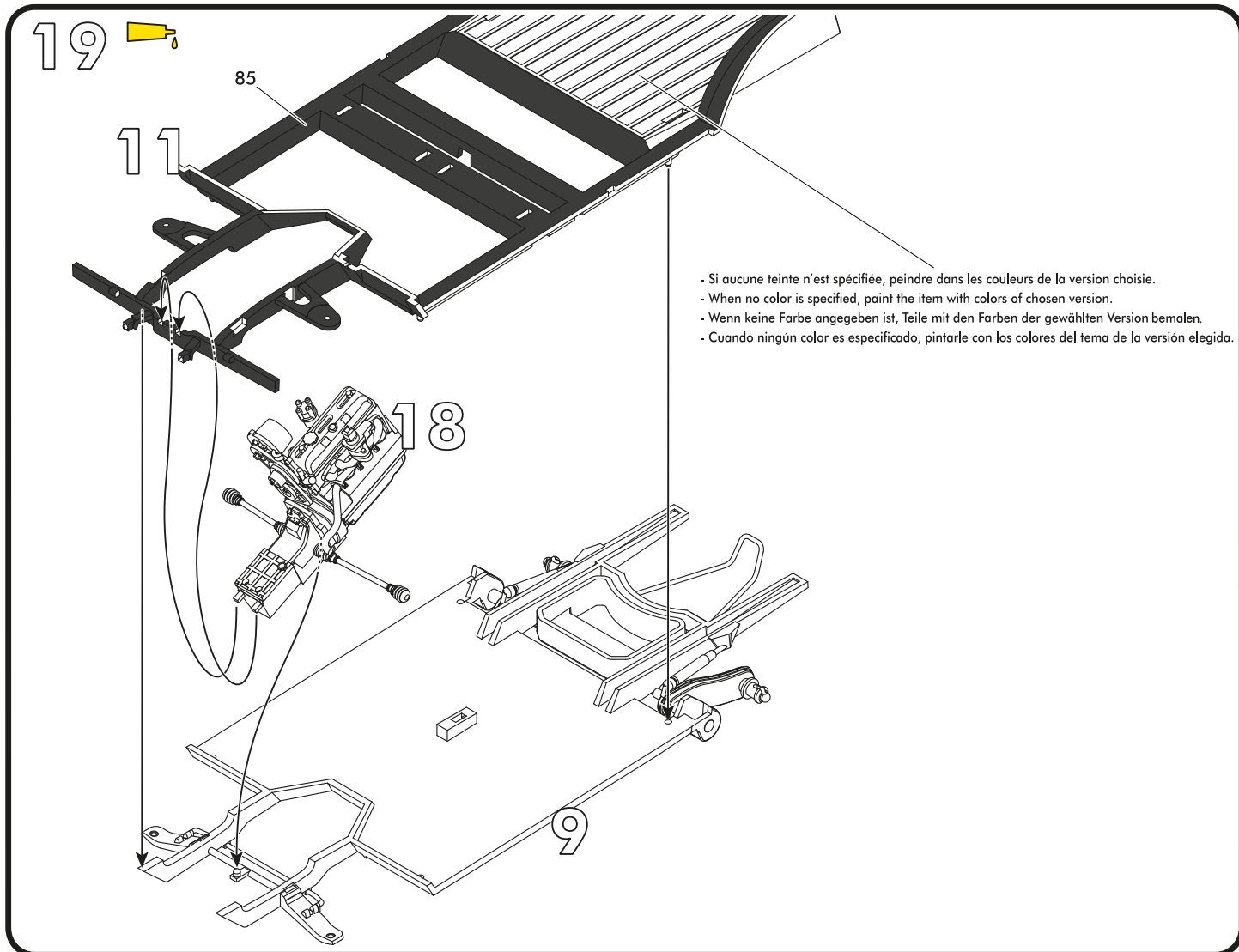
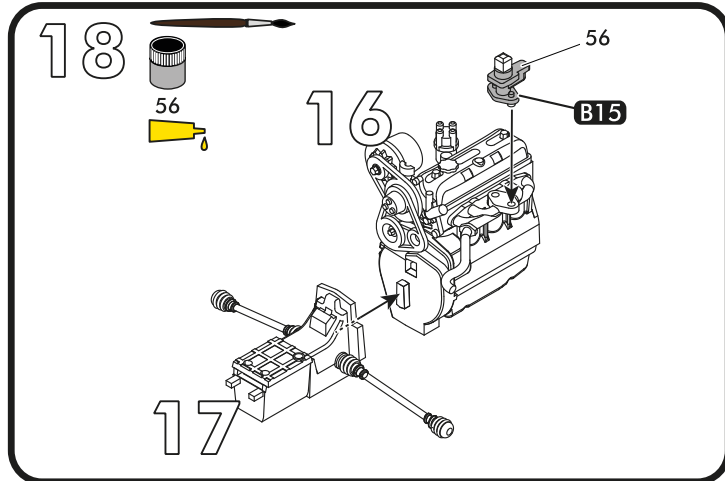
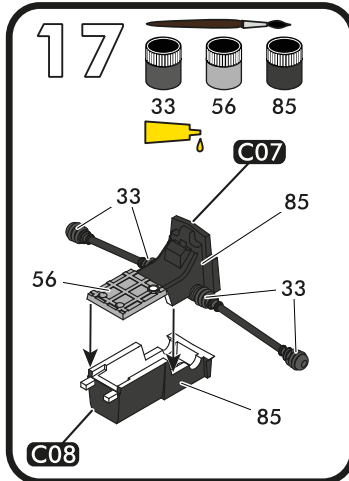
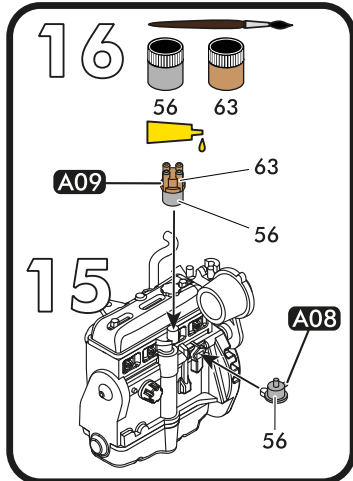
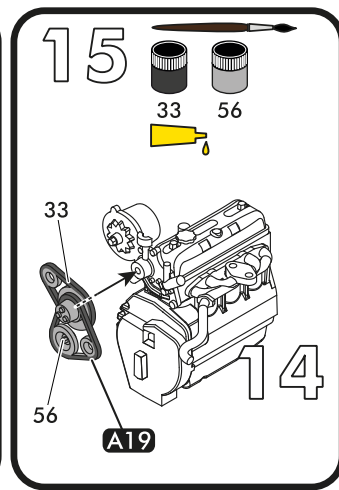
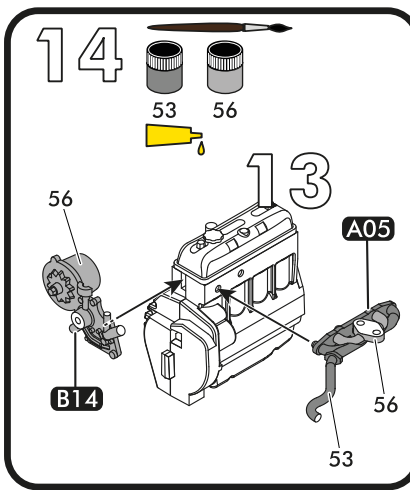
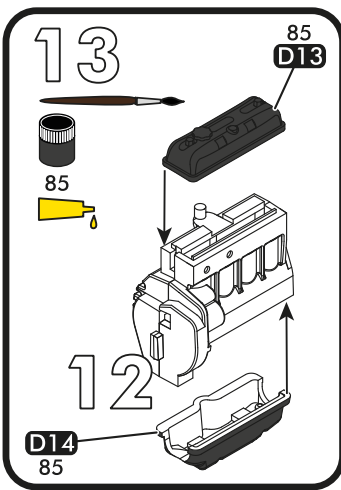
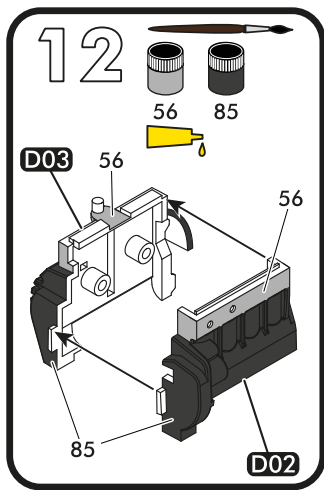

20

85

A → B

Côté droit
Right hand
Rechte Seite
Lado derecho

Avant
Front
Vorderteil
Delantera

19

A11 85

B11 85

21

85

A → B

Côté gauche
Left hand
Linke Seite
Lado izquierdo

20

Avant
Front
Vorderteil
Delantera

A11 85

B10 85

22

33 85

21

A20

33

85

23

56 x2

A21 56

D20 56

24

56 x2

A21 56

D20 56

25

a 63 ↔ ? b 62 ↔ ? cde 66

a 63 ↔ ? b 62 ↔ ? cde 66

a 63 ↔ ? b 62 ↔ ? cde 66

C02 ? b 62 ? cde 66

C03 ? b 62 ? cde 66

62 63 66

x2

26

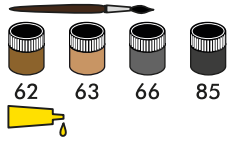

a 63 \longleftrightarrow b 62 \longleftrightarrow cde 66

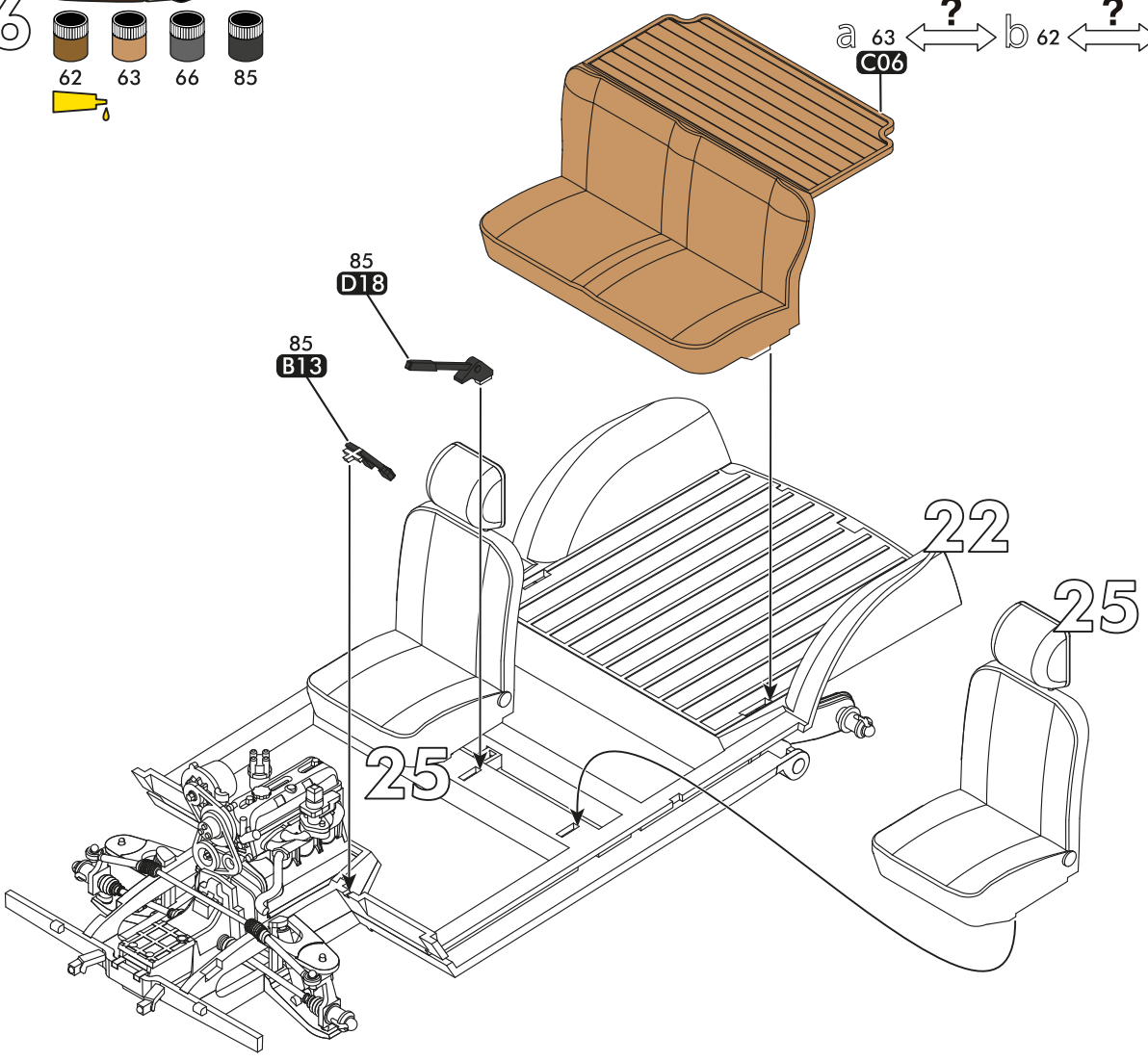

27

 Endiqueter
Snap fit
Schnappsitz
Engastar

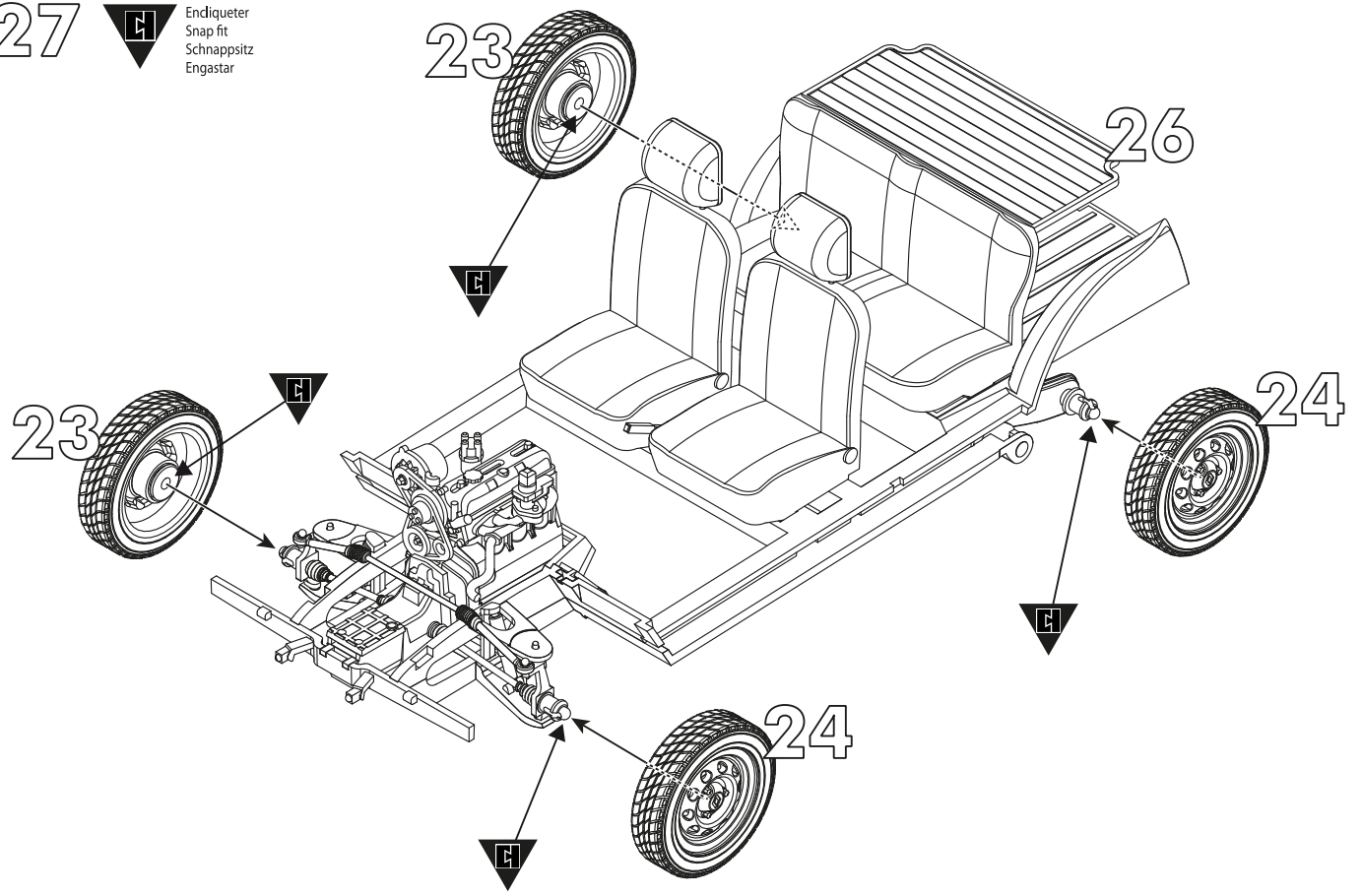

28

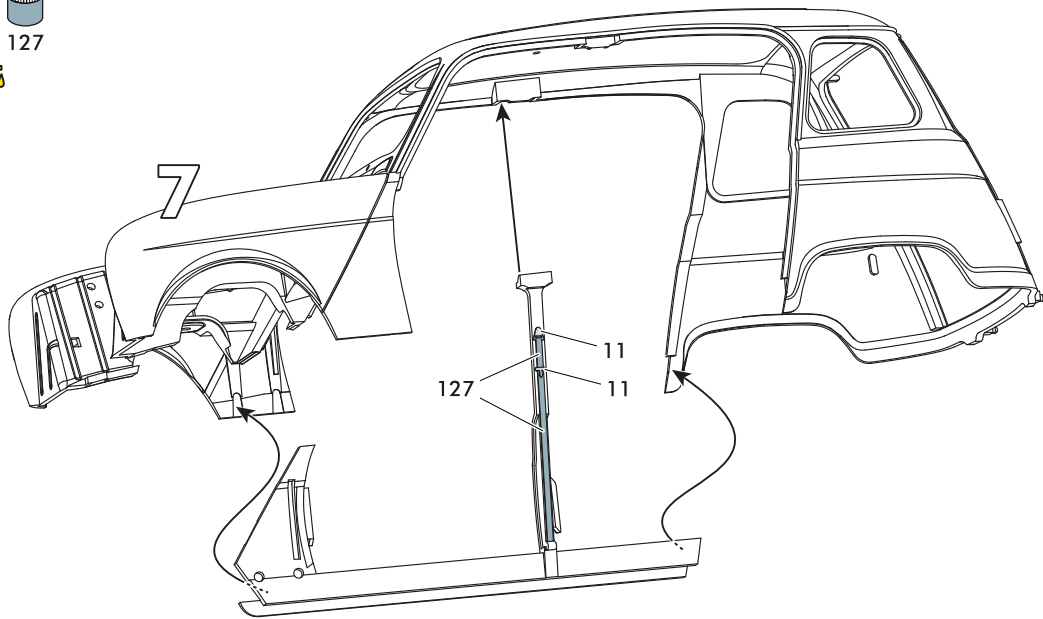
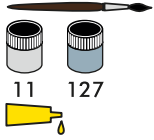

29

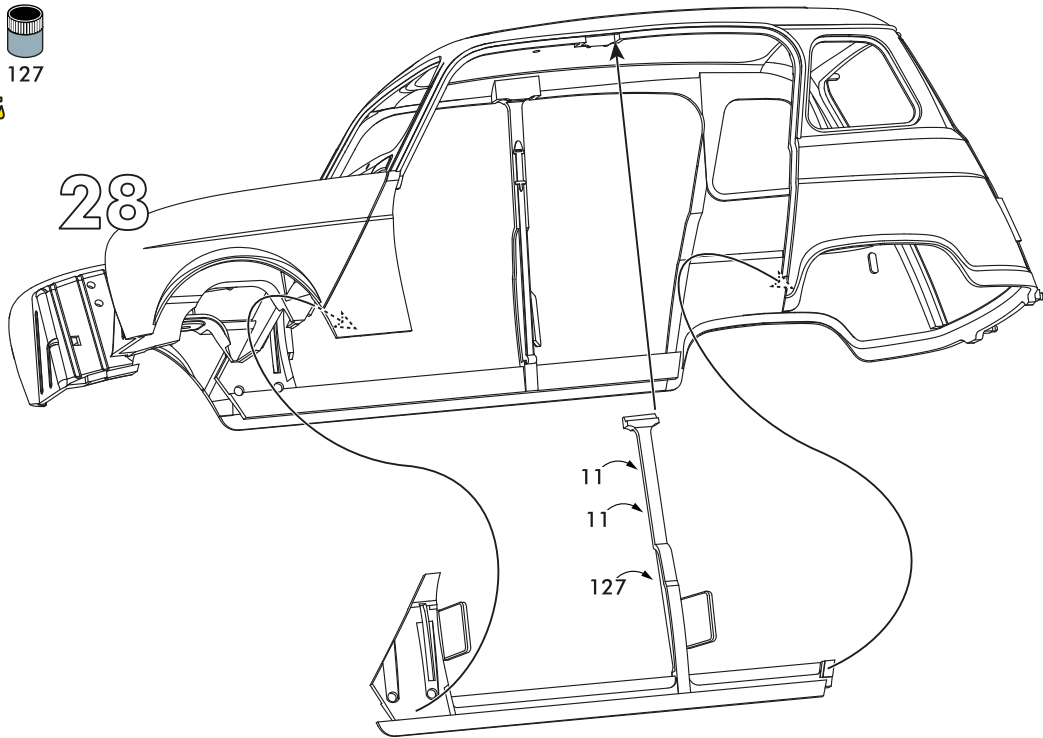
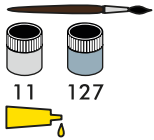

30

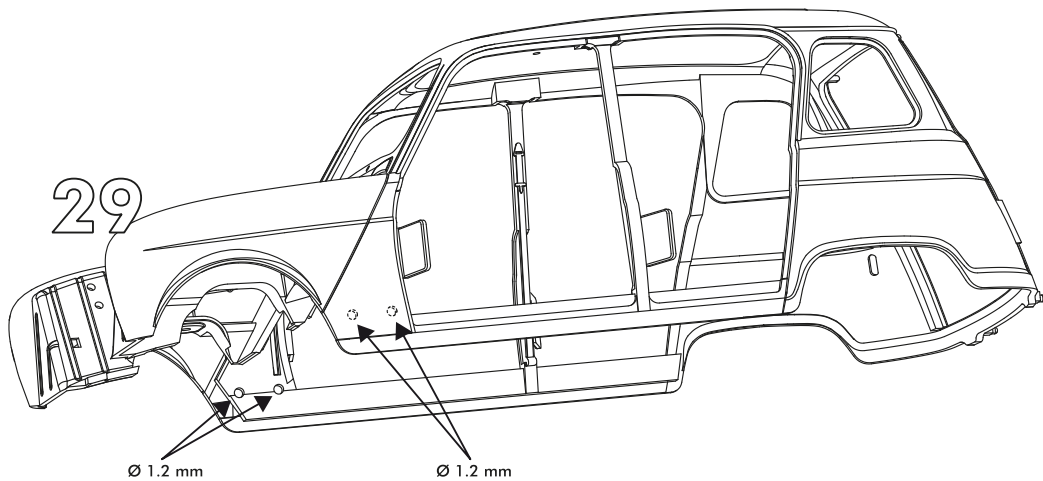

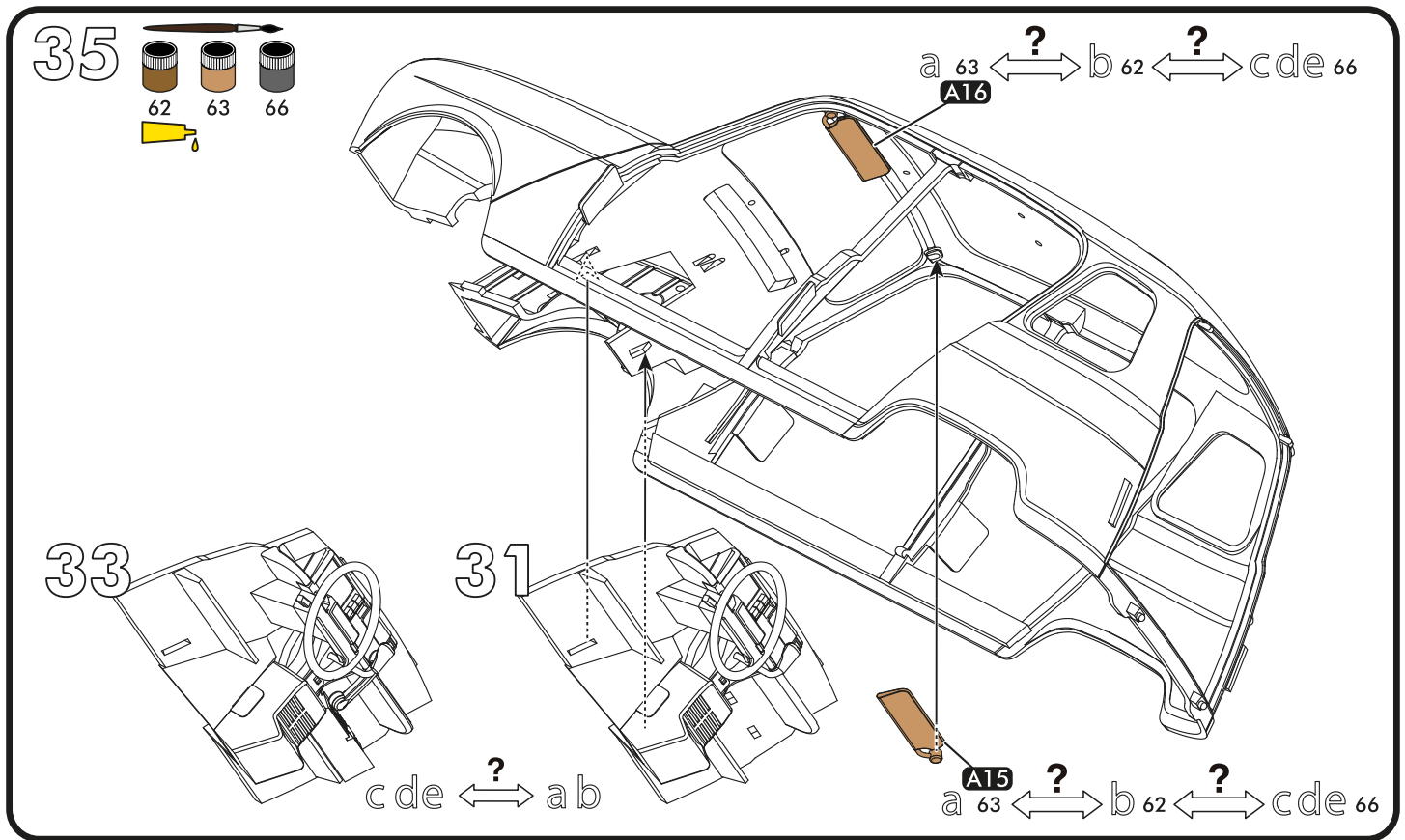
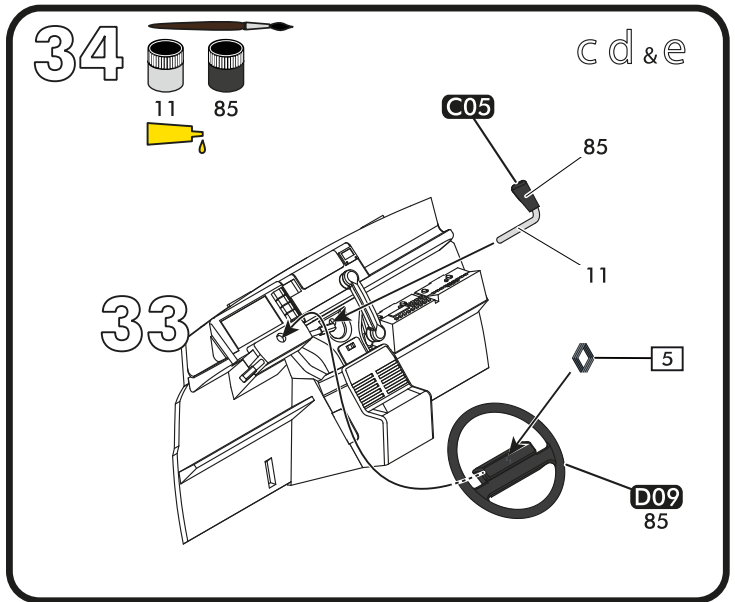
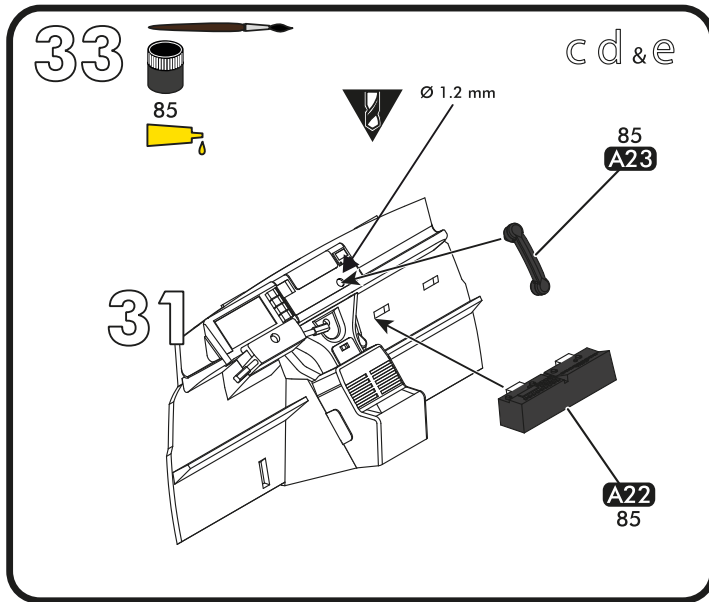
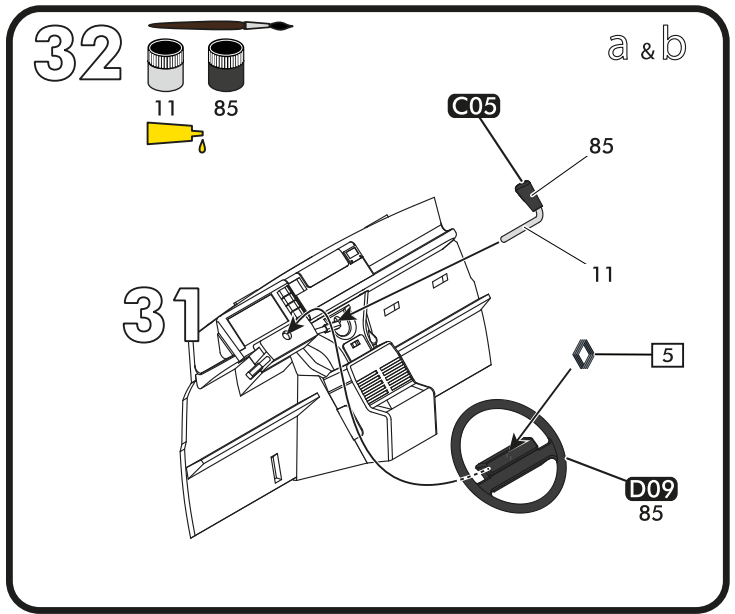
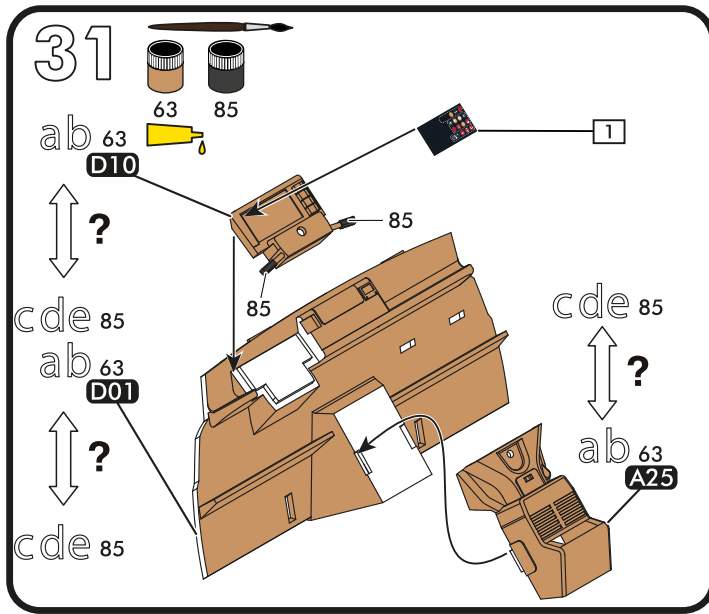

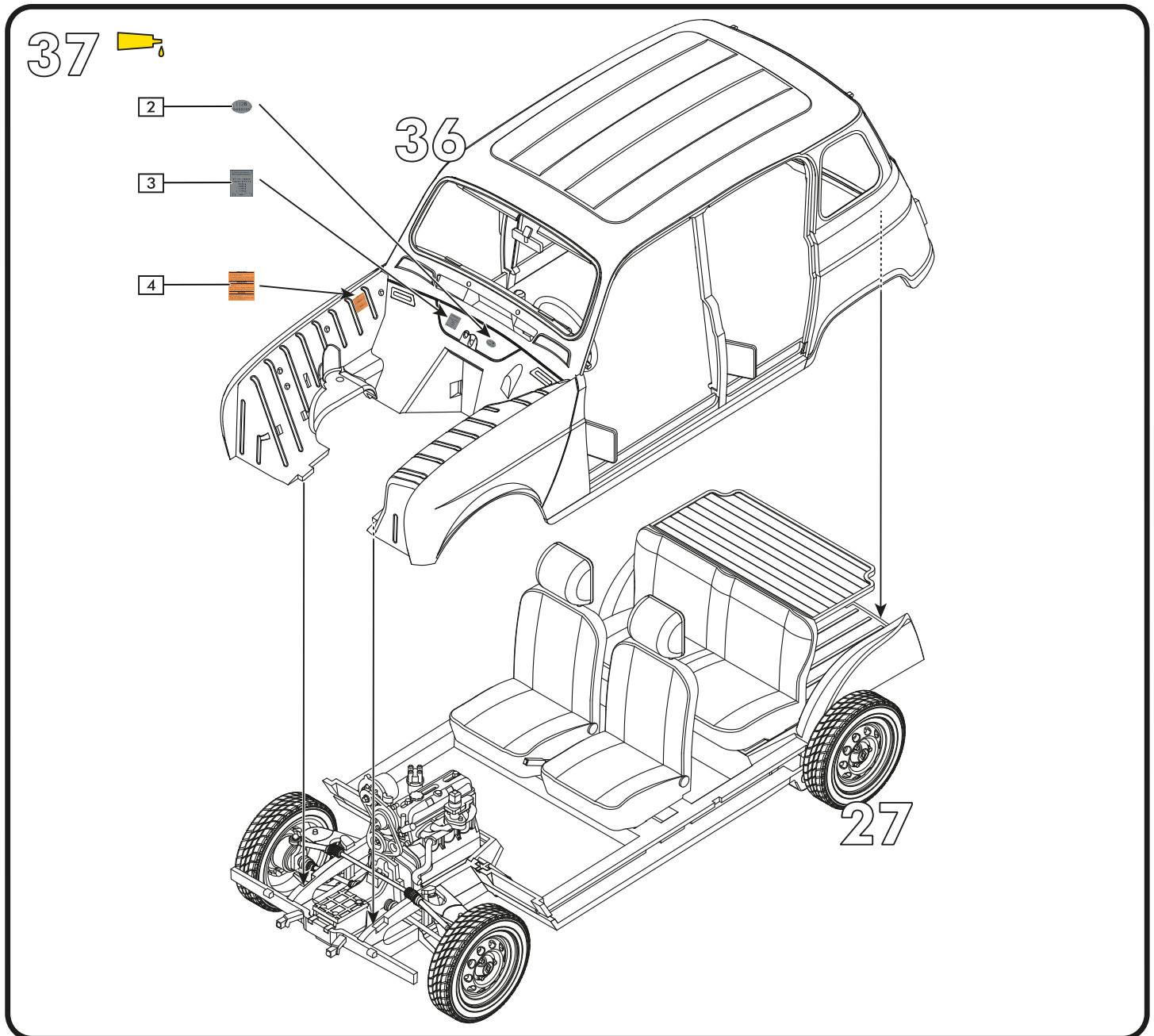
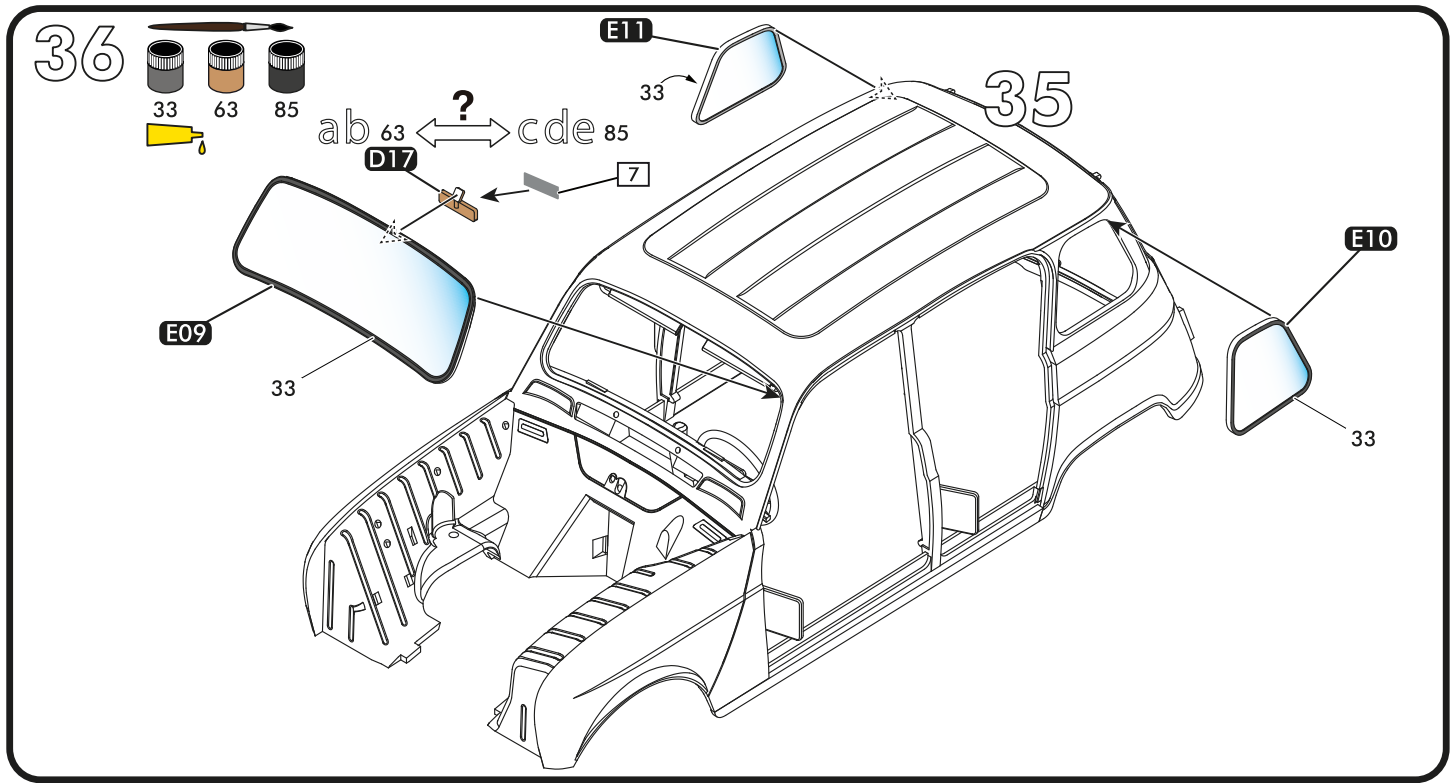

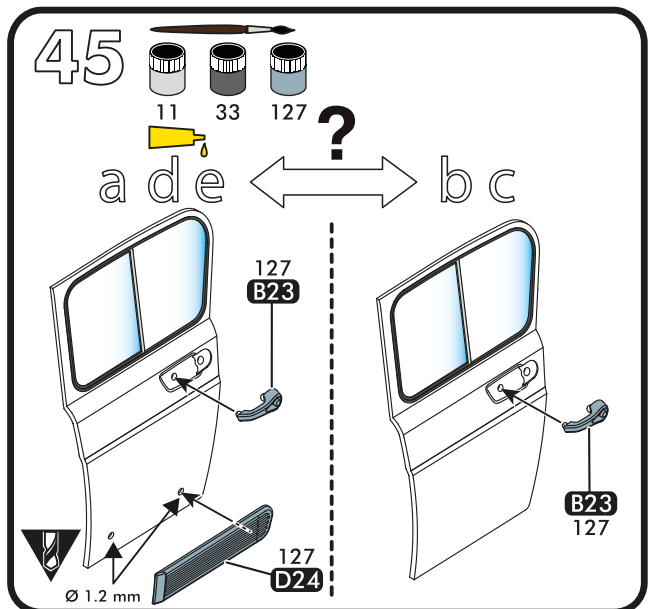
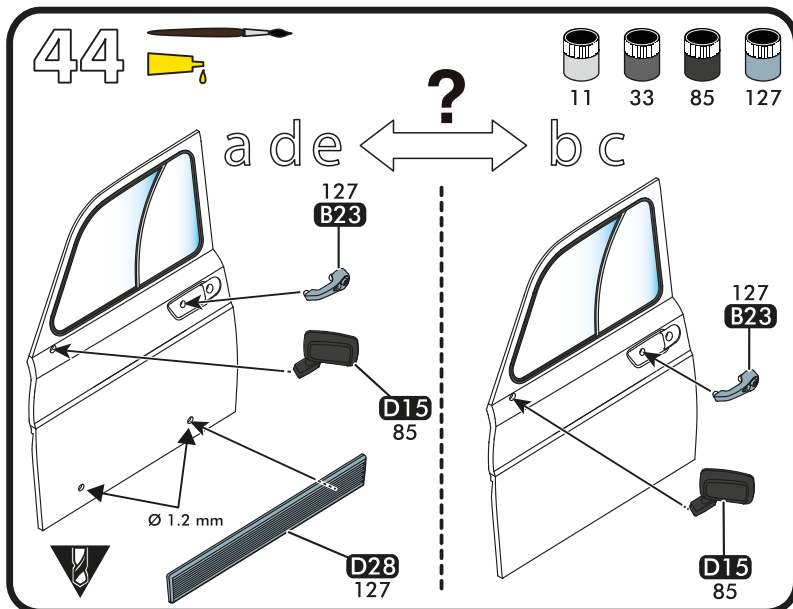
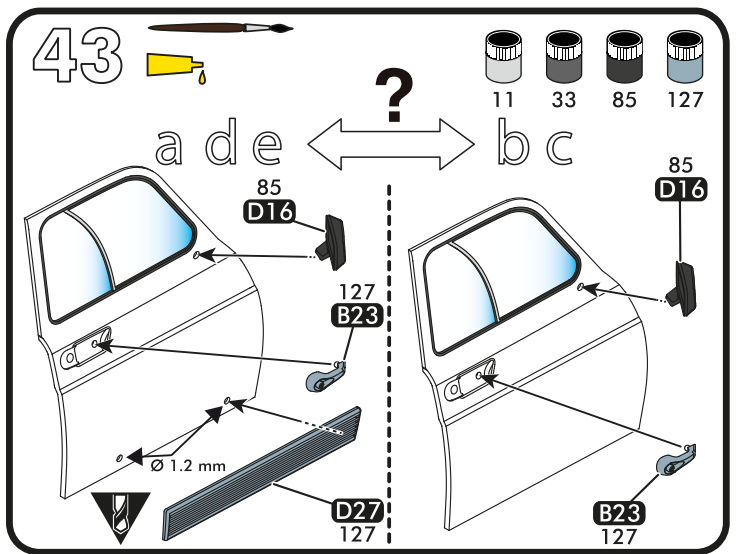
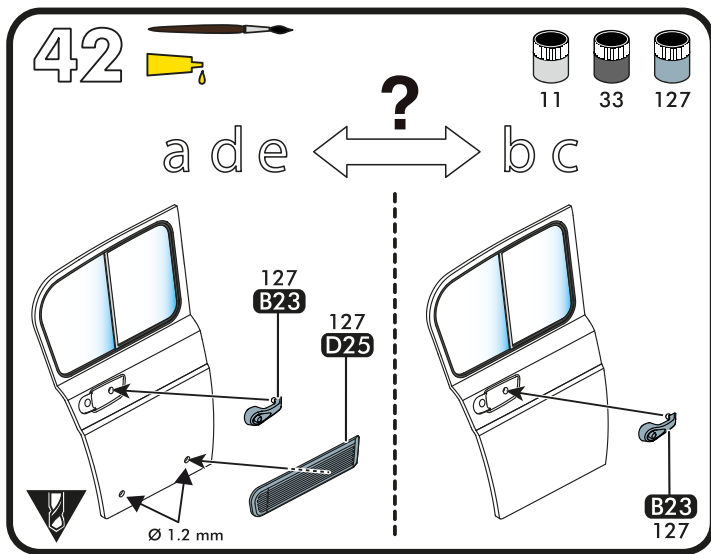
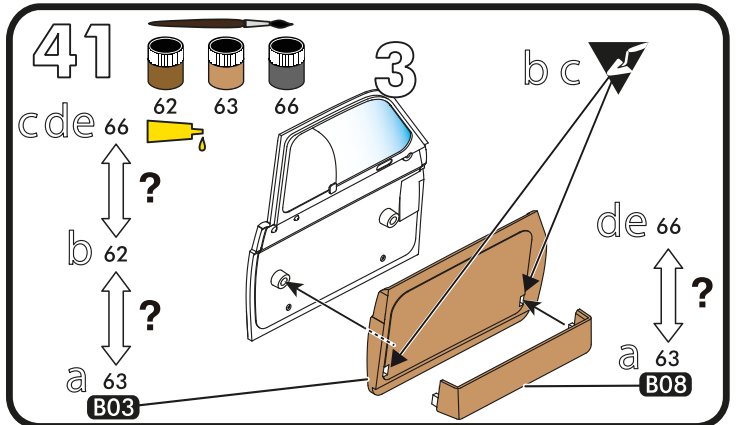
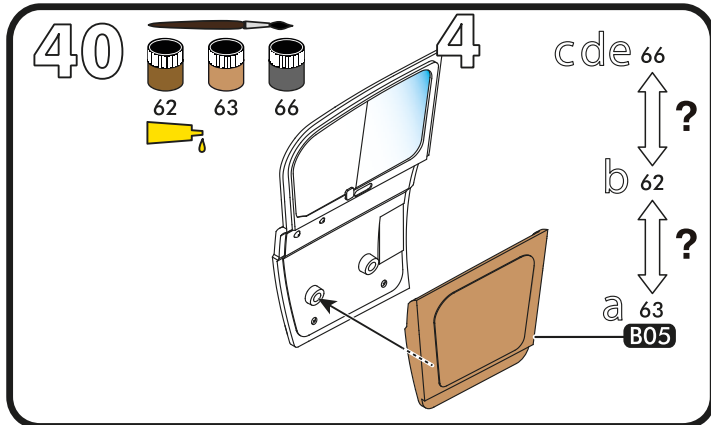
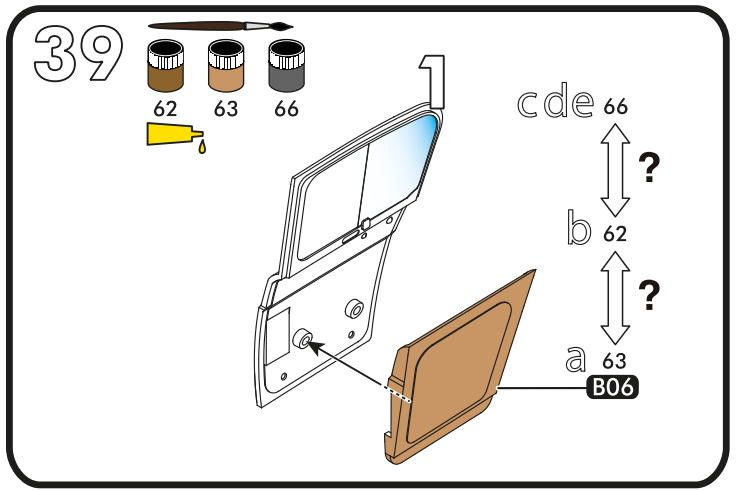
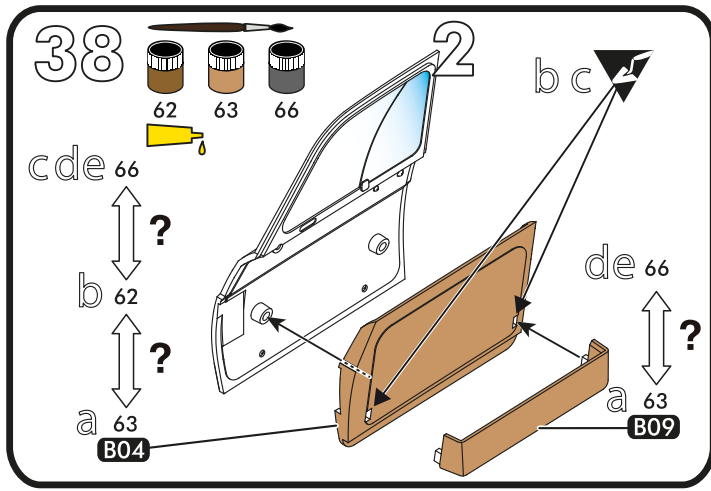

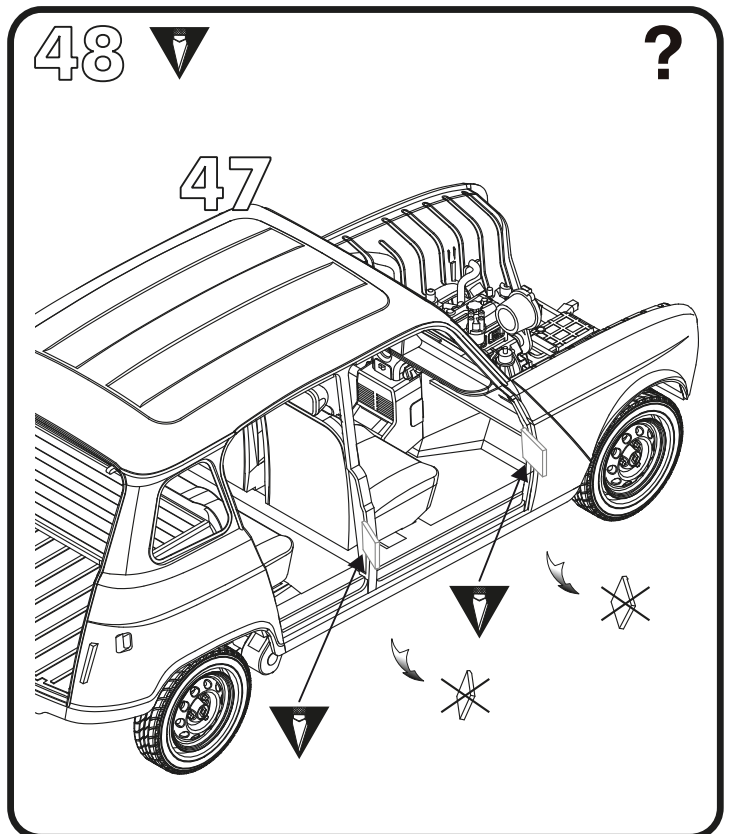
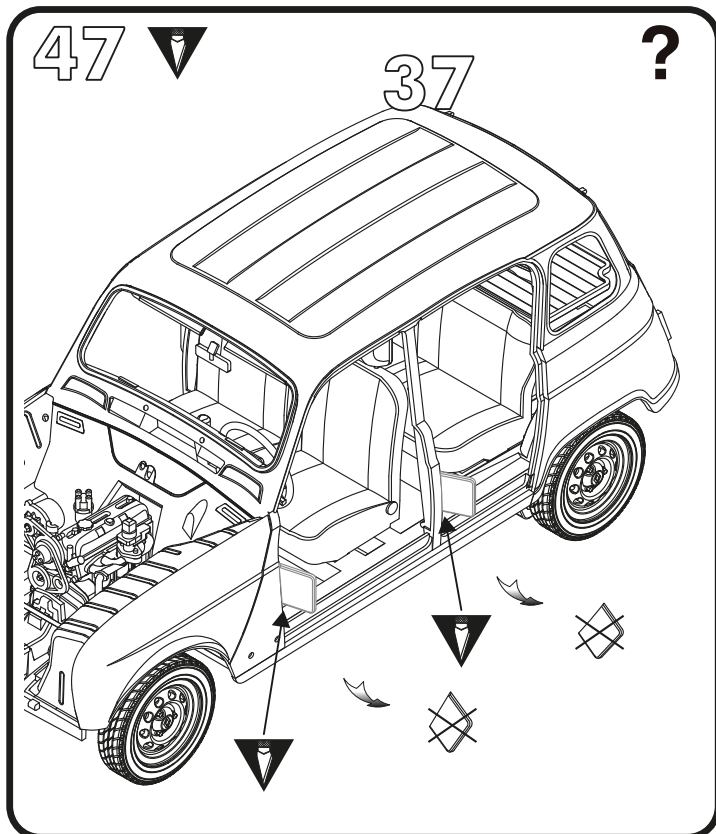
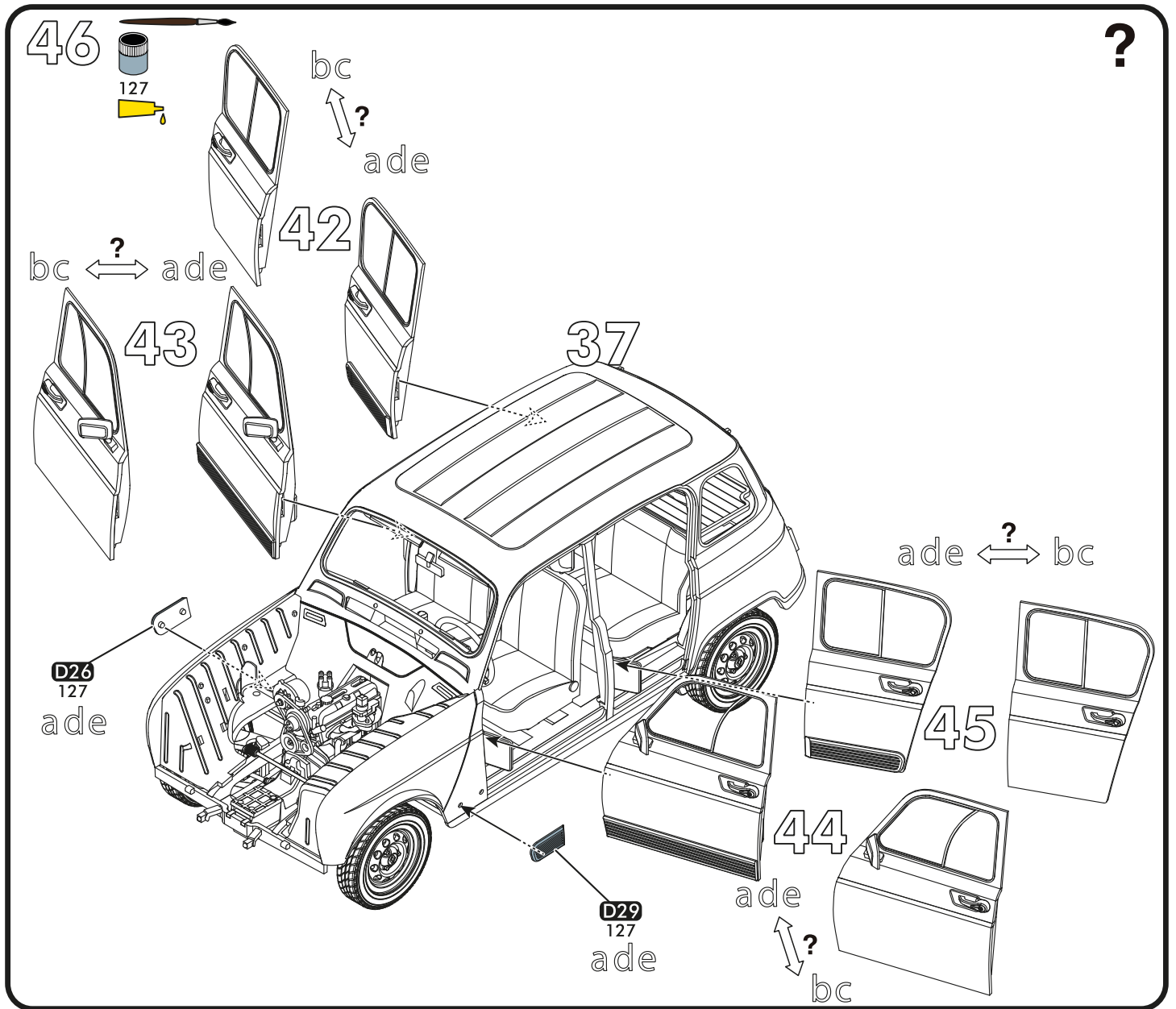

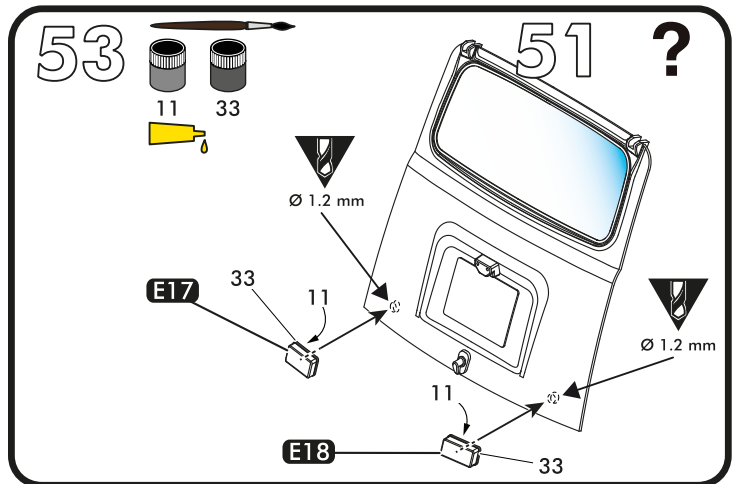
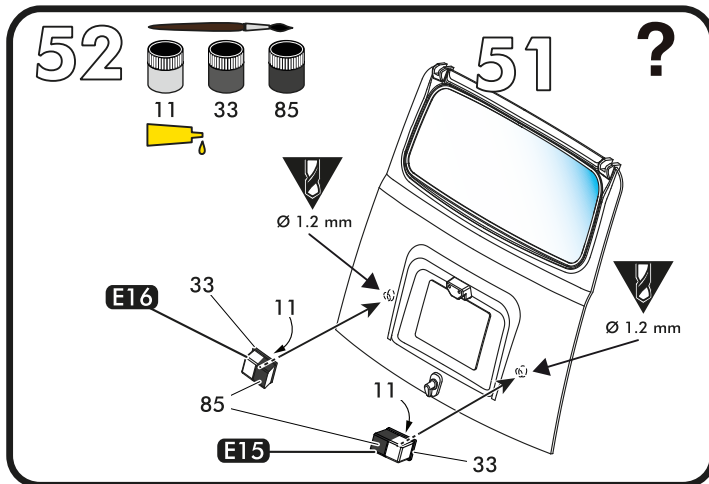
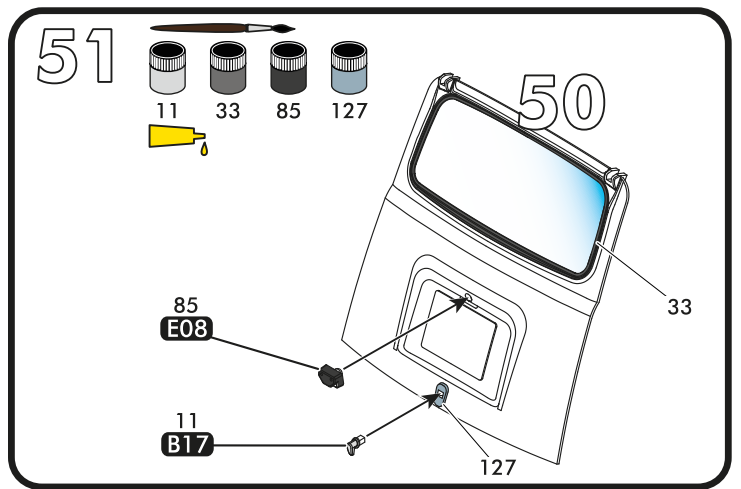
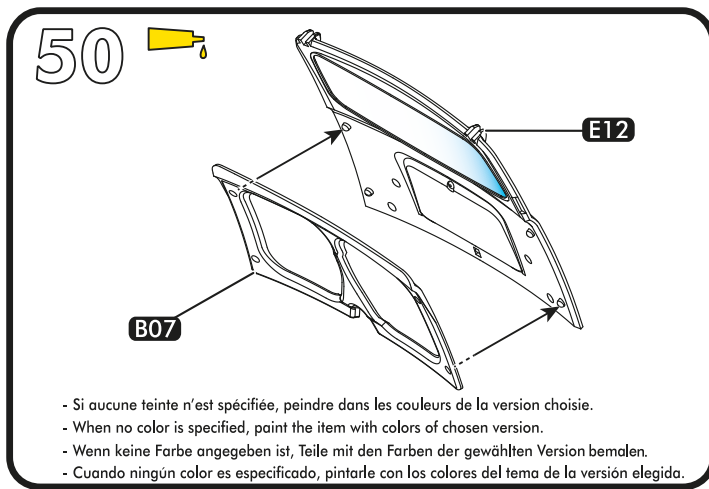
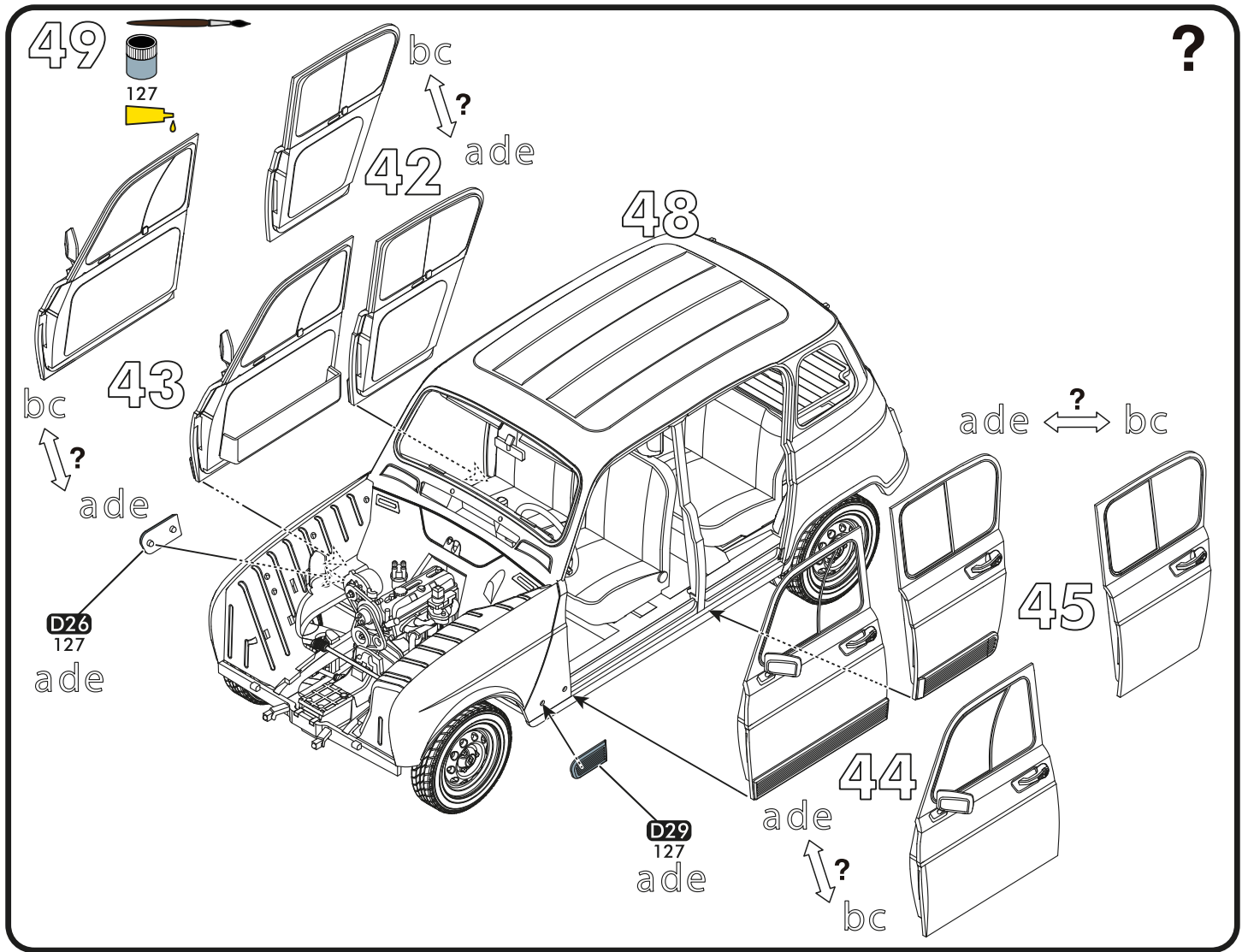

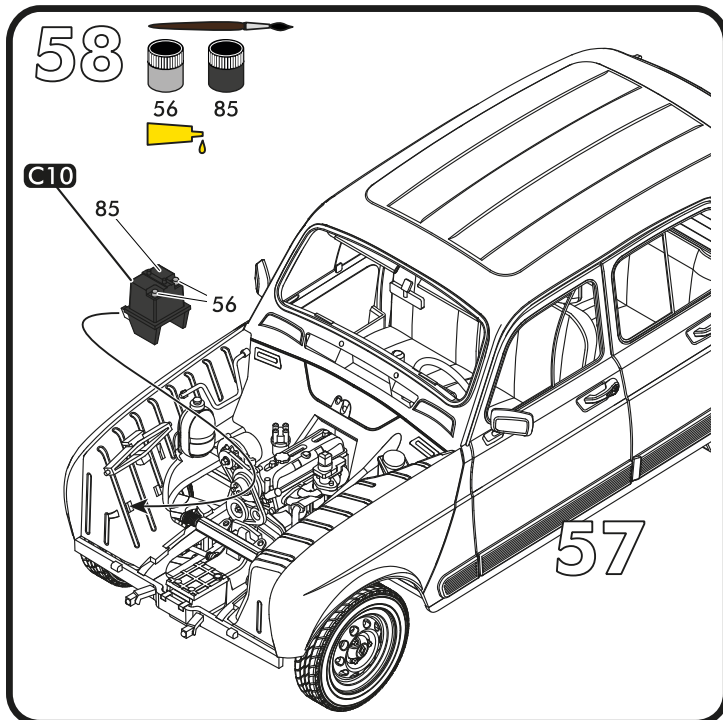
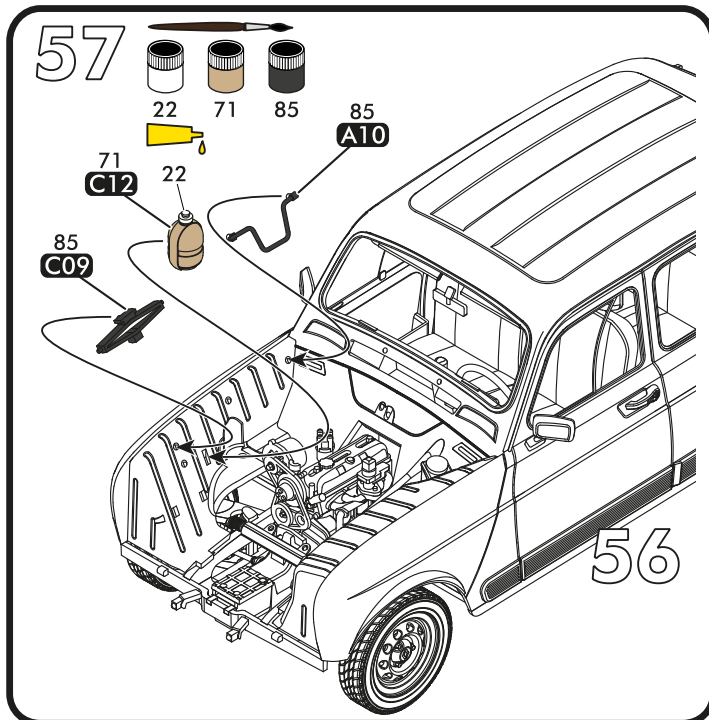
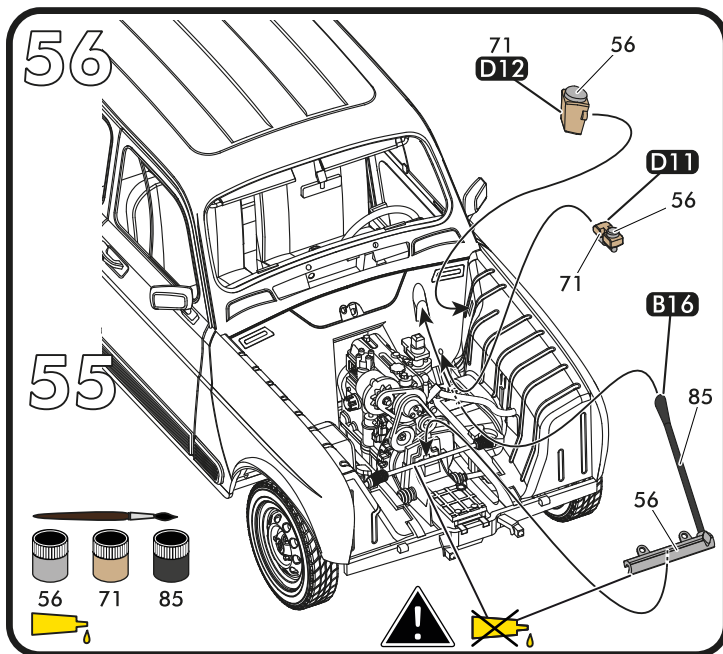
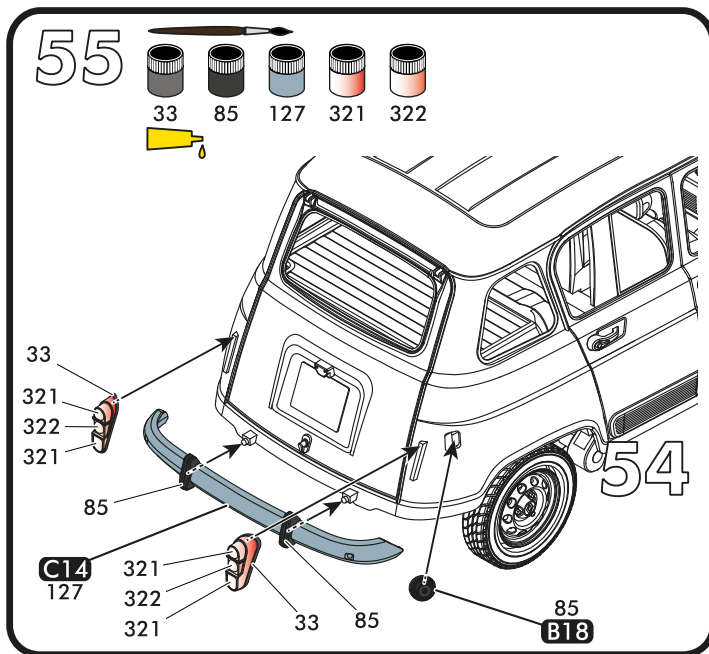
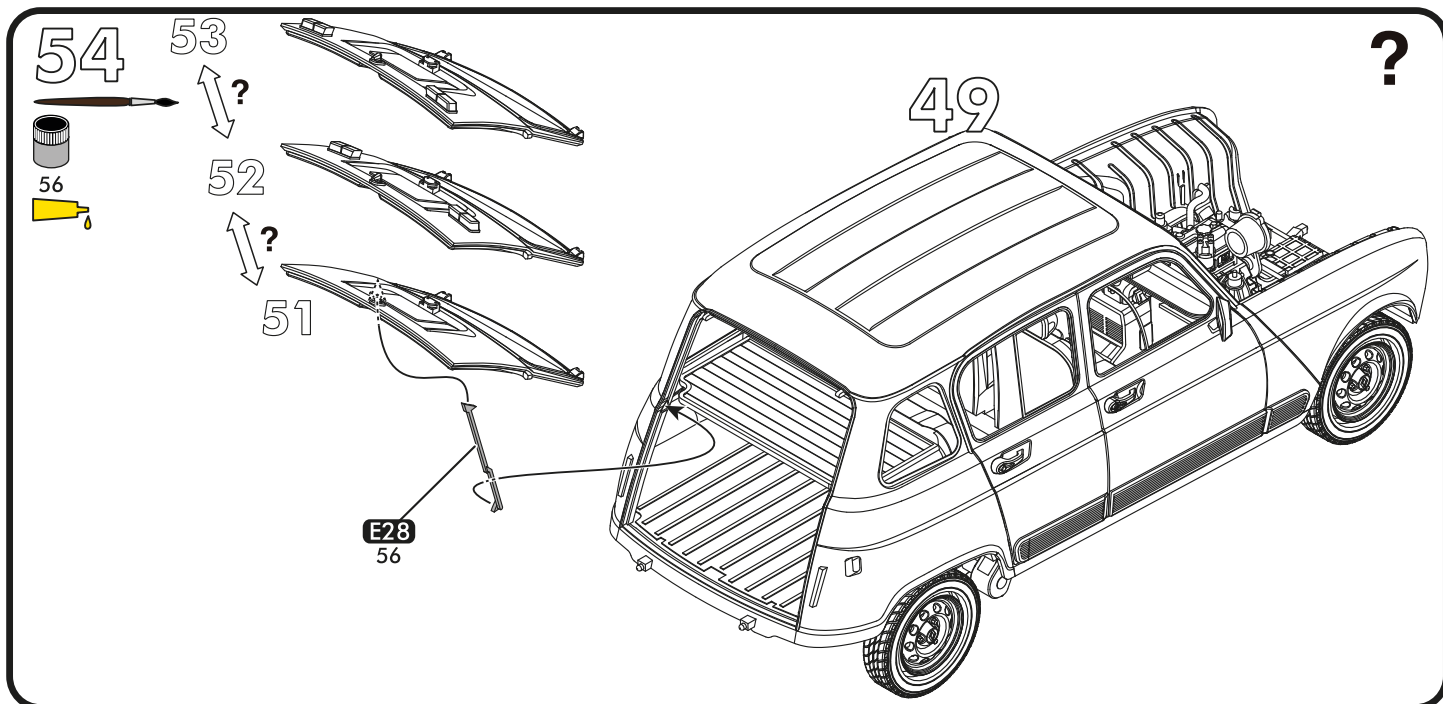

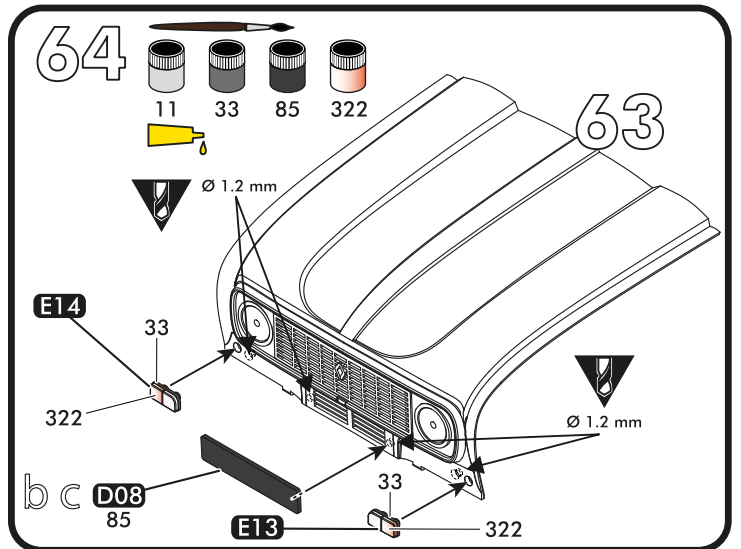
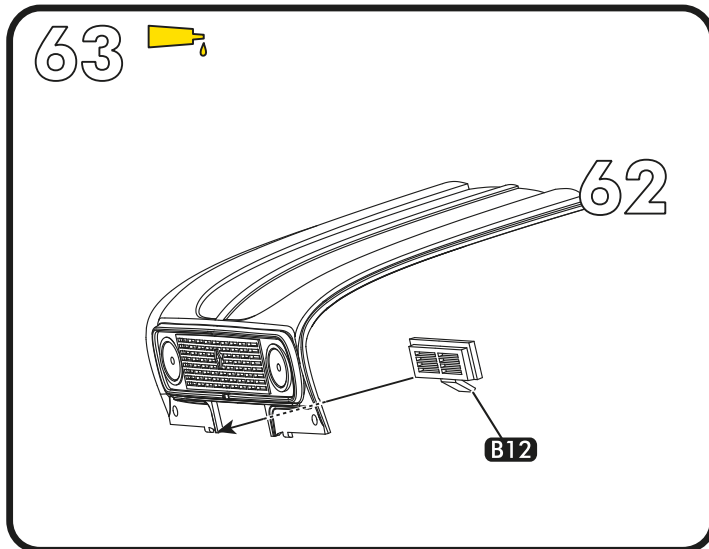
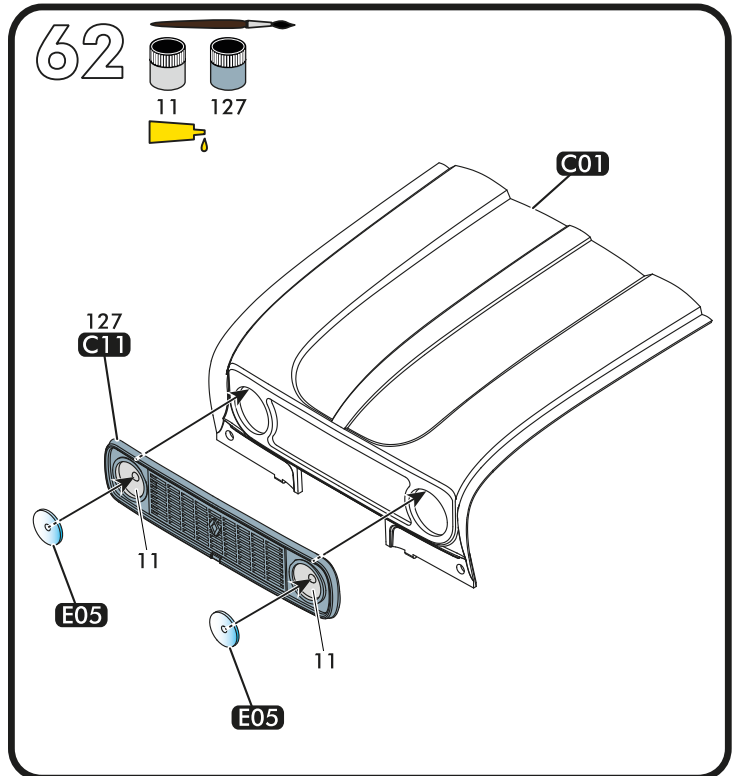
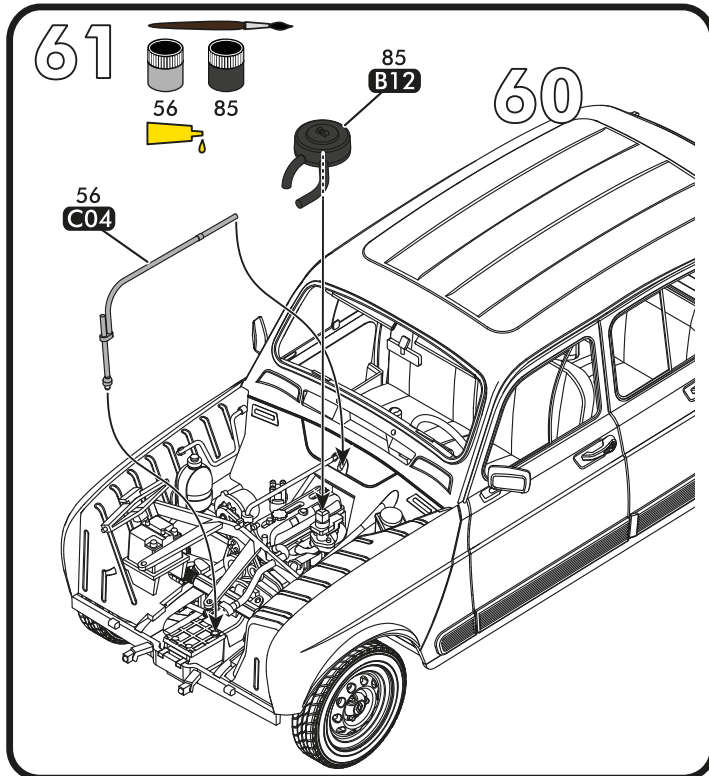
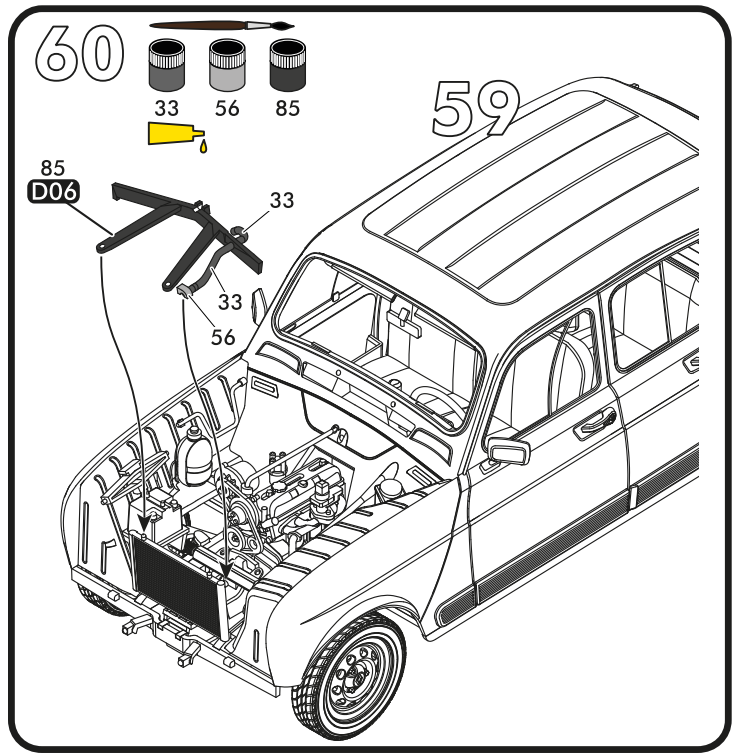
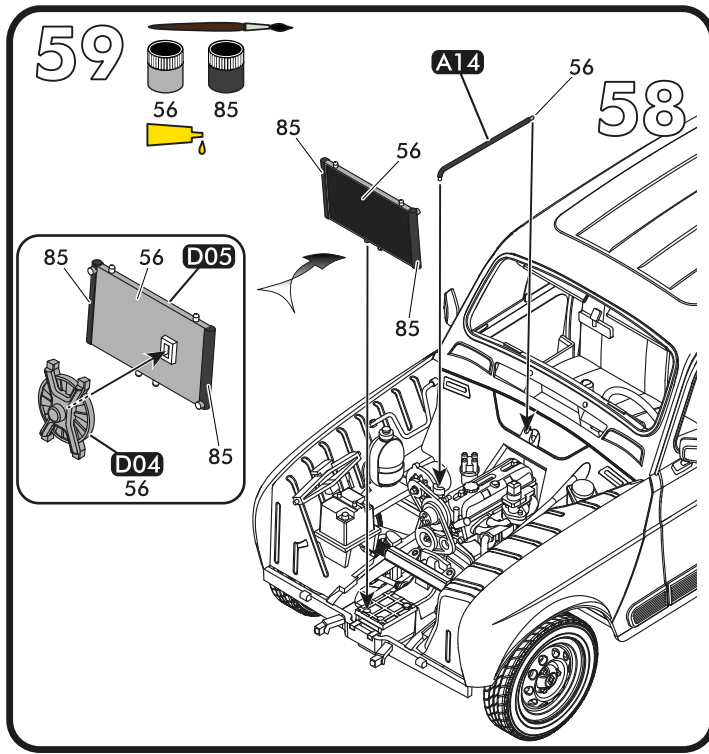

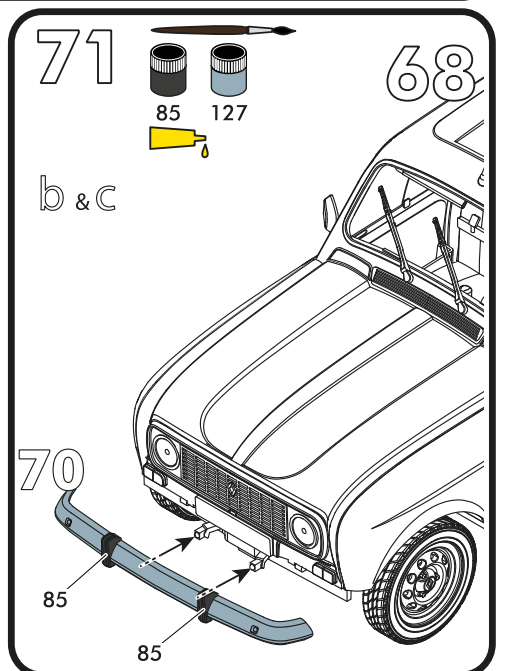
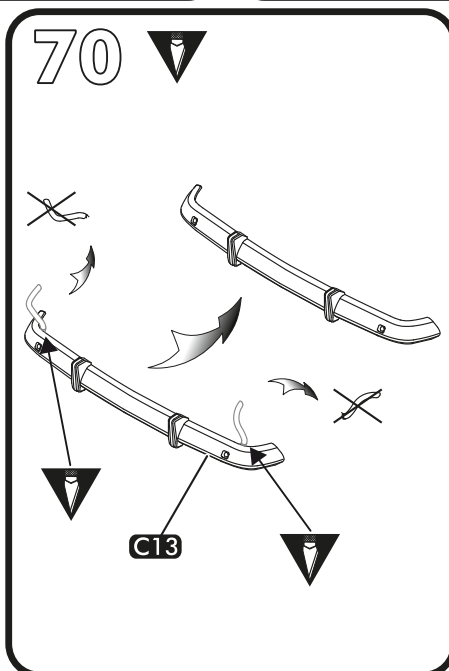
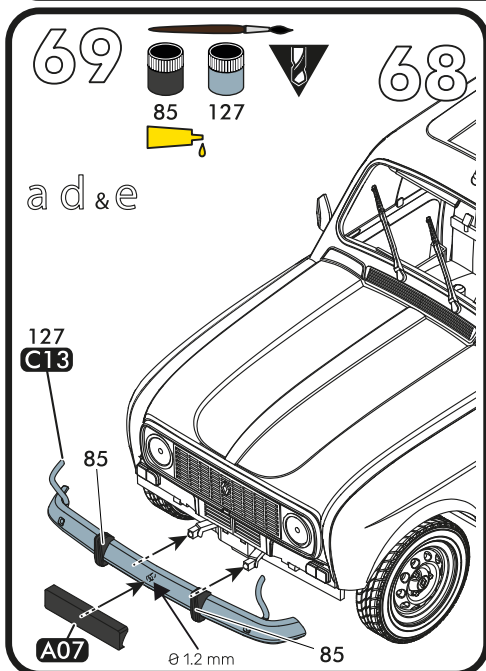
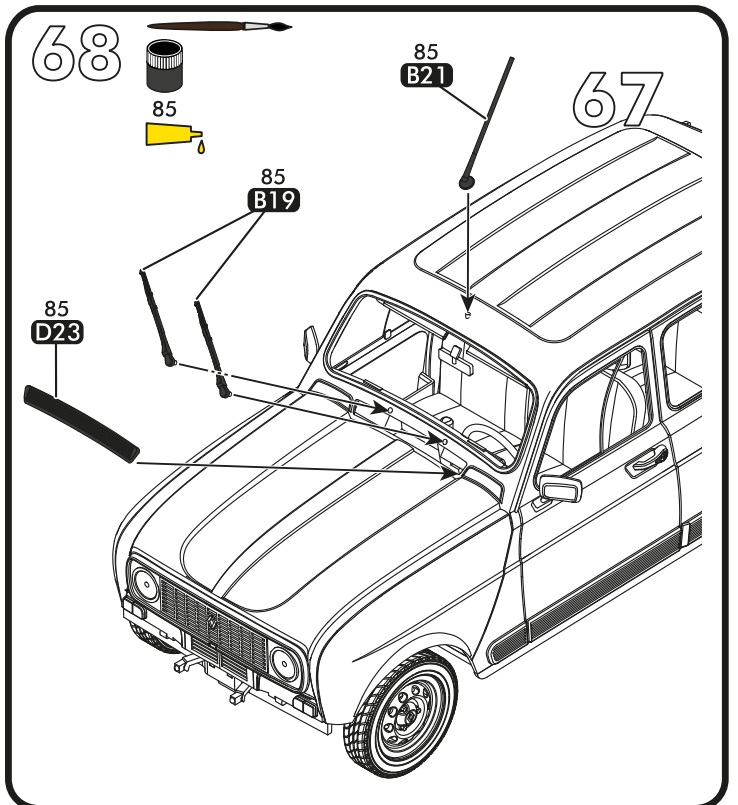
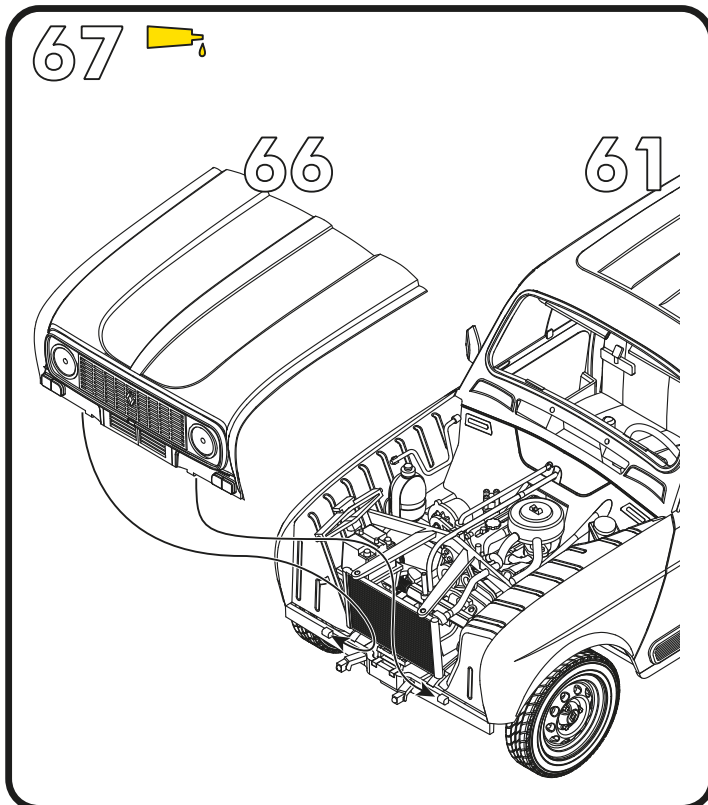
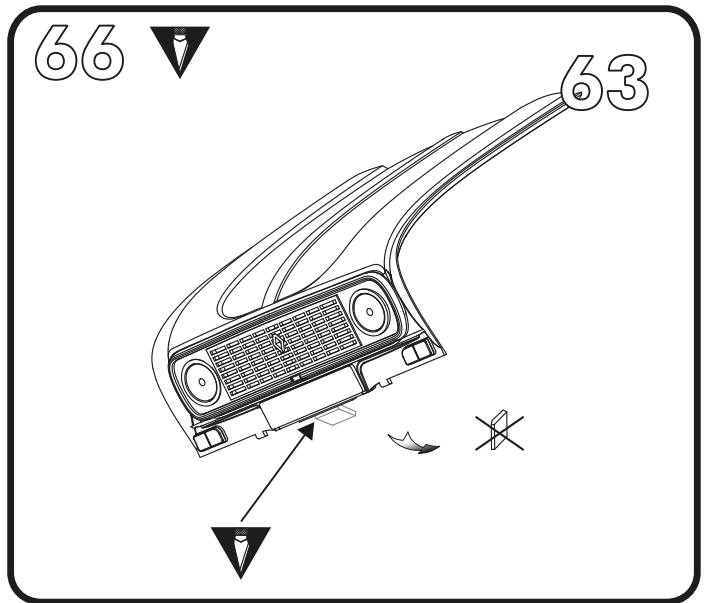
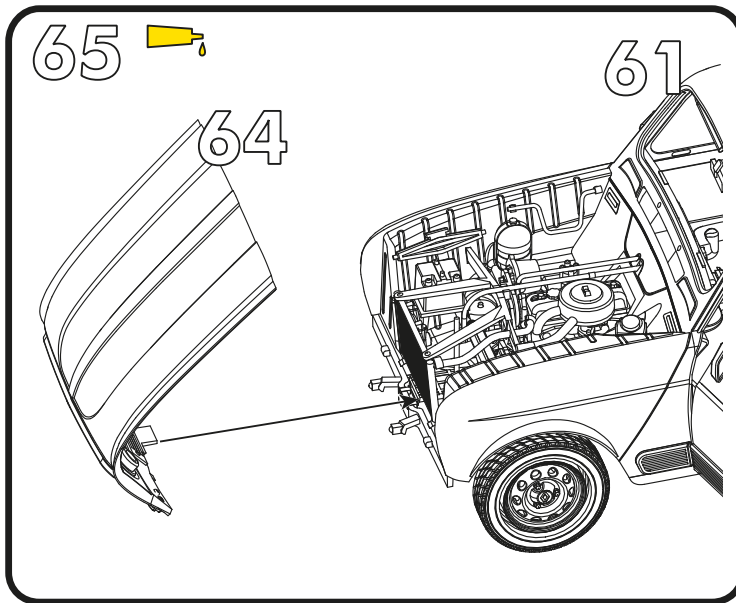

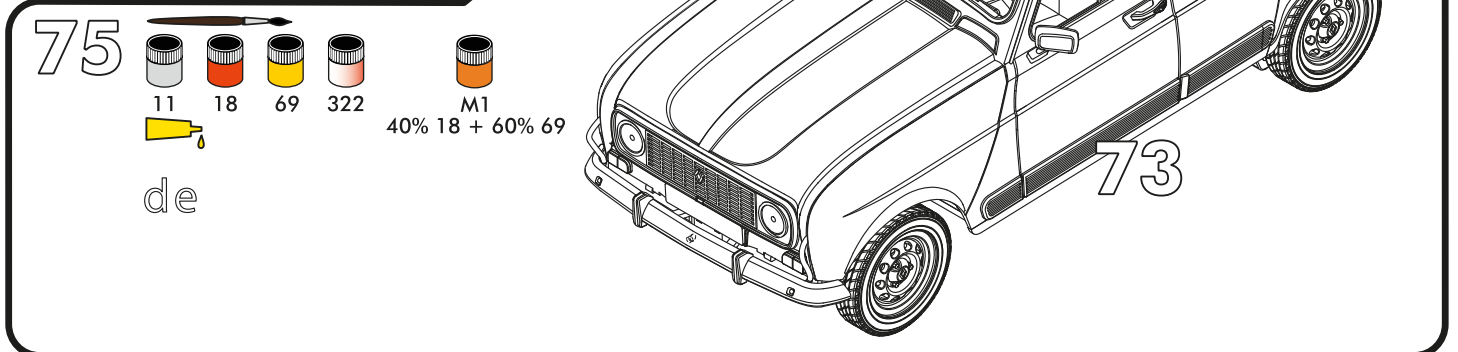
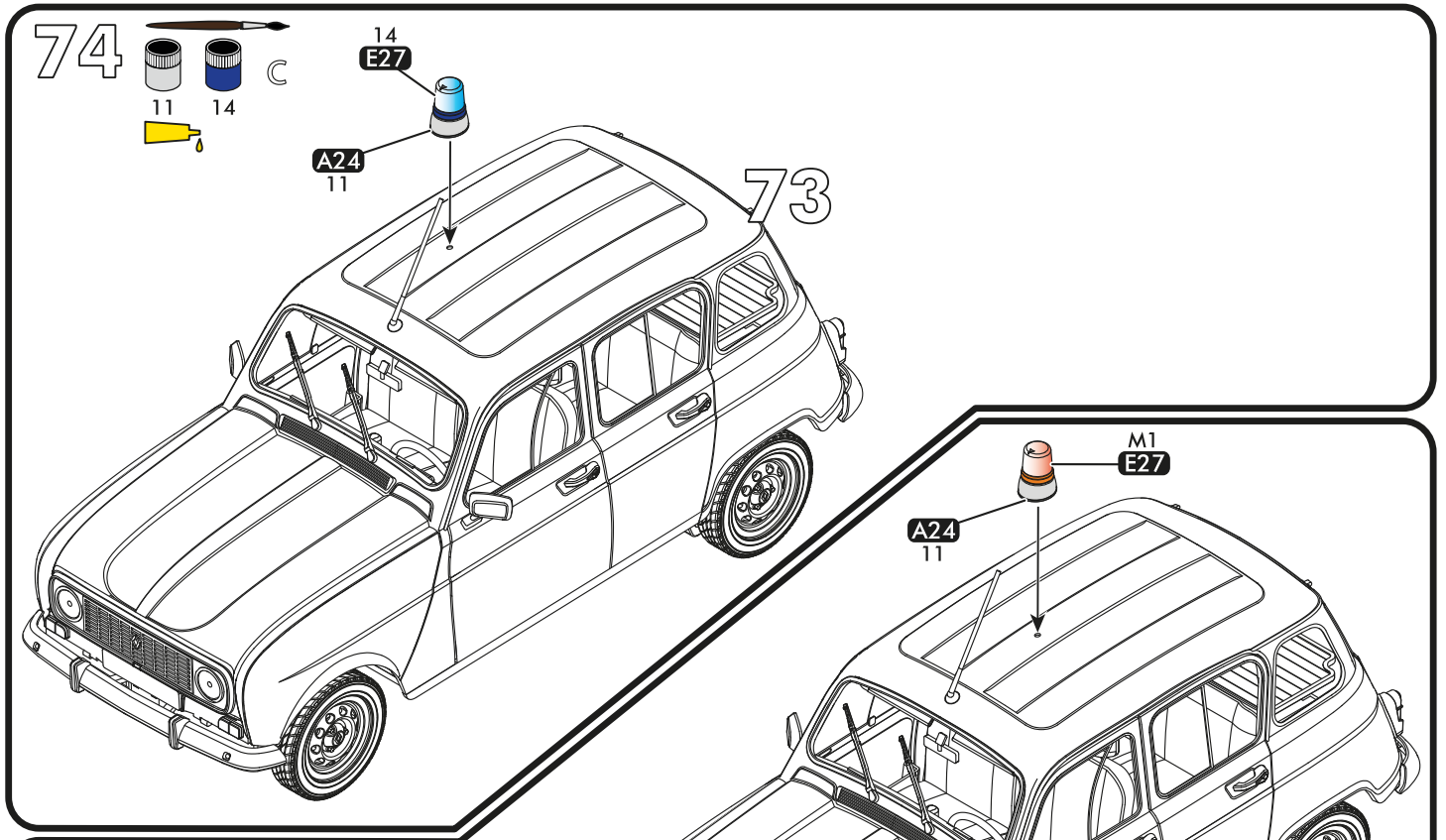
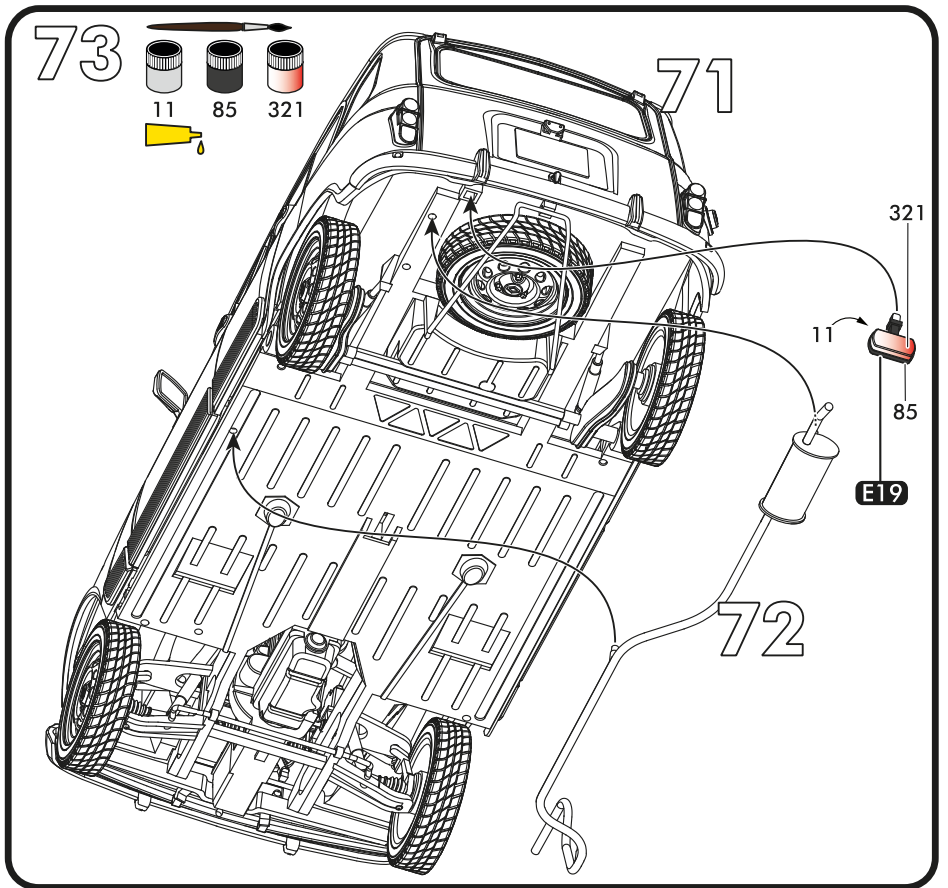
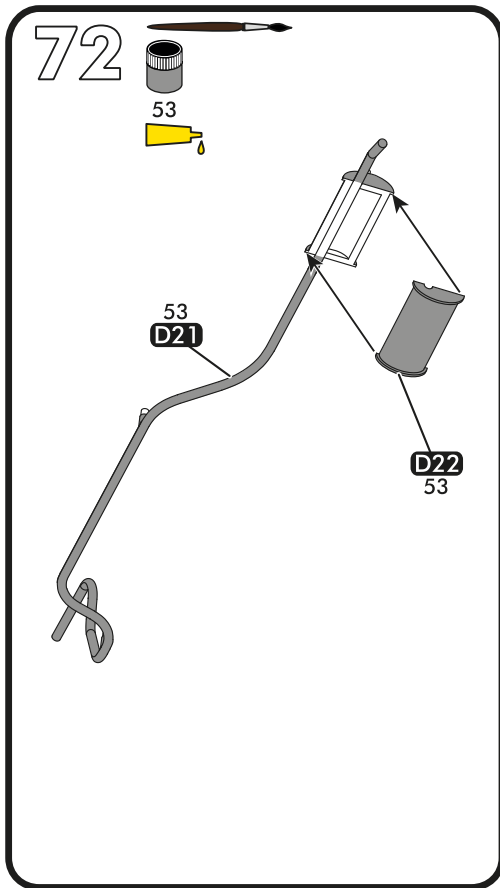

76

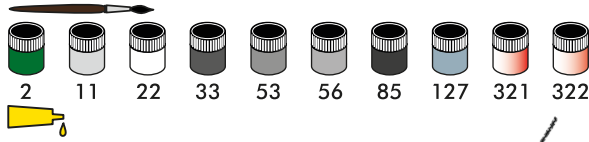

M1
5% 2 + 95% 22

• RENAULT 4 GTL, 1984

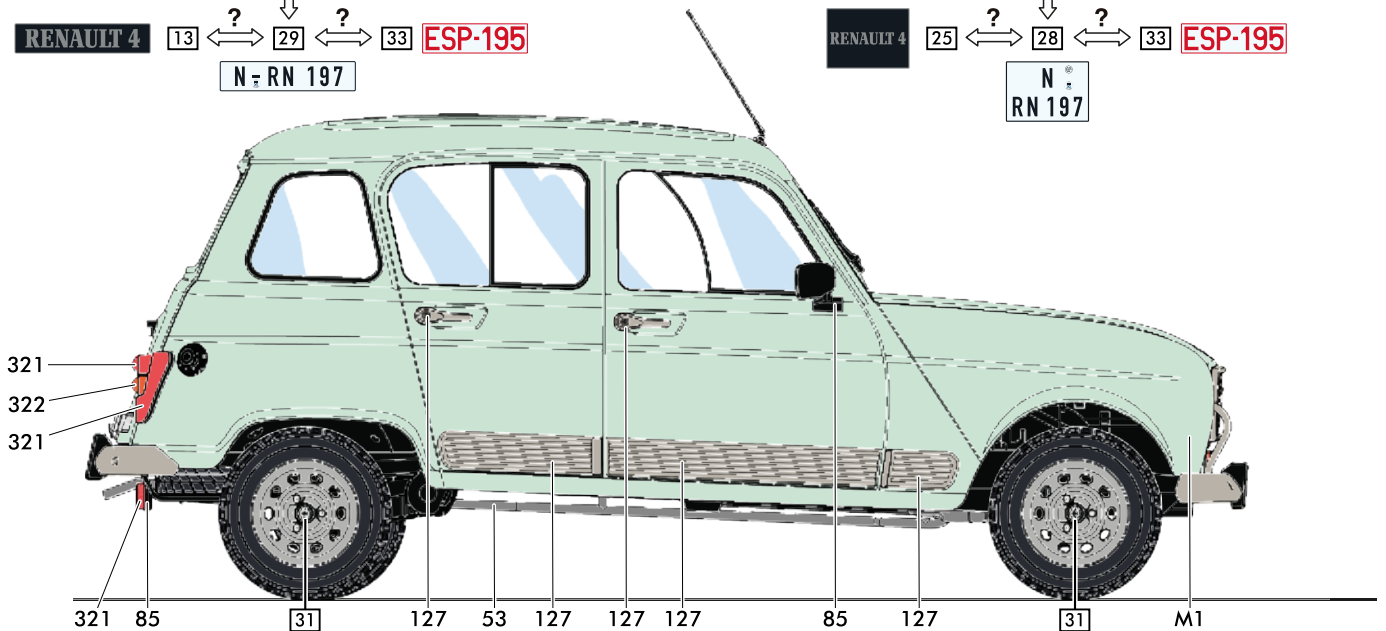
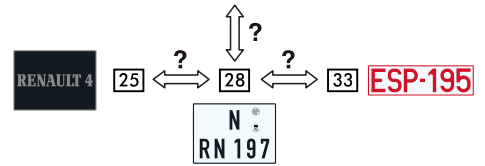
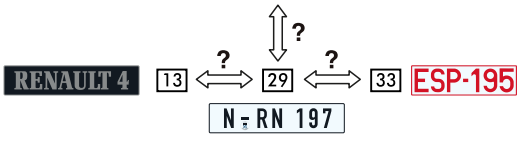
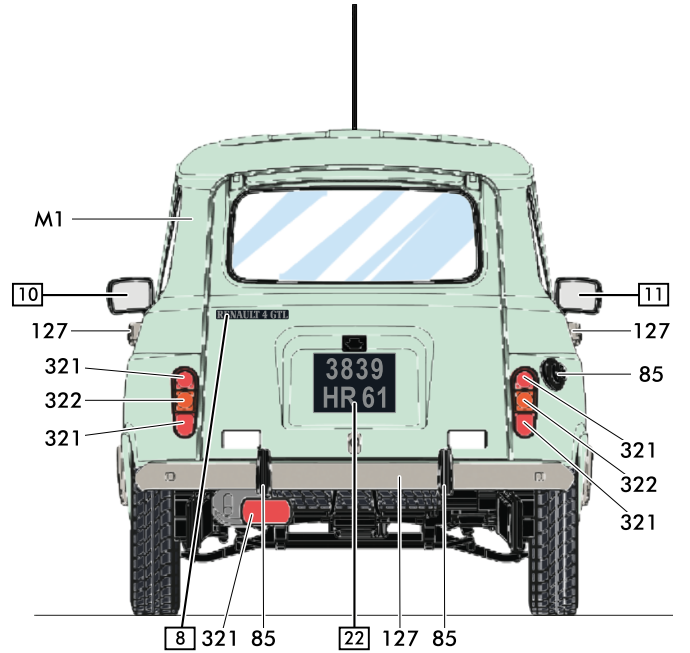
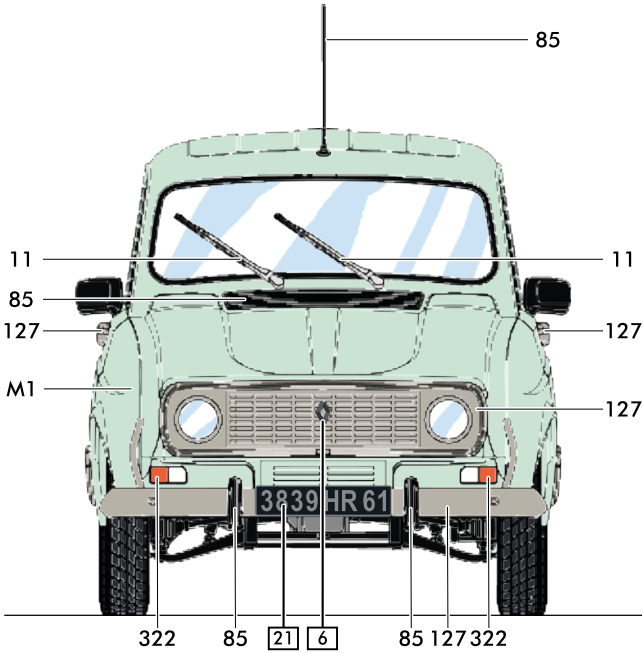
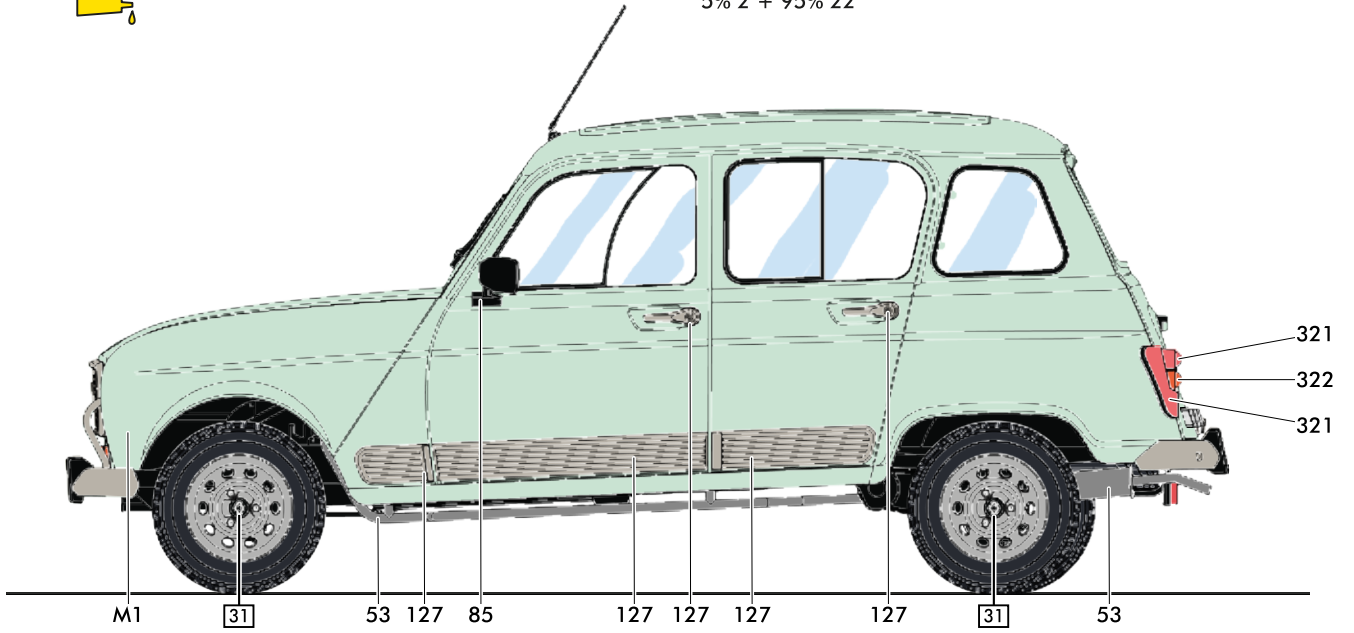

77

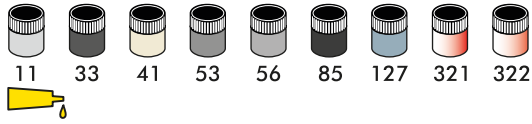

b • RENAULT 4 TL, 1984

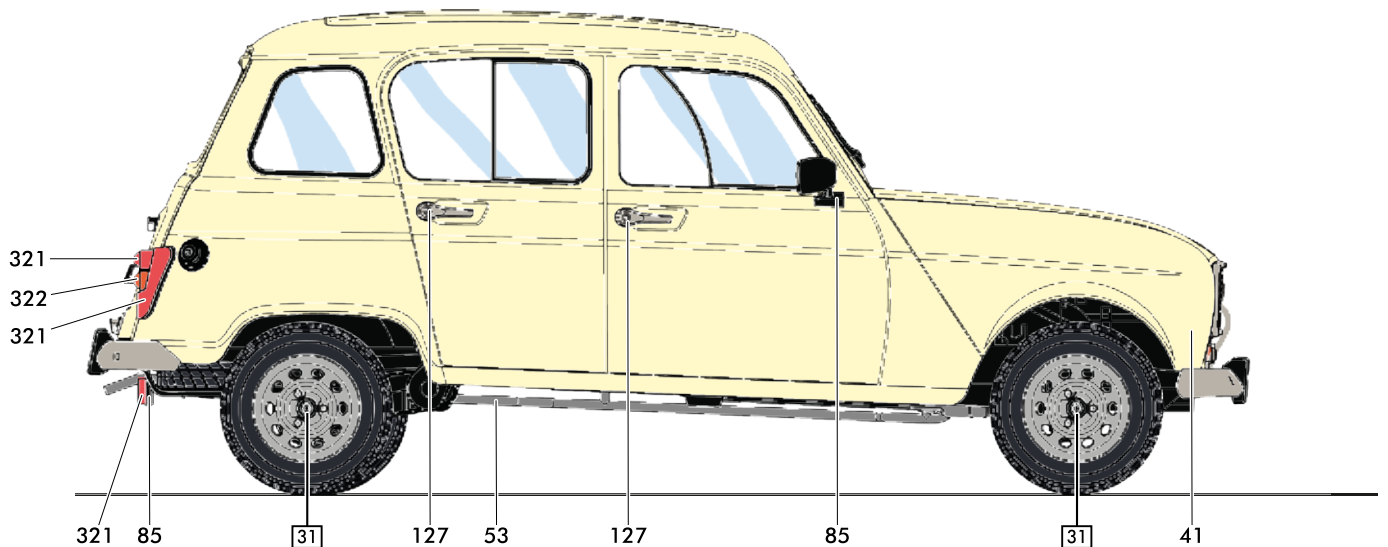
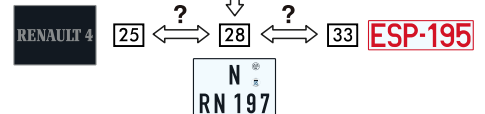
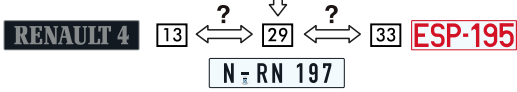
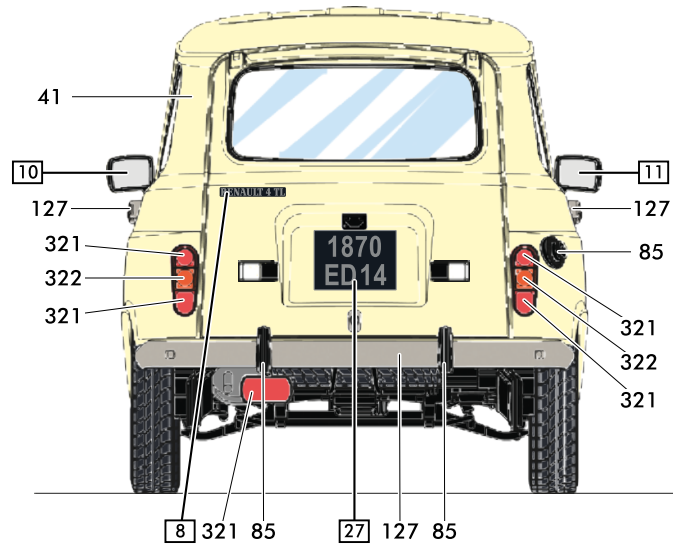
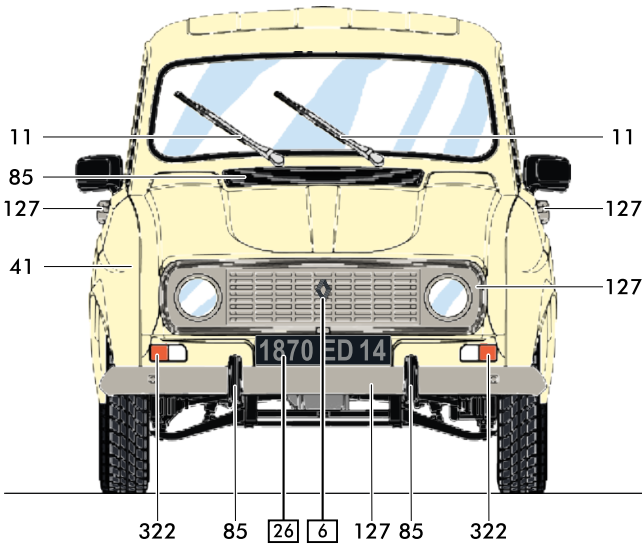
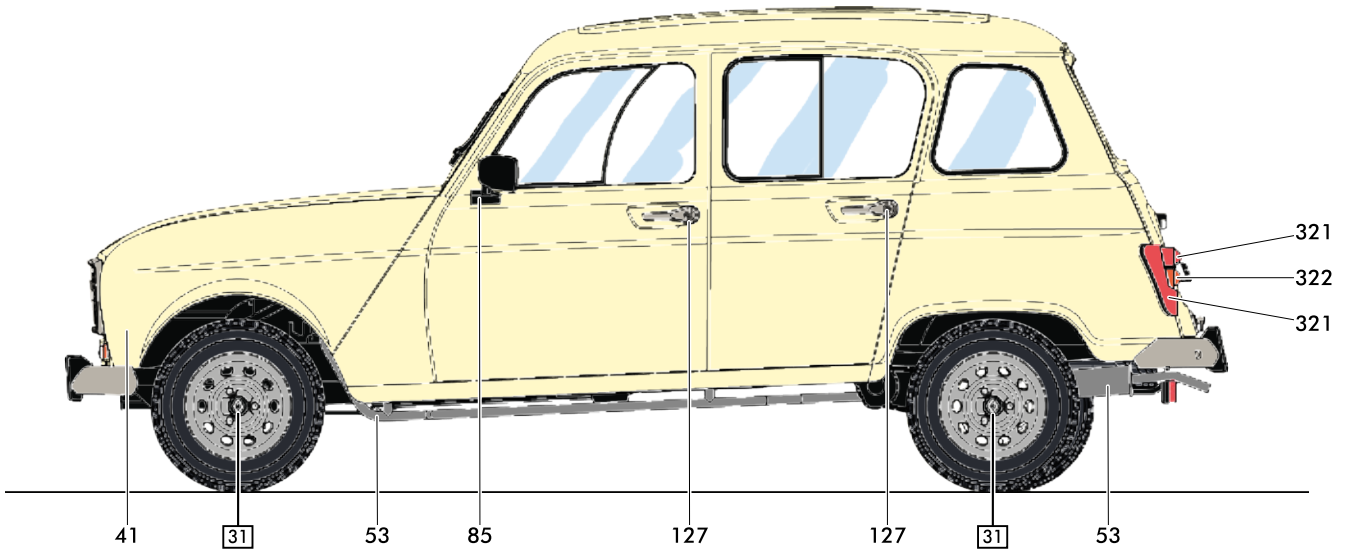

78

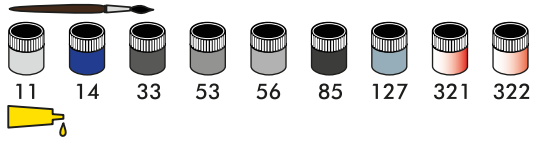

• RENAULT 4 TL Gendarmerie, 1984

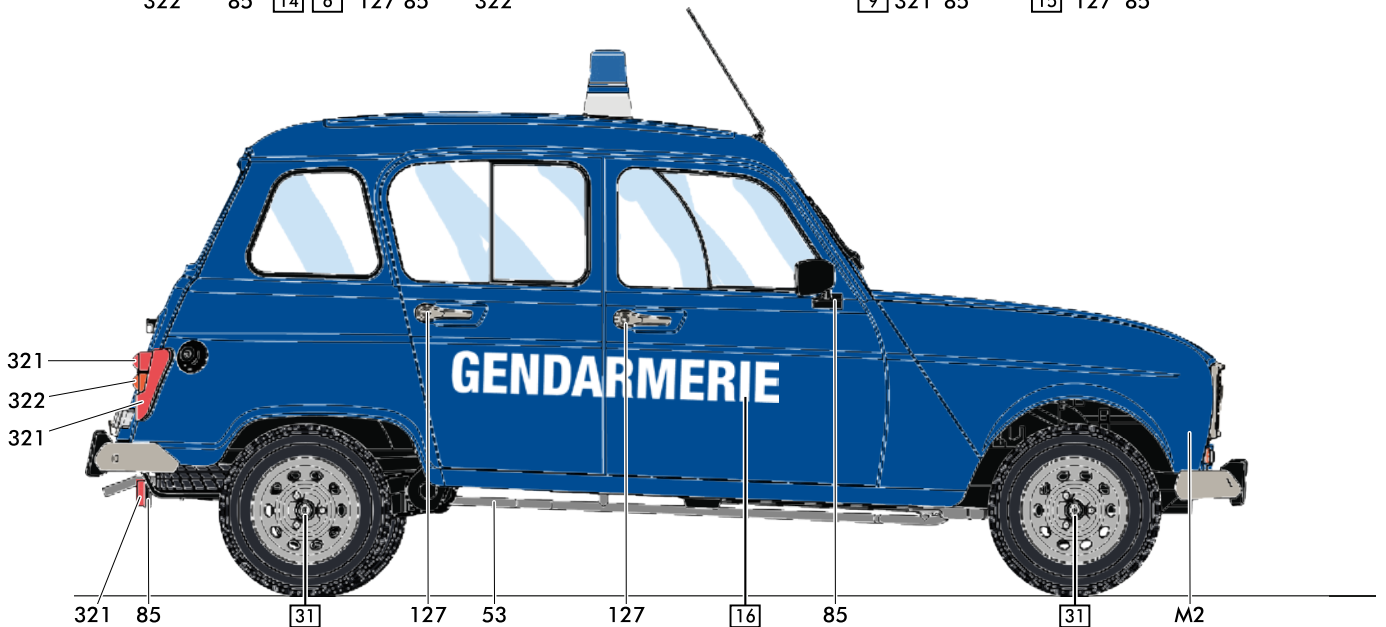
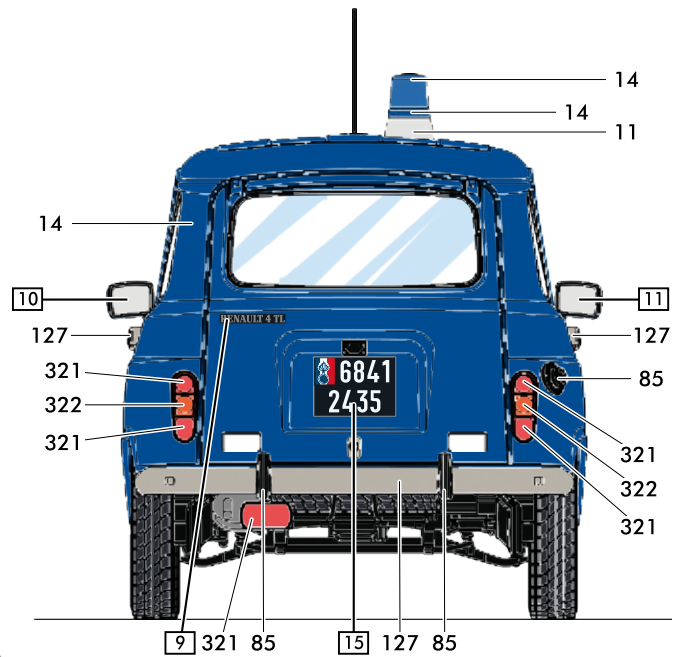
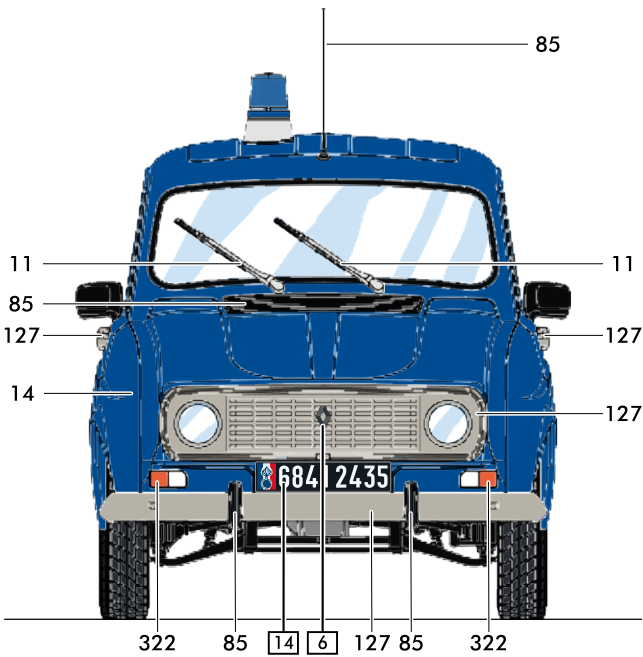
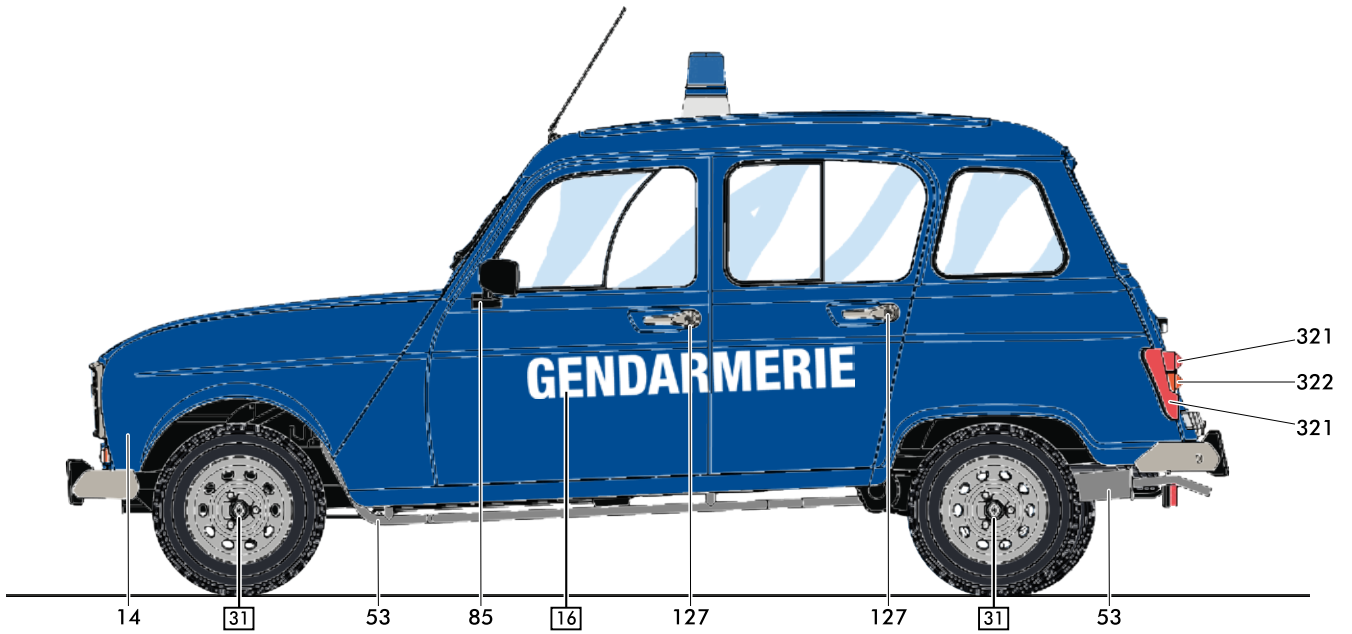

79

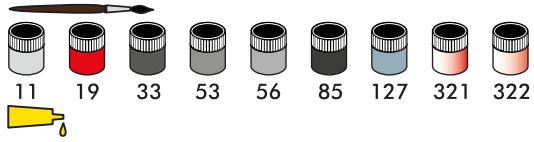

d • RENAULT 4 GTL Sapeurs Pompiers, 1984

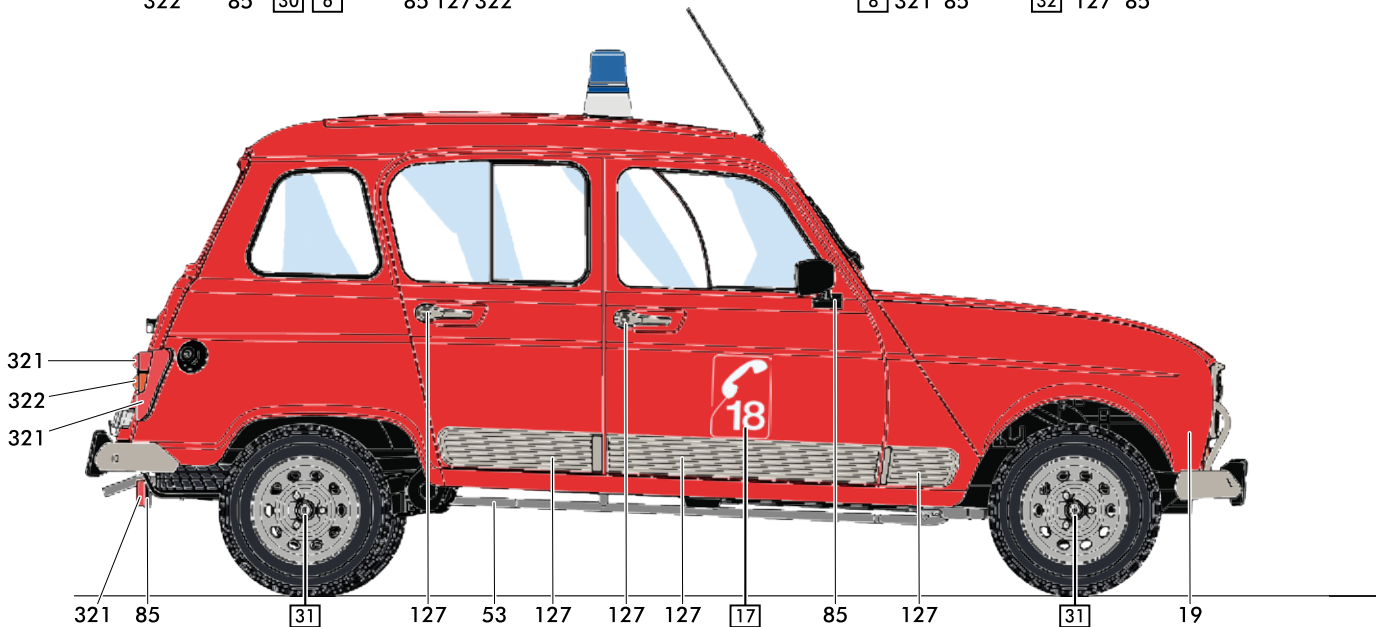
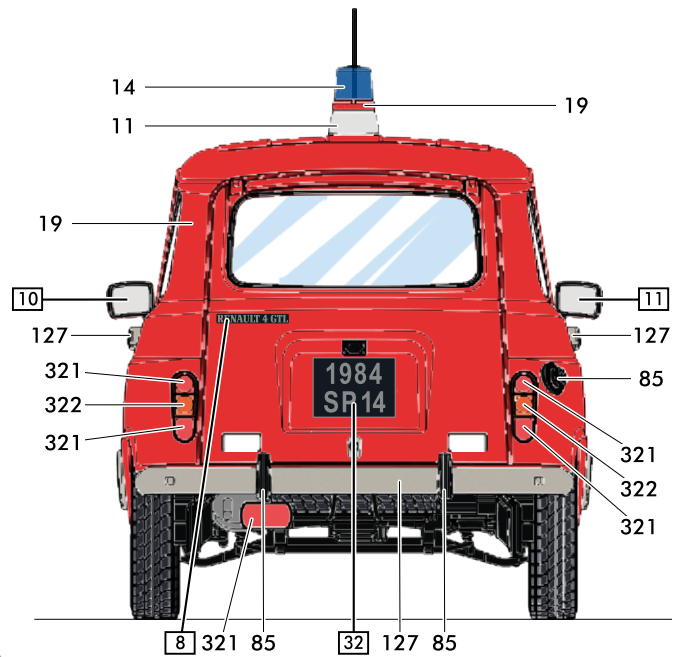
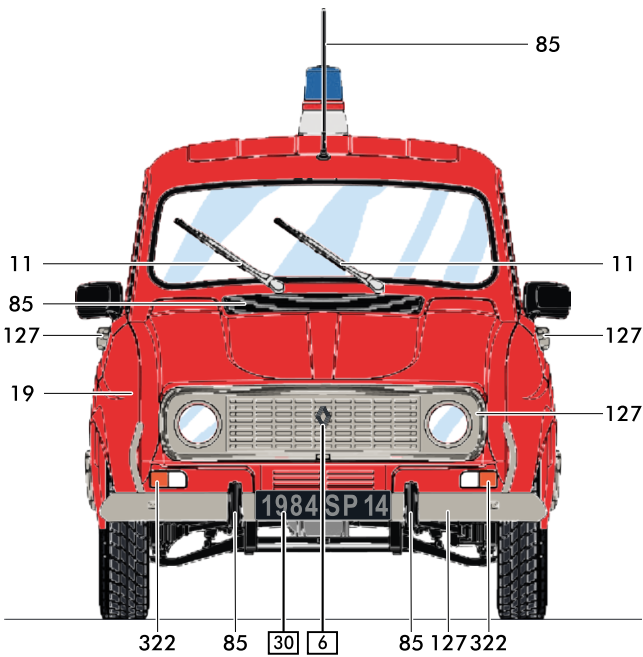
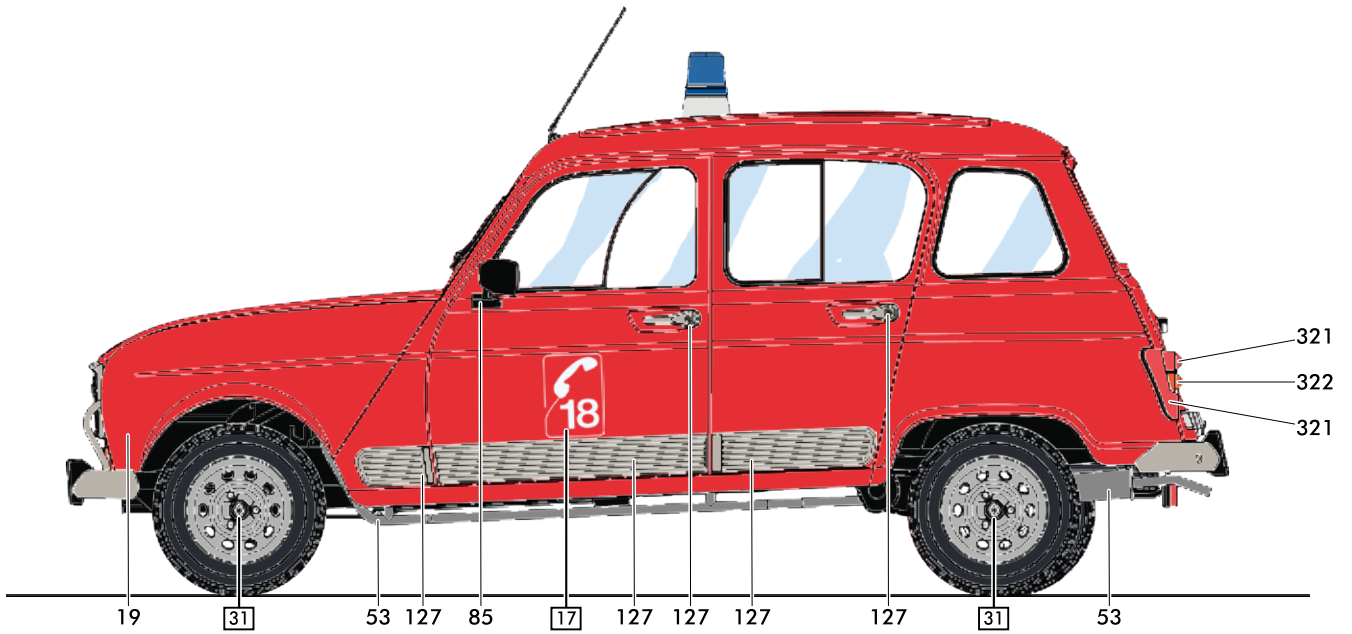

VISITEZ-NOUS EN LIGNE !

VISIT US DIGITALLY!
BESUCHEN SIE UNS DIGITAL!

 www.heller.fr

 [instagram.com/heller.fr](https://www.instagram.com/heller.fr)

 [facebook.com/heller.fr](https://www.facebook.com/heller.fr)

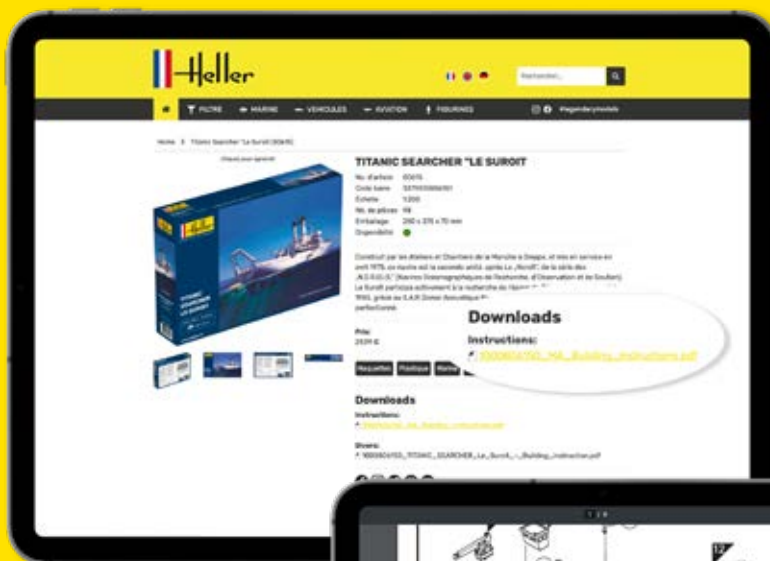

Choisissez l'article que vous désirez et téléchargez les instructions.
Choose your desired article and download the instructions.
Wählen Sie den gewünschten Artikel und laden Sie die Anleitung herunter.

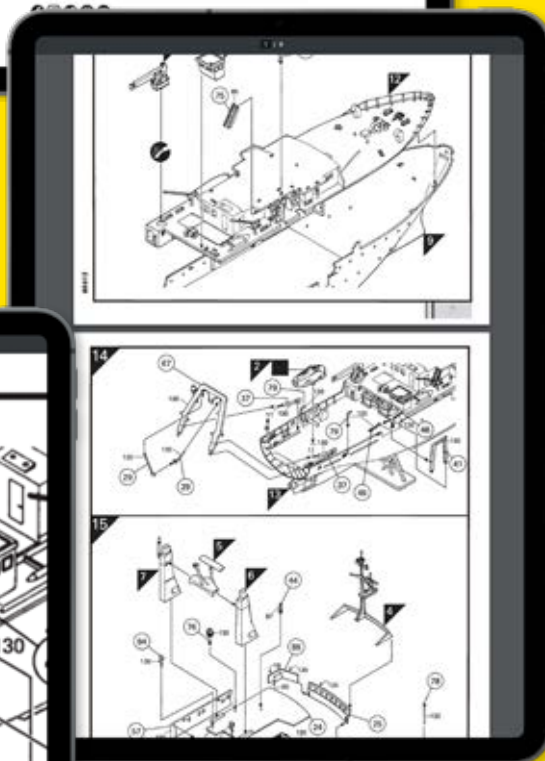

**Download all
instructions!**

Grossissement des instructions pour
une vue détaillée.

Enlarge the instructions for a more
detailed view.

Vergrößern Sie die Anleitung für eine
detailliertere Ansicht.

V-070421

Service consommateurs
Pour toute demande de SAV, connectez-vous
sur notre site www.heller.fr.

Customer Service
For after-sales service requests,
please contact us through our website
www.heller.fr.

Endverbraucherservice
Bitte besuchen Sie uns auf www.heller.fr
für alle Ersatzteilanfragen.

Heller Hobby GmbH

Erlenbacher Str. 3 • 42477 Radevormwald • GERMANY

☎ +49 (0) 2195-92773-0 ✉ info@heller.fr