

# TURNHALLE

SPORTS HALL  
SALLE DE SPORTS  
SPORTHAL

# FALLER

Art. Nr. 130613

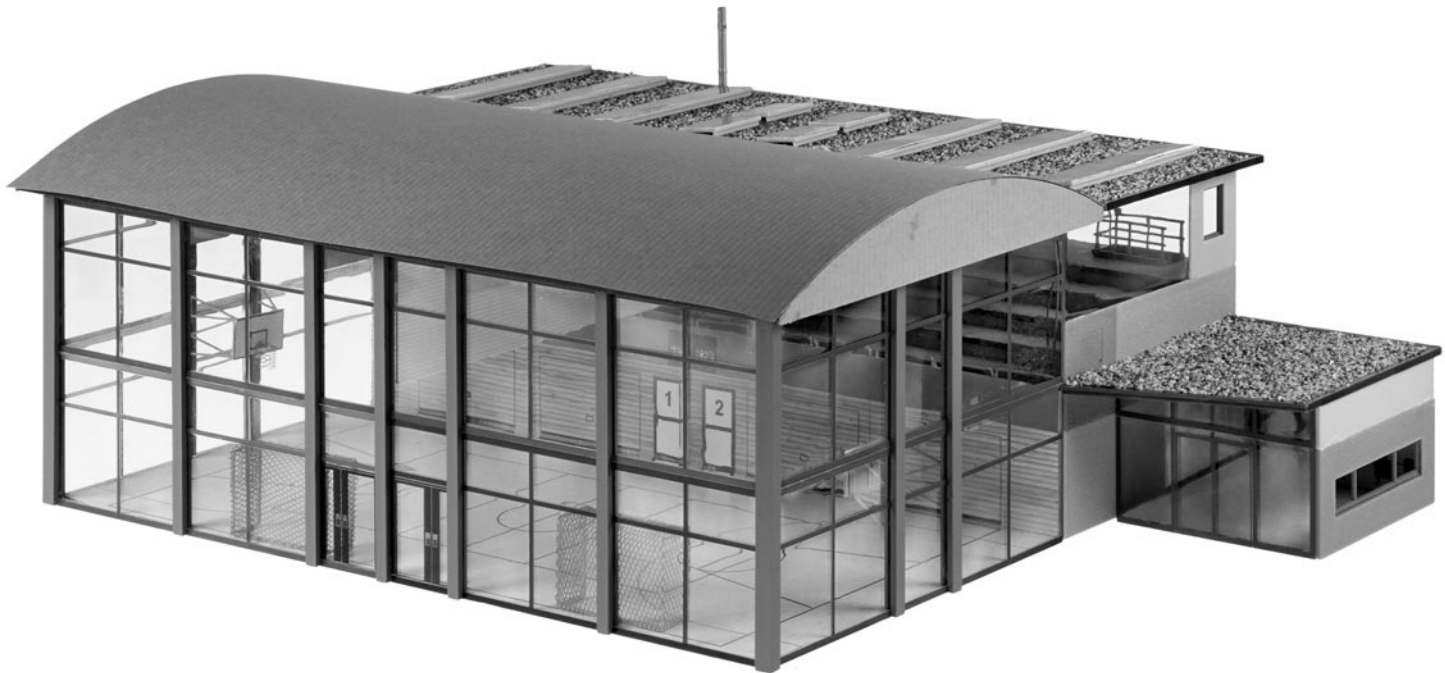

Sa. Nr. 130 613 1

(D)

Vor Beginn des Bastelns sollten Sie sich mit den Spritzlingen und der Anleitung vertraut machen. Sollte es einmal vorkommen, dass ein Teil im Bausatz fehlt, kreuzen Sie bitte das fehlende Teil in der Anleitung an und schicken Sie diese bitte an Fa. Gebr. FALLER GmbH, Abt. Kundendienst, kundendienst@faller.de, Kreuzstraße 9, 78148 Gütenbach. Sie erhalten dann umgehend Ersatz. Es kann vorkommen, dass bei einem Bausatz Einzelteile übrig sind.

(GB)

Before beginning with the assembly please familiarize yourself with the parts and read the instructions carefully. In case of missing parts please indicate these on the instructions leaflet with a circle and return the leaflet to Gebr. FALLER GmbH, kundendienst@faller.de, Kreuzstraße 9, D-78148 Gütenbach, Germany. You will receive the replacement by return. It may happen in a kit that some parts are not required.

(F)

Avant de commencer le montage de votre maquette bien lire la notice et repérer les grappes. Si une pièce manque dans une boîte, cochez la pièce correspondante sur la notice et renvoyez-la-nous à Gebr. FALLER GmbH, kundendienst@faller.de, Kreuzstraße 9, D-78148 Gütenbach (R.F.A.). Nous vous ferons parvenir la pièce par retour. Dans certains kits, il est possible que certaines pièces ne soient pas utilisées.

(NL)

Vóór het bouwen zou men de gietstukken en de handleiding moeten bestuderen. Indien onverhoopt een onderdeel aan het bouwpakket ontbreekt, gelieve men het ontbrekende deel in de handleiding aan te kruisen en deze te zenden aan Gebr. FALLER GmbH, kundendienst@faller.de, Kreuzstraße 9, D-78148 Gütenbach. U ontvangt dan omgaand en gratis het ontbrekende onderdeel. Het kan voorkomen dat u bij bepaalde bouwdozen onderdelen overhoudt.

Für den Zusammenbau des Modells empfehlen wir folgende FALLER-Artikel (sind nicht im Bausatz enthalten):  
For the assembly of the kit we recommend following FALLER products (not included in the kit):  
Pour l'assemblage du modèle, nous vous recommandons les articles FALLER suivants (non inclus dans le kit):  
Om dit model te bouwen adviseren wij de volgende FALLER producten (maken geen deel uit van deze bouwset):

Art. Nr. 170492  
FALLER-EXPERT

Flüssigkleber in Plastikflasche mit Spezialkanüle für feinste Klebstoffdosierung.

Liquid cement in plastic bottle with canule for very fine dosage.

Colle liquide en bouteille plastique avec bec verseur pour un dosage précis.

Vloeibare lijm in plastic-flescon met doseerbuisje om nauwkeurig te lijmen.



Art. Nr. 170688  
SPEZIAL-SEITENSCHNEIDER

zum gratfreien Abtrennen von feinsten Spritzteilen. Nur für Polystyrol geeignet.

Special side cutter for cutting off ultra-fine moulded parts without burrs. Only suitable for polystyrene.

Pince coupante spéciale pour couper sans bavure les pièces miniatures moulées par injection. Convient uniquement au polystyrène.

Speciale zijknijptang voor het braamloos afknippen van de fijnste gietstukdelen. Alleen geschikt voor polystyrol.



(D)

Für die Montage benötigen Sie:

FALLER-Klebstoff EXPERT (Art. Nr. 170492)  
FALLER EXPERT-LASERCUT (Art. Nr. 170494)  
FALLER-Colofix (Art. Nr. 170501)  
Alleskleber  
FALLER-Spezial-Seitenschneider (Art. Nr. 170688)  
FALLER-Bastelmesser (Art. Nr. 170687)

(GB)

For mounting you need:

FALLER cement EXPERT (Art. No. 170492)  
FALLER EXPERT LASERCUT (Art. No. 170494)  
FALLER-Colofix (Art. No. 170501)  
All-purpose glue  
FALLER special side cutter (Art. No. 170688)  
FALLER modeller's knife (Art. No. 170687)

(F)

Pour le montage, utiliser :

Colle FALLER EXPERT (Art. Nr. 170492)  
FALLER EXPERT LASERCUT (Art. Nr. 170494)  
FALLER-Colofix (Art. Nr. 170501)  
Colle universelle  
Pince coupante diagonale spéciale FALLER (Art. Nr. 170688)  
Couteau de bricolage FALLER (Art. Nr. 170687)

(NL)

Voor de montage heeft u :

FALLER-plasticlijm EXPERT (Art. Nr. 170492)  
FALLER EXPERT LASERCUT (Art. Nr. 170494)  
FALLER-Colofix (Art. Nr. 170501)  
Universele lijm  
FALLER-speciaal zijknijptang (Art. Nr. 170688)  
FALLER-knutselmes (Art. Nr. 170687)

2

<b>Inhalt</b>	Spritzlinge Tüte 1	T 1
<b>Contents</b>	Moulded parts bag 1	T 1
<b>Contenu</b>	Grappes sachet 1	T 1
<b>Inhoud</b>	Spuitsietstuk zakje 1	T 1
	7 A	III 6 x
	7 A	III T.r. 1 x
	7 A	III T.l. 1 x

<b>Inhalt</b>	Spritzlinge Tüte 2	T 2
<b>Contents</b>	Moulded parts bag 2	T 2
<b>Contenu</b>	Grappes sachet 2	T 2
<b>Inhoud</b>	Spuitsietstuk zakje 2	T 2
	5 C	4 x
	5 C	1 1 x
	5 C	2 1 x
	5 C	3 1 x
	5 C	4 1 x
	5 C	5 1 x

<b>Inhalt</b>	Spritzlinge Tüte 3	T 3
<b>Contents</b>	Moulded parts bag 3	T 3
<b>Contenu</b>	Grappes sachet 3	T 3
<b>Inhoud</b>	Spuitsietstuk zakje 3	T 3
	1 A	I 1 x
	1 A	II 1 x
	1 A	III 1 x
	1 A	IV 1 x
	5 A	1 x
	5 A	1 x
	5 A	1 x

<b>Inhalt</b>	Spritzlinge Tüte 4	T 4
<b>Contents</b>	Moulded parts bag 4	T 4
<b>Contenu</b>	Grappes sachet 4	T 4
<b>Inhoud</b>	Spuitsietstuk zakje 4	T 4
	3 B	1 x
	9 A	2 x
	11 AC	2 x

<b>Inhalt</b>	Karton	1 ADE	1 x	1 D	1 x	2/3	1 x	3 B	1 x	8 AB	1 x	15	1 x
<b>Contents</b>	Carton	1 CE	1 x	1 DE	1 x	2/7	1 x	4 B	1 x	12	1 x	26 AC	2 x
<b>Contenu</b>	Carton	1 CE	1 x	2	1 x	2/12	1 x	4 BD	1 x	13	1 x	26 D	1 X
<b>Inhoud</b>	Karton	1 CE	1 x	2/1	1 x	2/14	1 x	6 C	2 x	14	1 x		

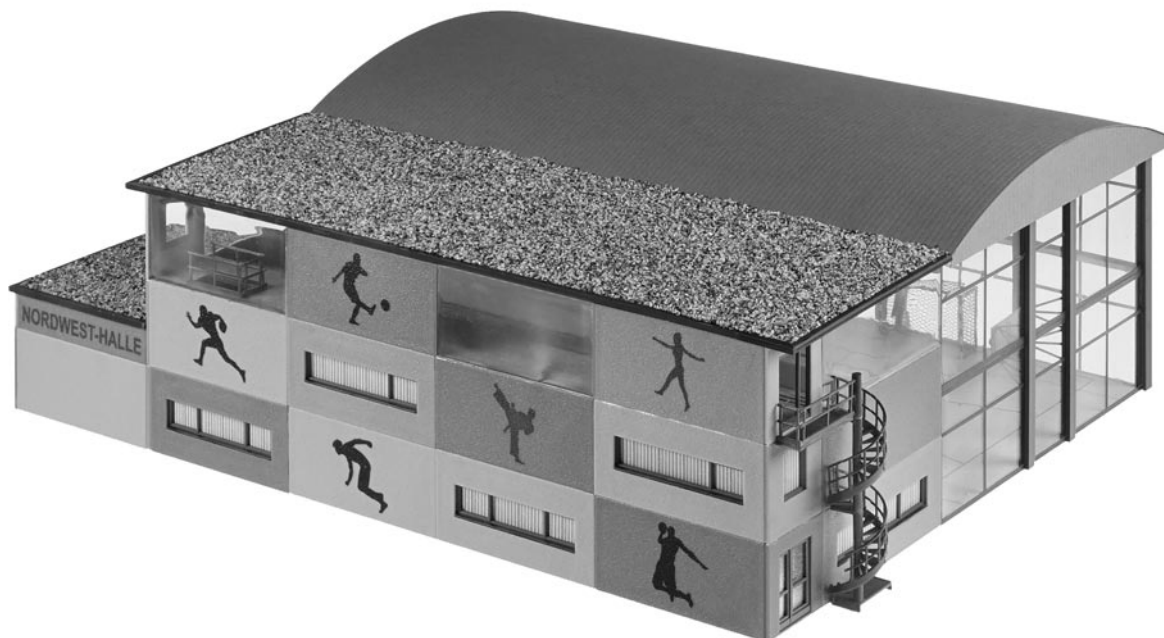
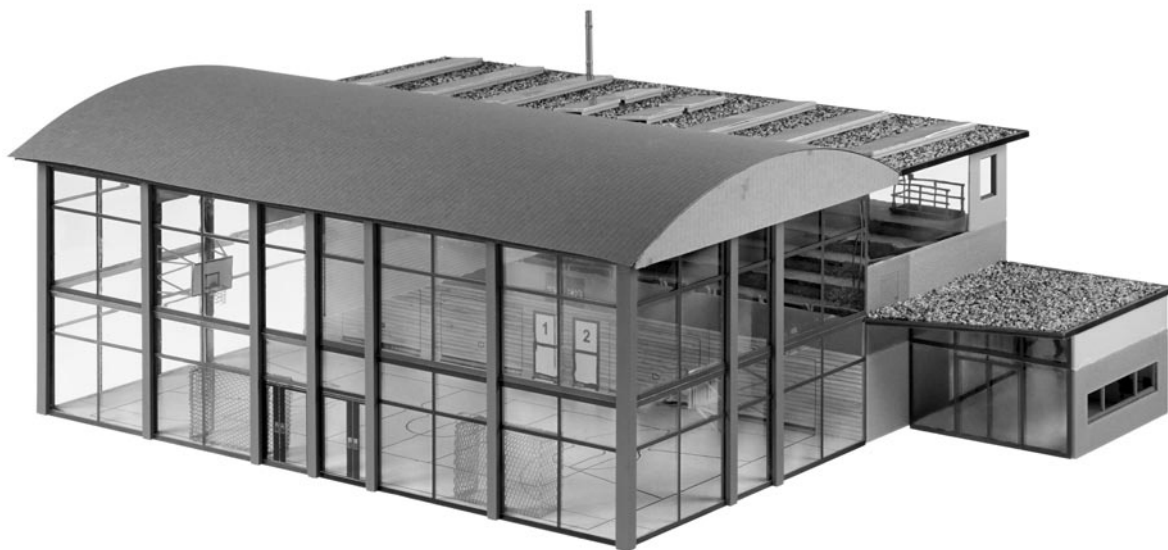

#### Fensterfolie

Die beiliegende Fensterfolie entsprechend der benötigten Größe ausschneiden und vorsichtig mit wenig Klebstoff auf die Rückseite der Fensterrahmen aufkleben.

#### Window foil

Cut the attached window foil according the illustrations and glue it carefully with a little glue to the rear side of the window frames.

#### Feuillet transparent pour fenêtres

Découper le feuillet transparent pour fenêtres inclus d'après l'illustration. Coller proprement avec un peu de colle sur la face arrière du cadre des fenêtres.

#### Vensterfolie

De meegeleverde vensterfolie conform de afbeeldingen uitknippen of uitsnijden en voorzichtig met een beetje lijm op de achterzijde van het raam plakken.

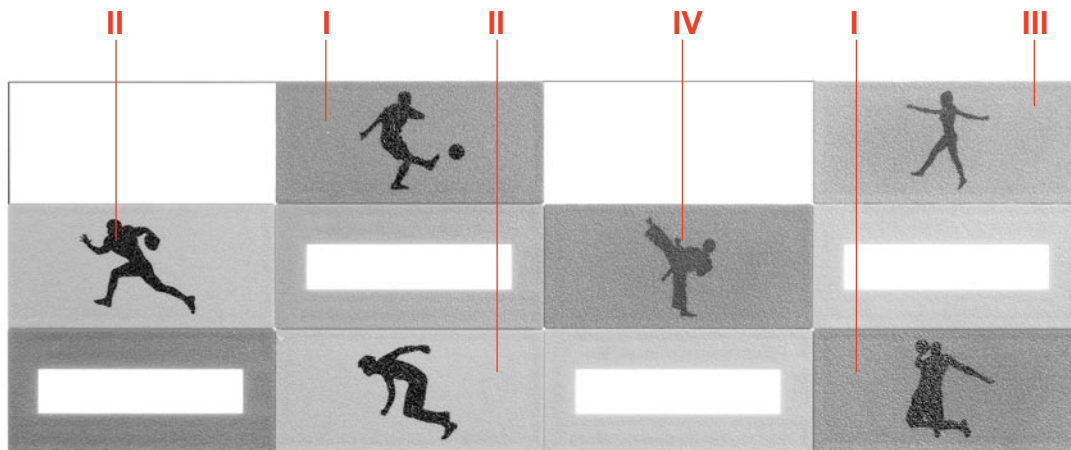

1/4-G III T3 mittel medium moyen medium  
 5/6 T2  
 1/4-G IV T3 dunkel dark sombre donker  
 1/4-G I T3 dunkel dark sombre donker  
 5/4-P T3 mittel medium moyen medium  
 5/6 T2

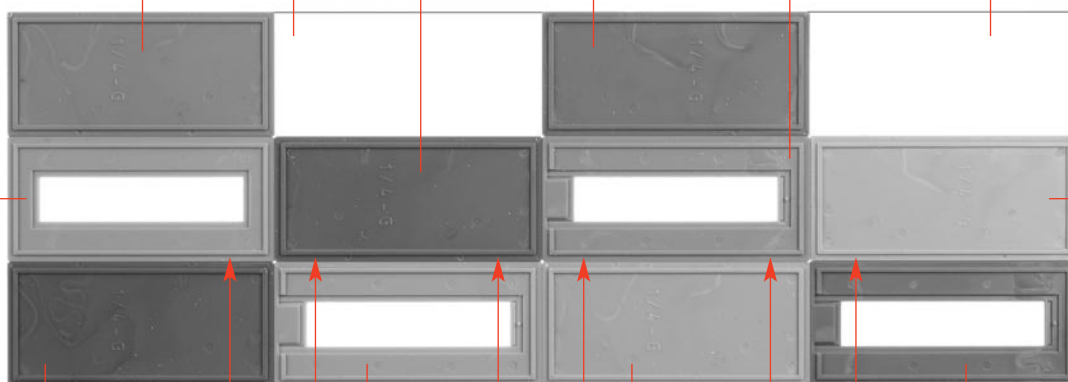

5/1-P hell bright brillant helder  
 T3

1/4-G II hell bright brillant helder  
 T3

**A**

T3 dunkel dark sombre donker  
 1/4-G I  
 1/14  
 5/4-P T3 hell bright brillant helder  
 1/14  
 1/4-G II T3 hell bright brillant helder  
 1/14  
 5/4-P T3 dunkel dark sombre donker

Deco 2

Deco 2

Deco 2

Deco 2

Fensterfolie  
 Window foil  
 Feuillet transparent  
 Vensterfolie

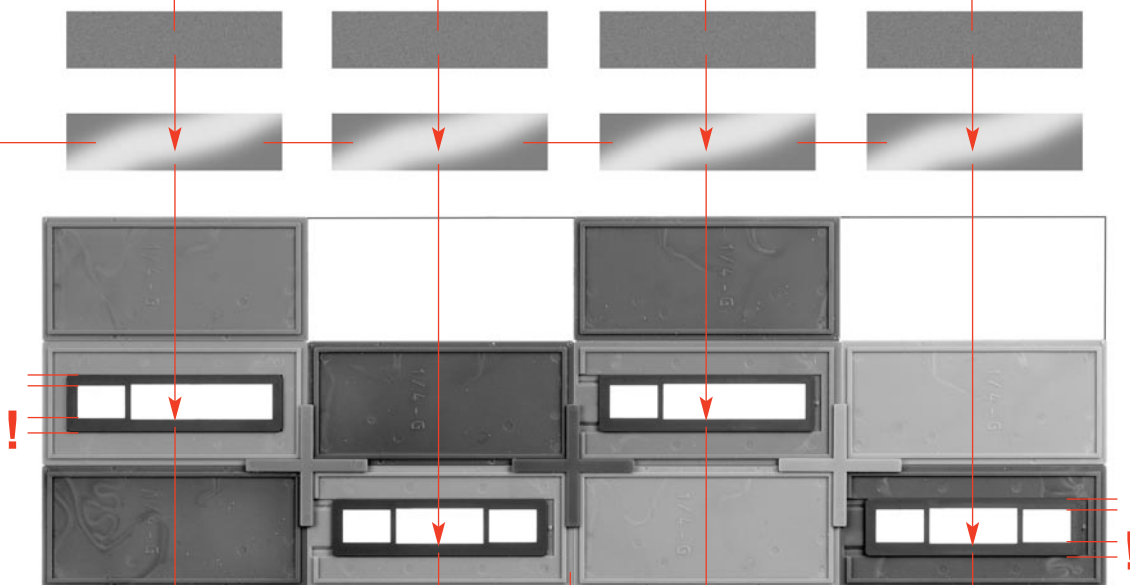

4/5

4/4

**A**

4/5

4/4

**B**

4

5/6 T2 1/9 1/13

hell  
bright  
brillant  
helder

mittel  
medium  
moyen  
medium

1/4-G IV  
T3  
dunkel  
dark  
sombre  
donker

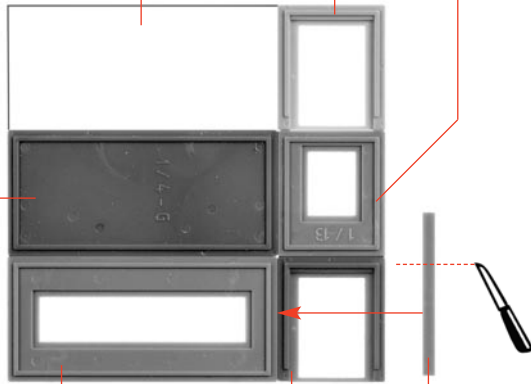

T3  
5/1P  
mittel  
medium  
moyen  
medium

1/9  
dunkel  
dark  
sombre  
donker

1/17

C

Deco 2 3/9 T4 3/6 T4 Deco 4

Fensterfolie  
Window foil  
Feuillet transparent  
Vensterfolie

Fensterfolie  
Window foil  
Feuillet transparent  
Vensterfolie

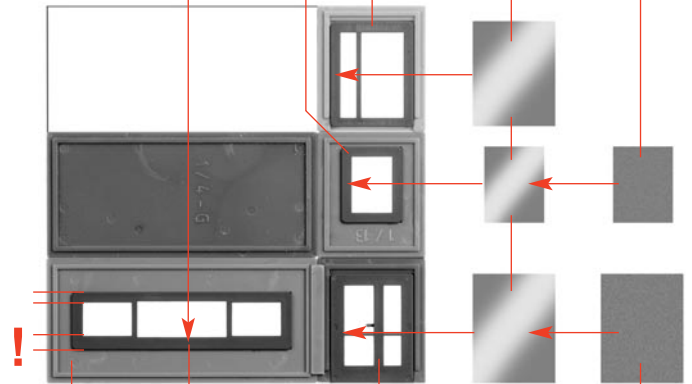

C

4/4

3/10 T4

Deco 3

D

4

1/13 5/6 T2

hell  
bright  
brillant  
helder

mittel  
medium  
moyen  
medium

1/4-G  
T3

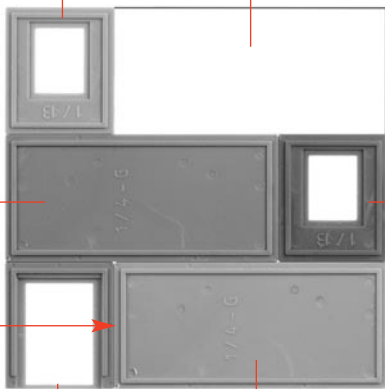

1/17

1/9  
mittel  
medium  
moyen  
medium

1/4-G  
hell  
bright  
brillant  
helder

1/13  
dunkel  
dark  
sombre  
donker

E

Fensterfolie  
Window foil  
Feuillet transparent  
Vensterfolie

3/9 T4

26/13

Deco 3

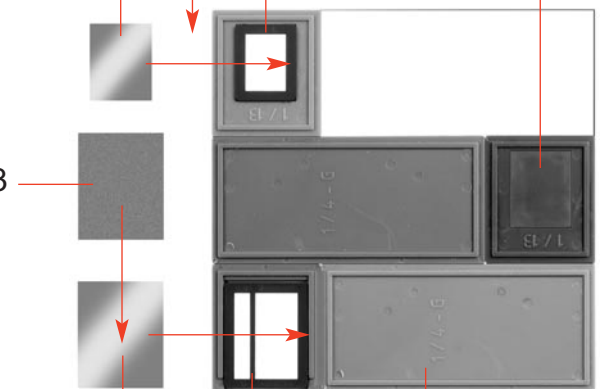

Fensterfolie  
Window foil  
Feuillet transparent  
Vensterfolie

3/6 T4

E

F

Lasercut-Kleber verwenden.  
Use Lasercut glue.  
Utilisez la colle Lasercut.  
Gebruik Lasercutlijm.

2/4

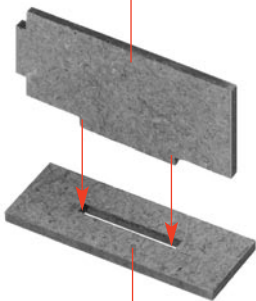

G 3 x

2/5

G

Lasercut-Kleber verwenden.  
Use Lasercut glue.  
Utilisez la colle Lasercut.  
Gebruik Lasercutlijm.

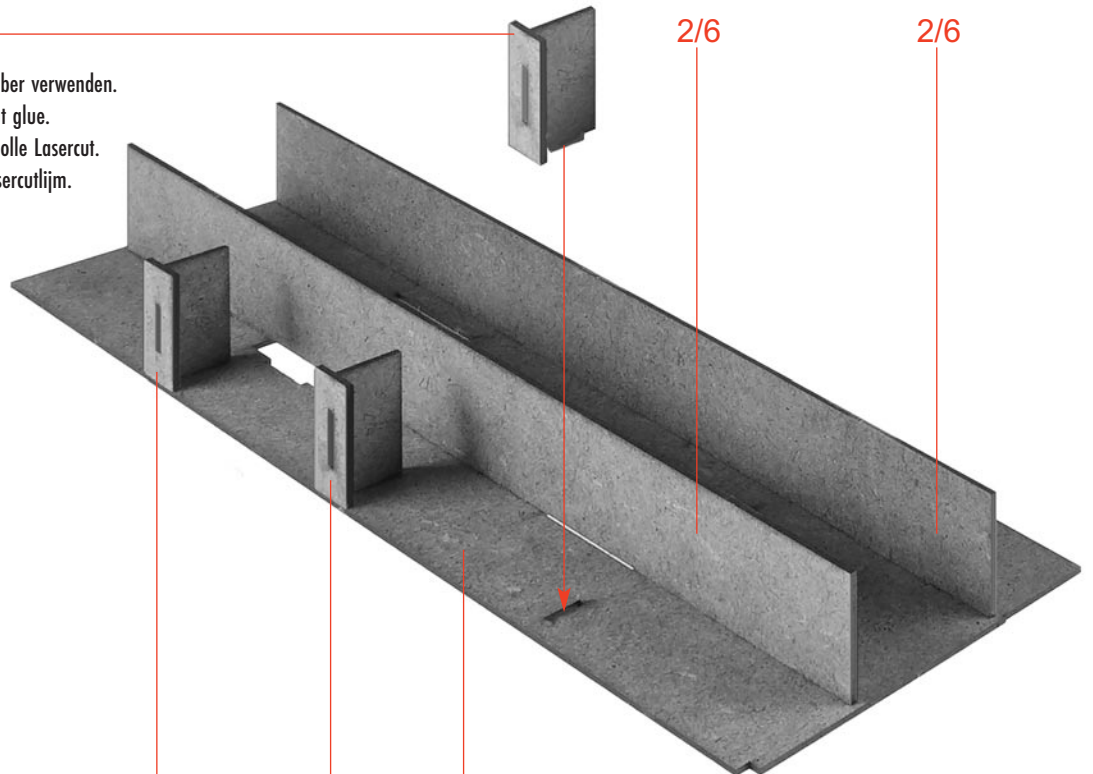

2/6

2/6

H

G

G

2/3

Mit Alleskleber kleben.  
Use all-purpose glue.  
Utiliser de la colle universelle.  
Met een universele lijm lijmen.

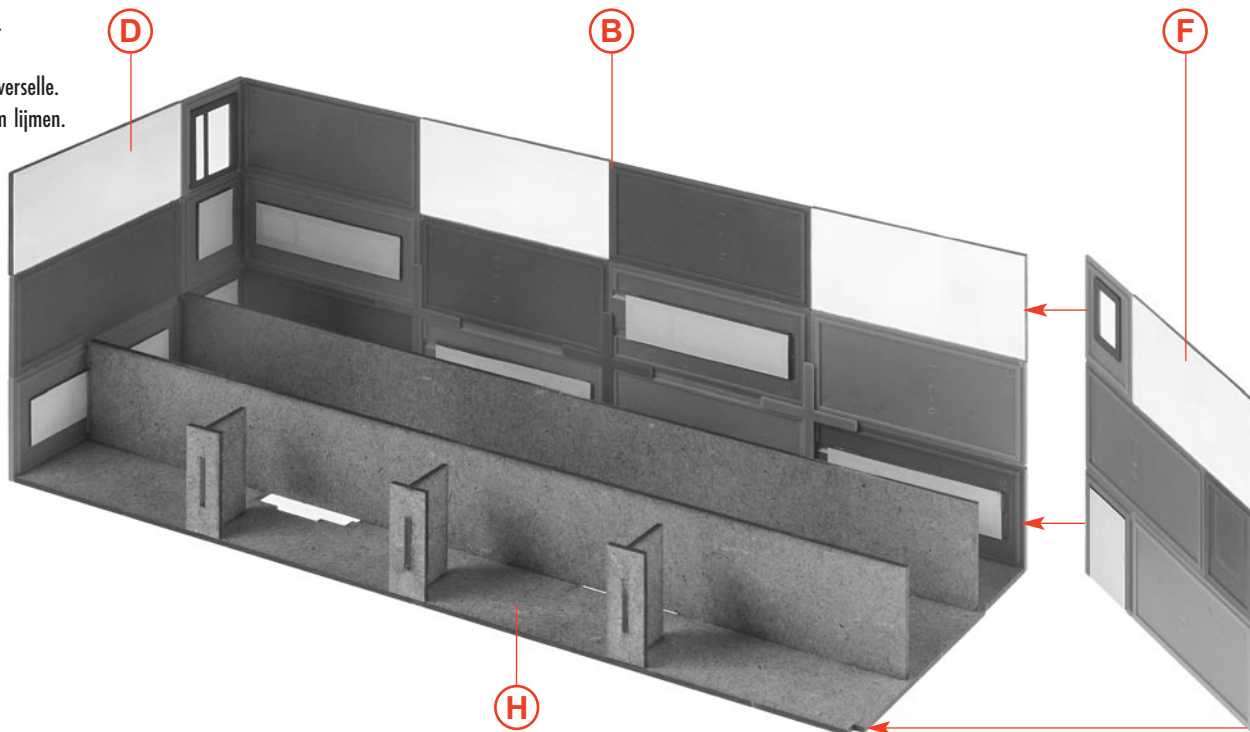

I

Lasercut-Kleber verwenden.  
Use Lasercut glue.  
Utilisez la colle Lasercut.  
Gebruik Lasercutlijm.

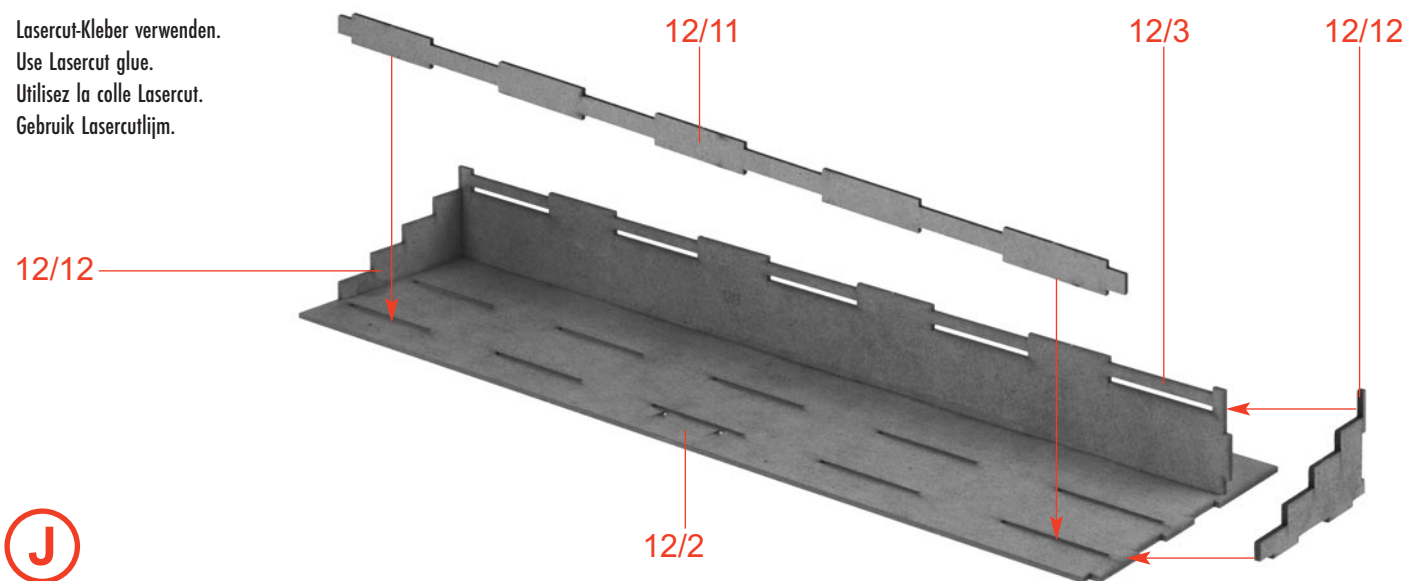

J

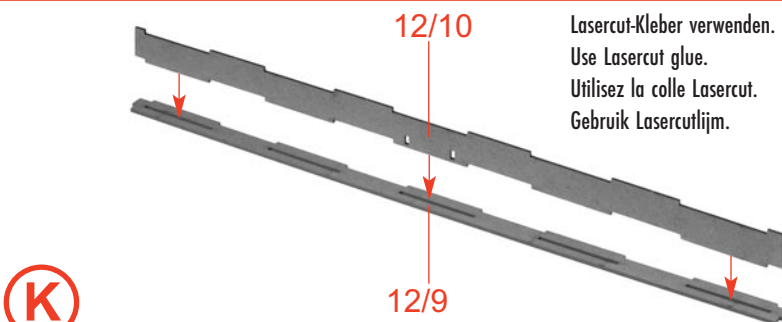

K

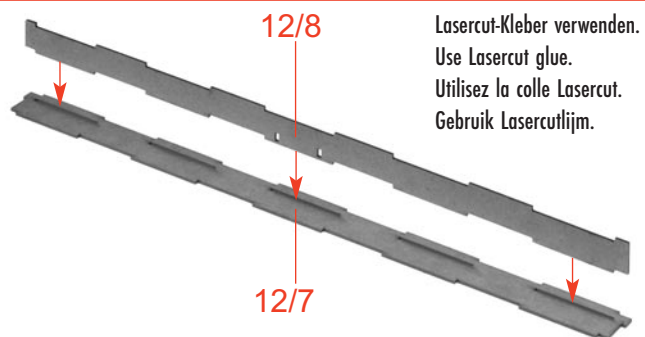

L

Lasercut-Kleber verwenden.  
Use Lasercut glue.  
Utilisez la colle Lasercut.  
Gebruik Lasercutlijm.

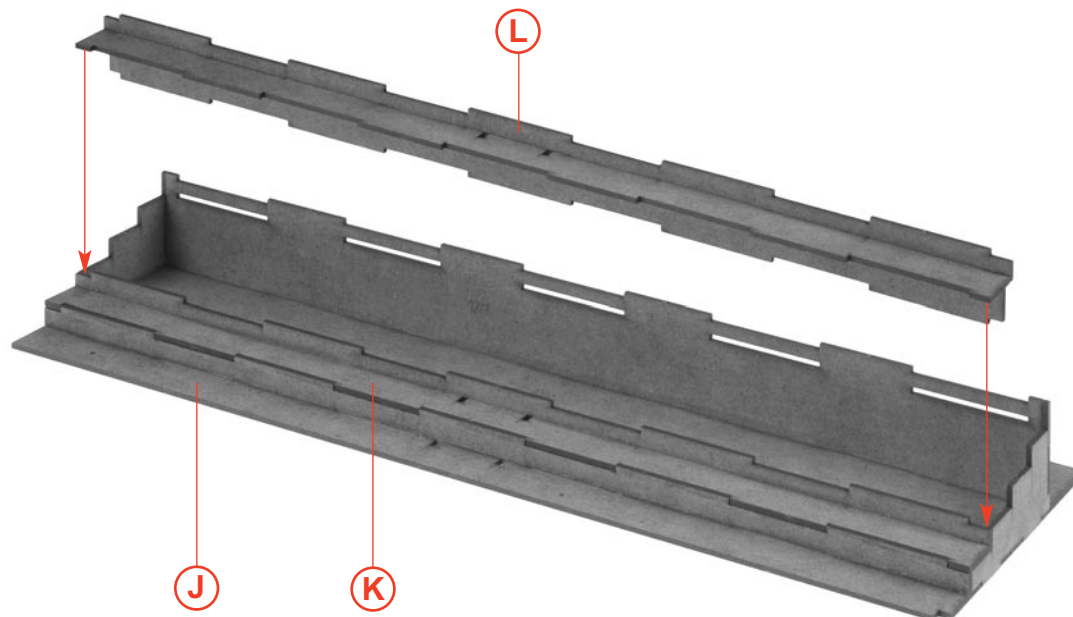

M

J

K

L

**6** Lasercut-Kleber verwenden.  
Use Lasercut glue.  
Utilisez la colle Lasercut.  
Gebruik Lasercutlijm.

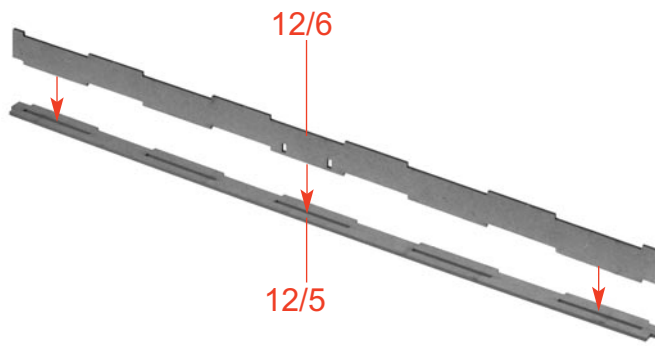

**N**

Lasercut-Kleber verwenden.  
Use Lasercut glue.  
Utilisez la colle Lasercut.  
Gebruik Lasercutlijm.

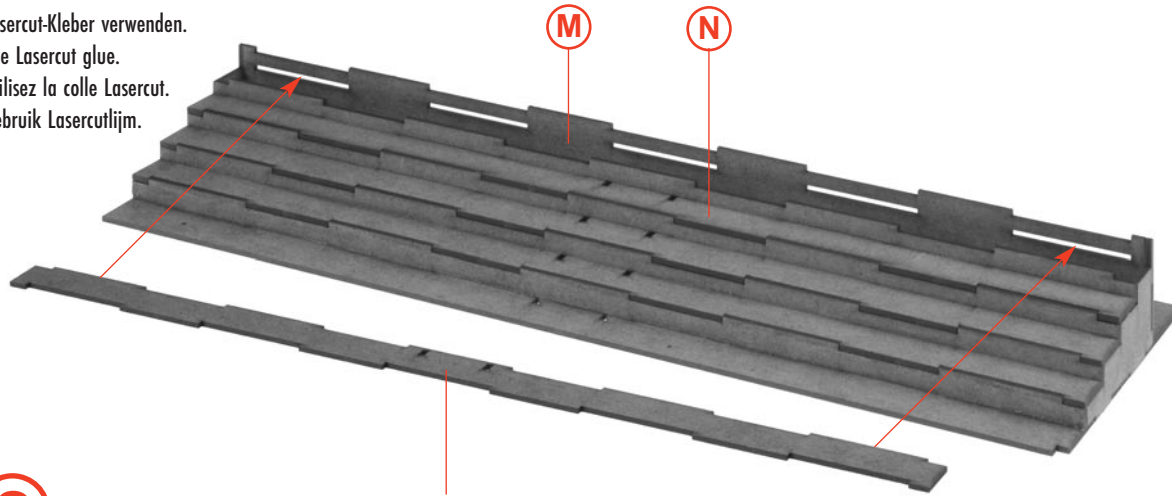

12/4

Lasercut-Kleber verwenden.  
Use Lasercut glue.  
Utilisez la colle Lasercut.  
Gebruik Lasercutlijm.

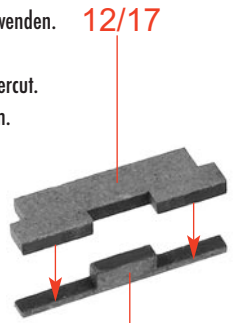

**P** 5 x

12/18

Lasercut-Kleber verwenden.  
Use Lasercut glue.  
Utilisez la colle Lasercut.  
Gebruik Lasercutlijm.

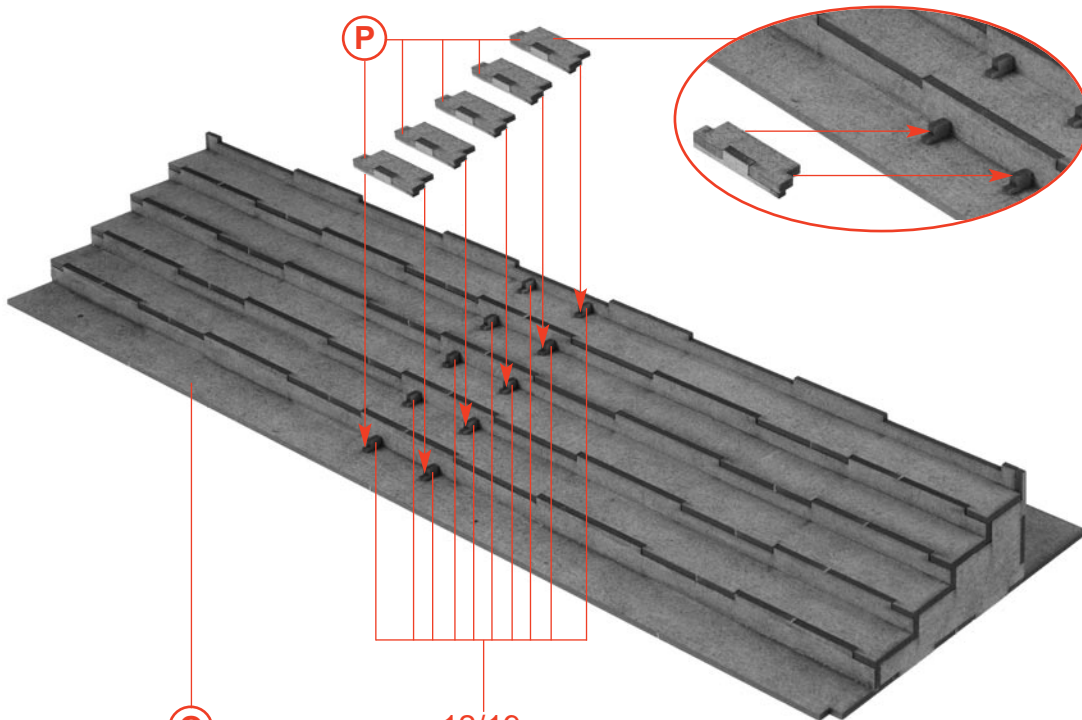

12/19

**Q**

**O**

12/13  
Lasercut-Kleber verwenden.  
Use Lasercut glue.  
Utilisez la colle Lasercut.  
Gebruik Lasercutlijm.

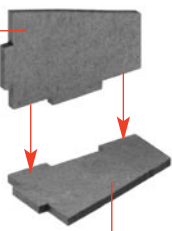

12/14

**R**

12/16  
Lasercut-Kleber verwenden.  
Use Lasercut glue.  
Utilisez la colle Lasercut.  
Gebruik Lasercutlijm.

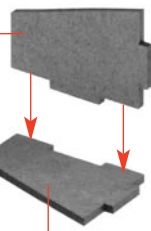

12/15

**S**

Lasercut-Kleber verwenden.  
Use Lasercut glue.  
Utilisez la colle Lasercut.  
Gebruik Lasercutlijm.

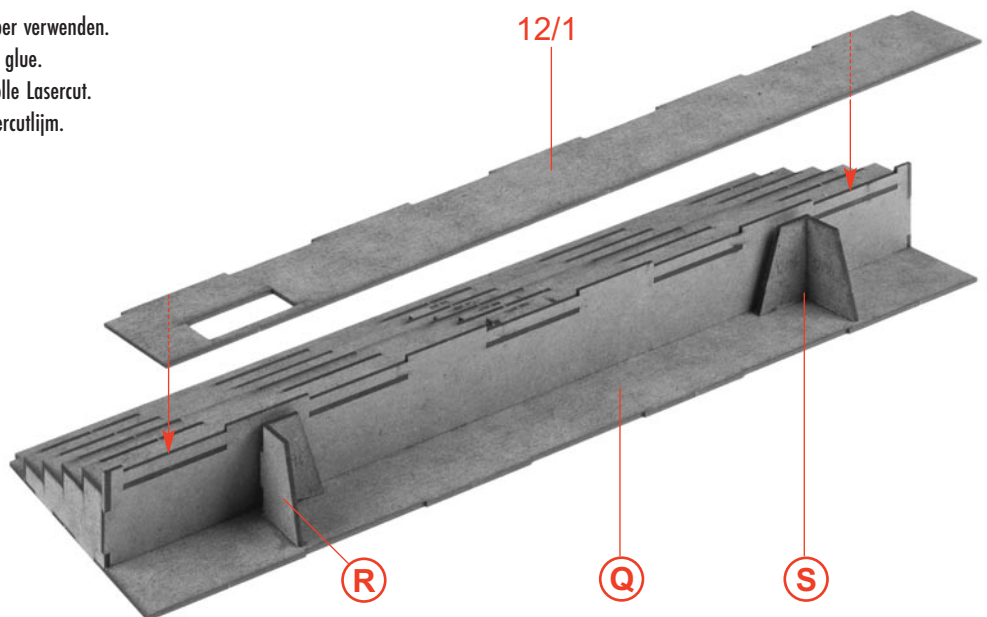

12/1

**T**

**R**

**Q**

**S**

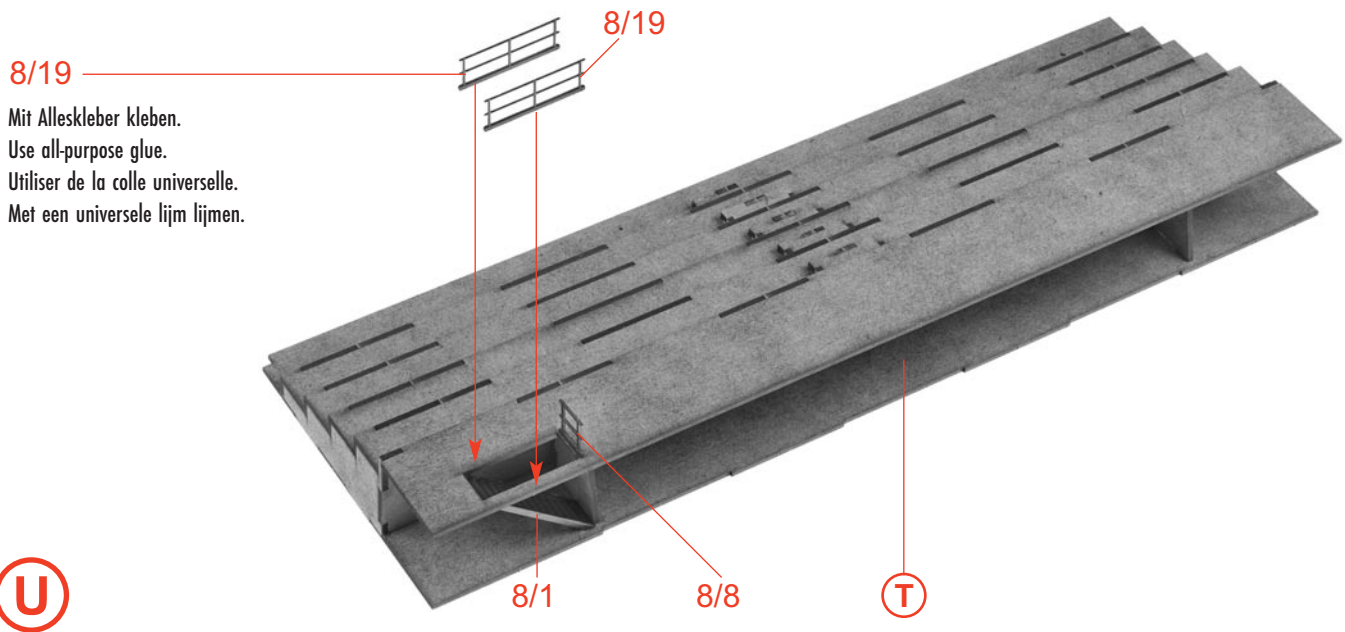

8/19  
 Mit Alleskleber kleben.  
 Use all-purpose glue.  
 Utiliser de la colle universelle.  
 Met een universele lijm lijmen.

Vorsichtig anritzen!  
 Scratch the line slightly!  
 Faire une pré-fente!  
 Op de aangegeven lijn inkepen!

Inhalt	Tüte 2
Contents	bag 2
Contenu	sachet 2
Inhoud	zakje 2

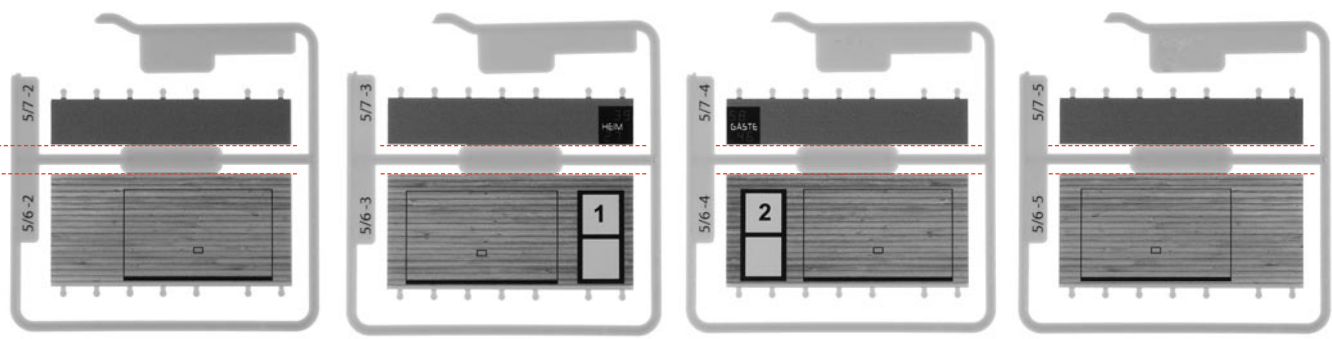

Nur wenig Kleber verwenden!  
 Use only a little glue!  
 Utilisez seulement un peu de colle!  
 Gebruik slechts een beetje lijm!

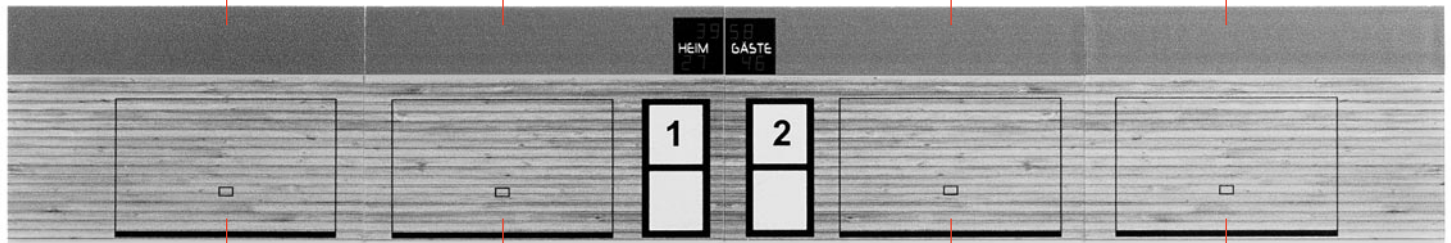

5/7-2                      5/7-3                      5/7-4                      5/7-5

5/6-2                      5/6-3                      5/6-4                      5/6-5

Mit Alleskleber kleben.  
 Use all-purpose glue.  
 Utiliser de la colle universelle.  
 Met een universele lijm lijmen.

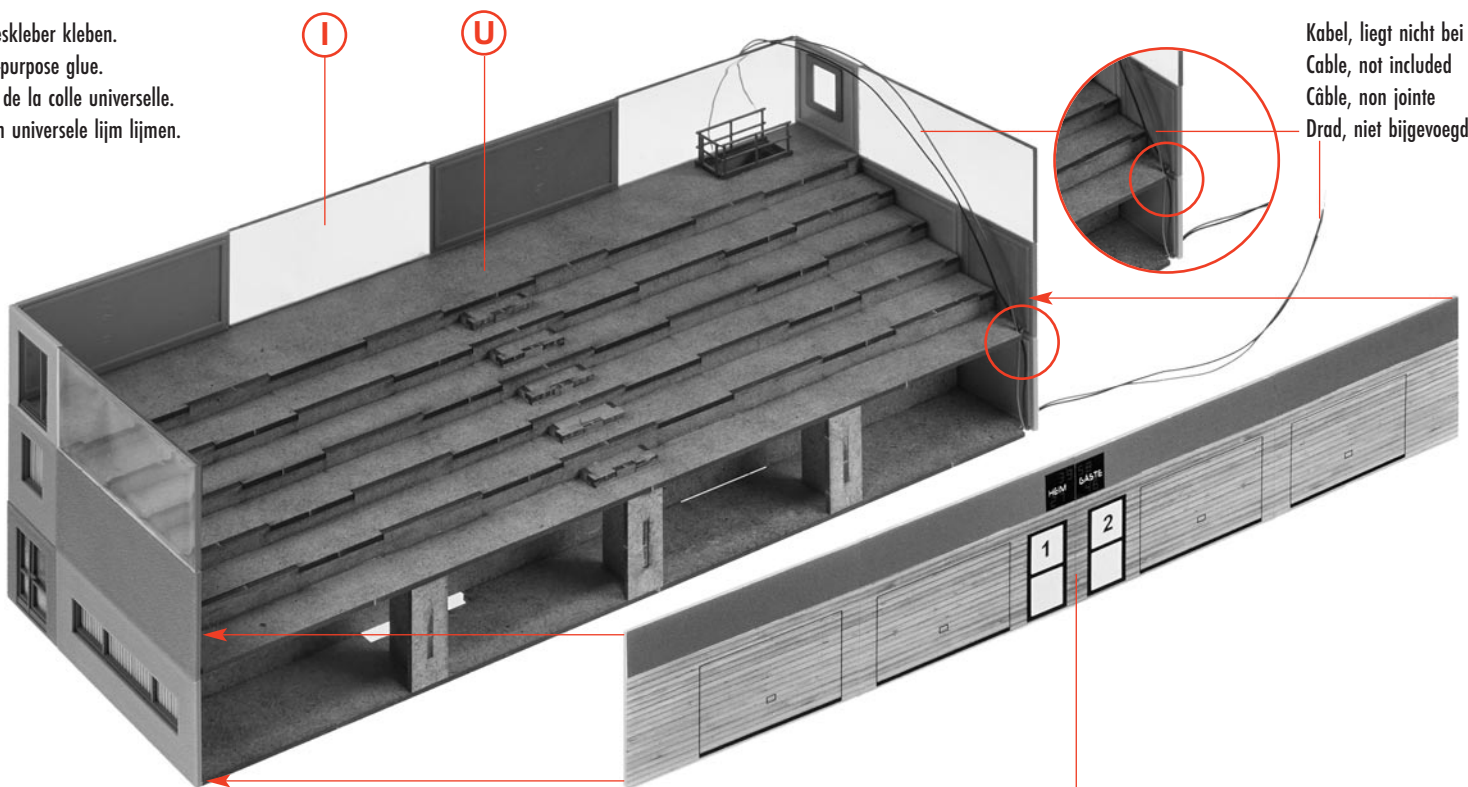

Kabel, liegt nicht bei  
 Cable, not included  
 Câble, non jointe  
 Drad, niet bijgevoegd

W

V

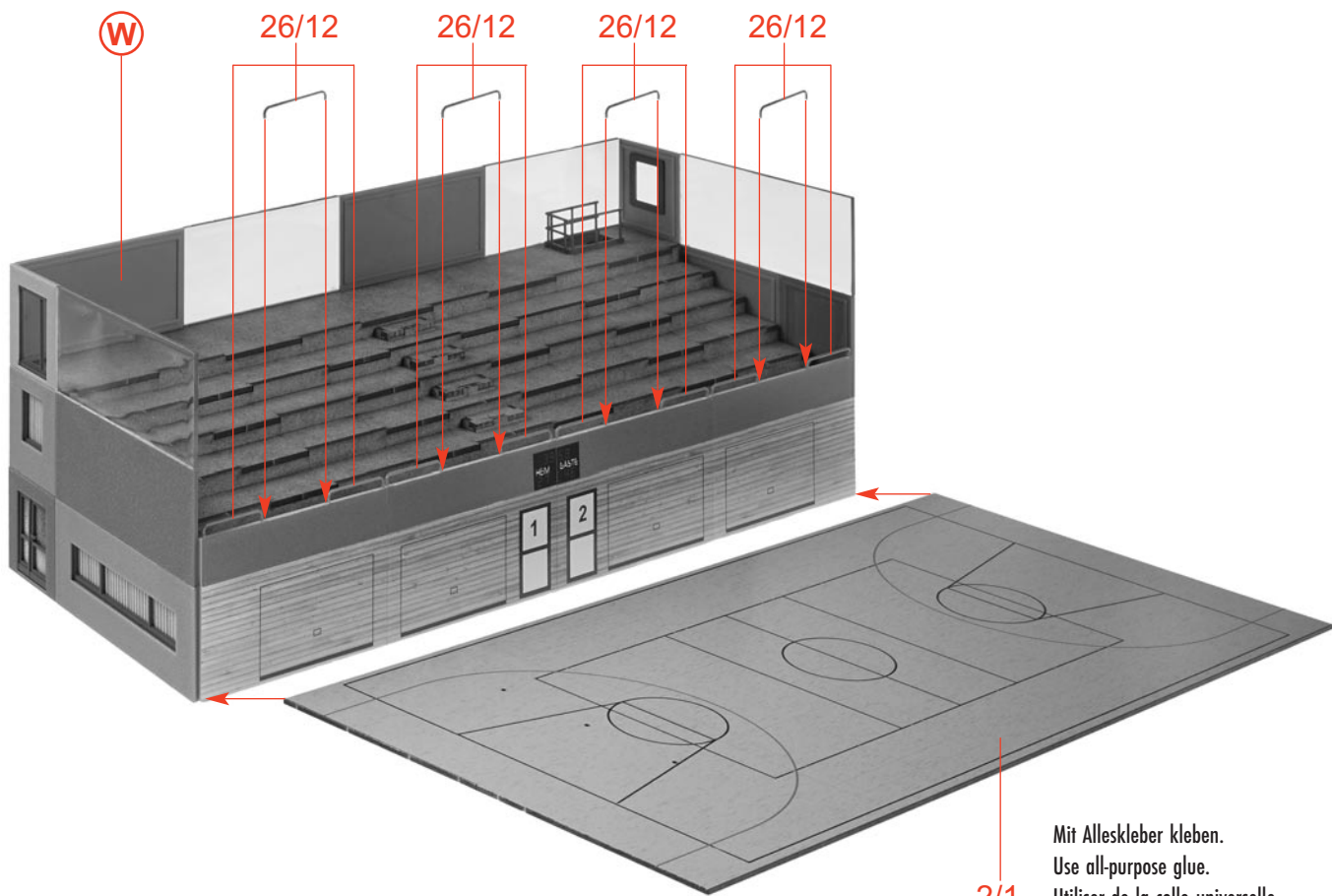

2/1  
 Mit Alleskleber kleben.  
 Use all-purpose glue.  
 Utiliser de la colle universelle.  
 Met een universele lijm lijmen.

**a**

Nur wenig Kleber verwenden!  
 Use only a little glue!  
 Utilisez seulement un peu de colle!  
 Gebruik slechts een beetje lijm!

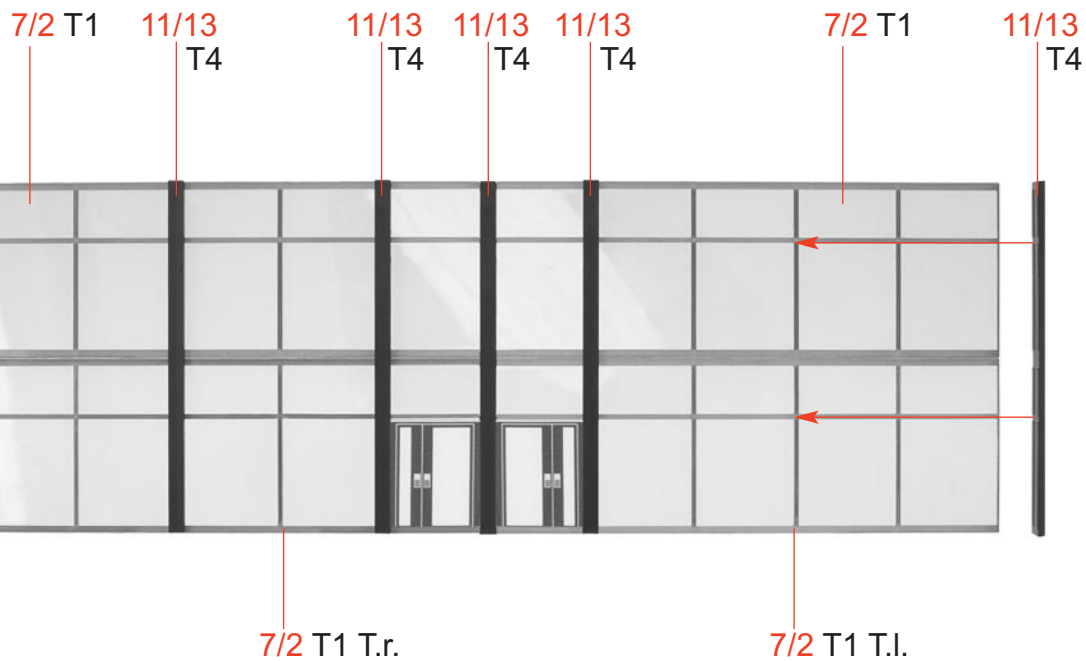

Rahmen vorne!  
 Frame in front!  
 Cadre devant !  
 Frame vooraan!

**b**

Nur wenig Kleber verwenden!  
 Use only a little glue!  
 Utilisez seulement un peu de colle!  
 Gebruik slechts een beetje lijm!

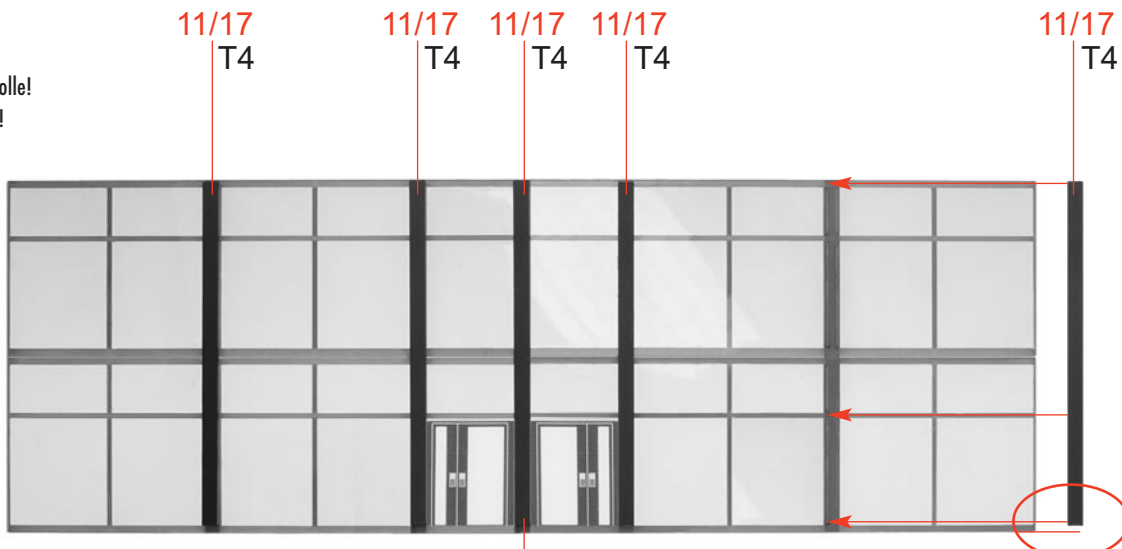

**c**

**b**



Nur wenig Kleber verwenden!  
Use only a little glue!  
Utilisez seulement un peu de colle!  
Gebruik slechts een beetje lijm!

11/13 T4 7/2 T1 11/13 T4

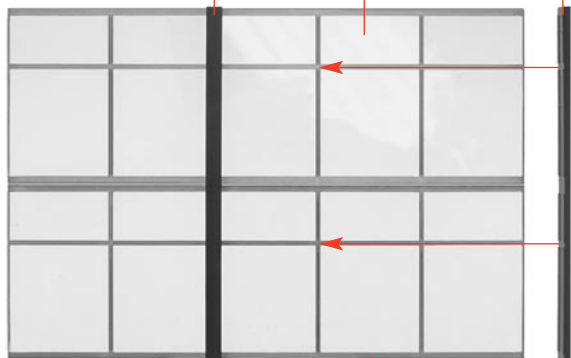

Rahmen vorne!  
Frame in front!  
Cadre devant !  
Frame vooraan!

**d** 2 x

7/2 T1

Nur wenig Kleber verwenden!  
Use only a little glue!  
Utilisez seulement un peu de colle!  
Gebruik slechts een beetje lijm!

11/17 T4 11/17 T4

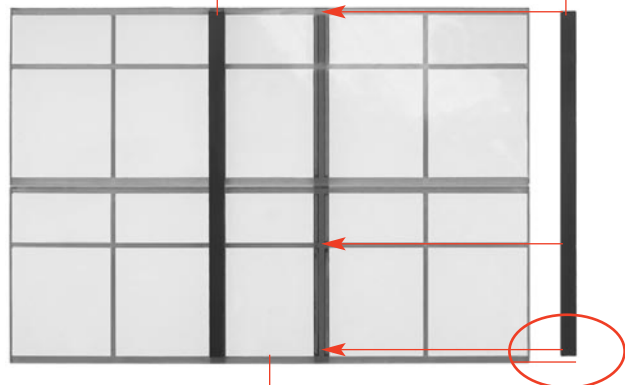

**e** 2 x

**d**

11/18 T4

**c**

11/18 T4

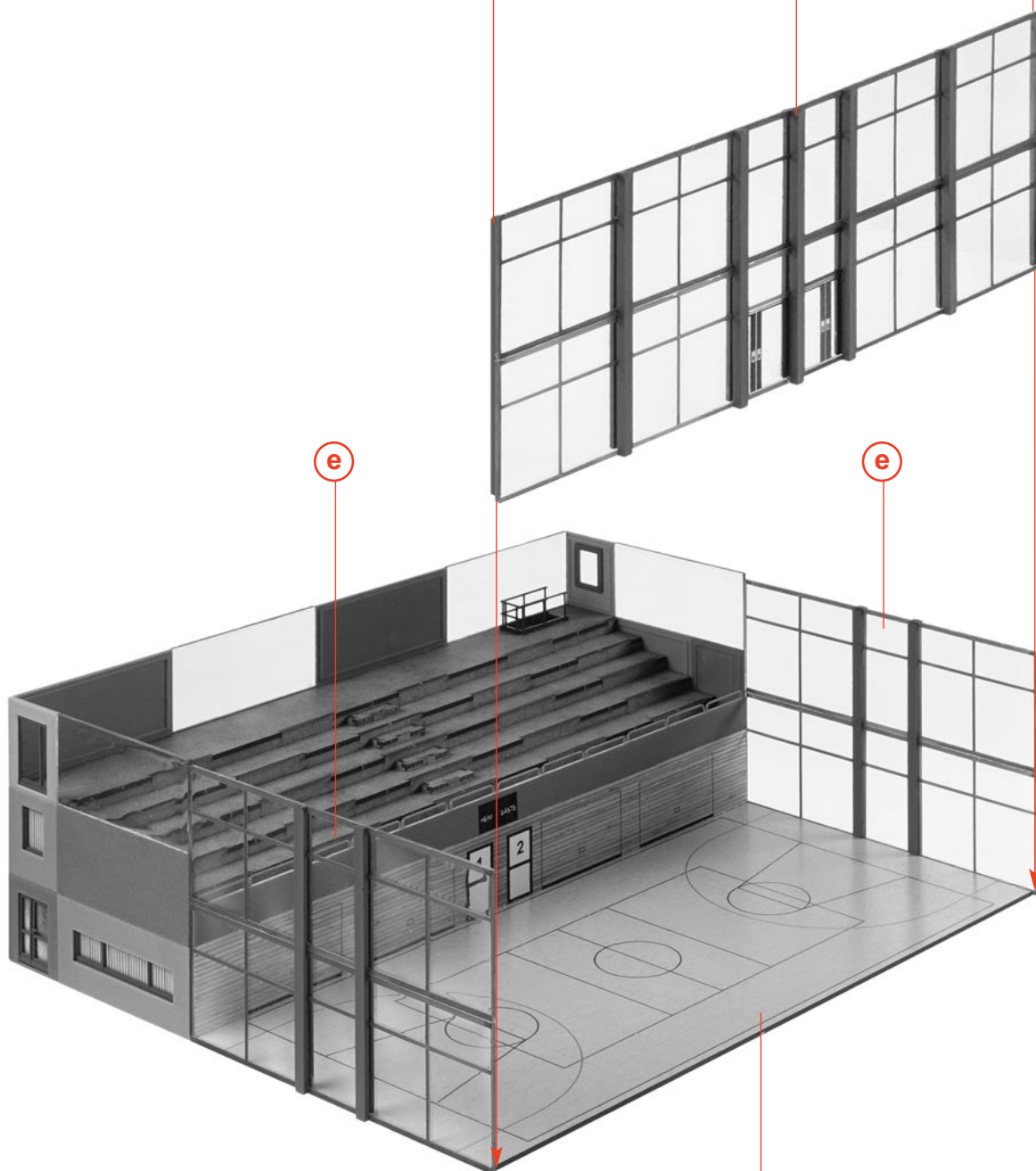

**f**

**a**

Mit Alleskleber kleben.  
Use all-purpose glue.  
Utiliser de la colle universelle.  
Met een universele lijm lijmen.

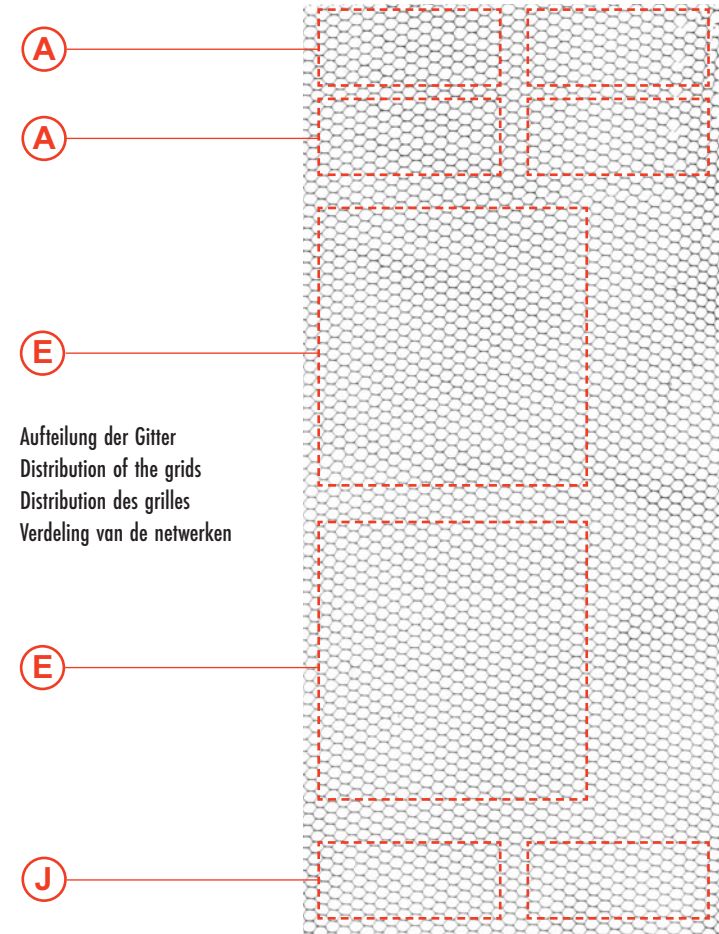
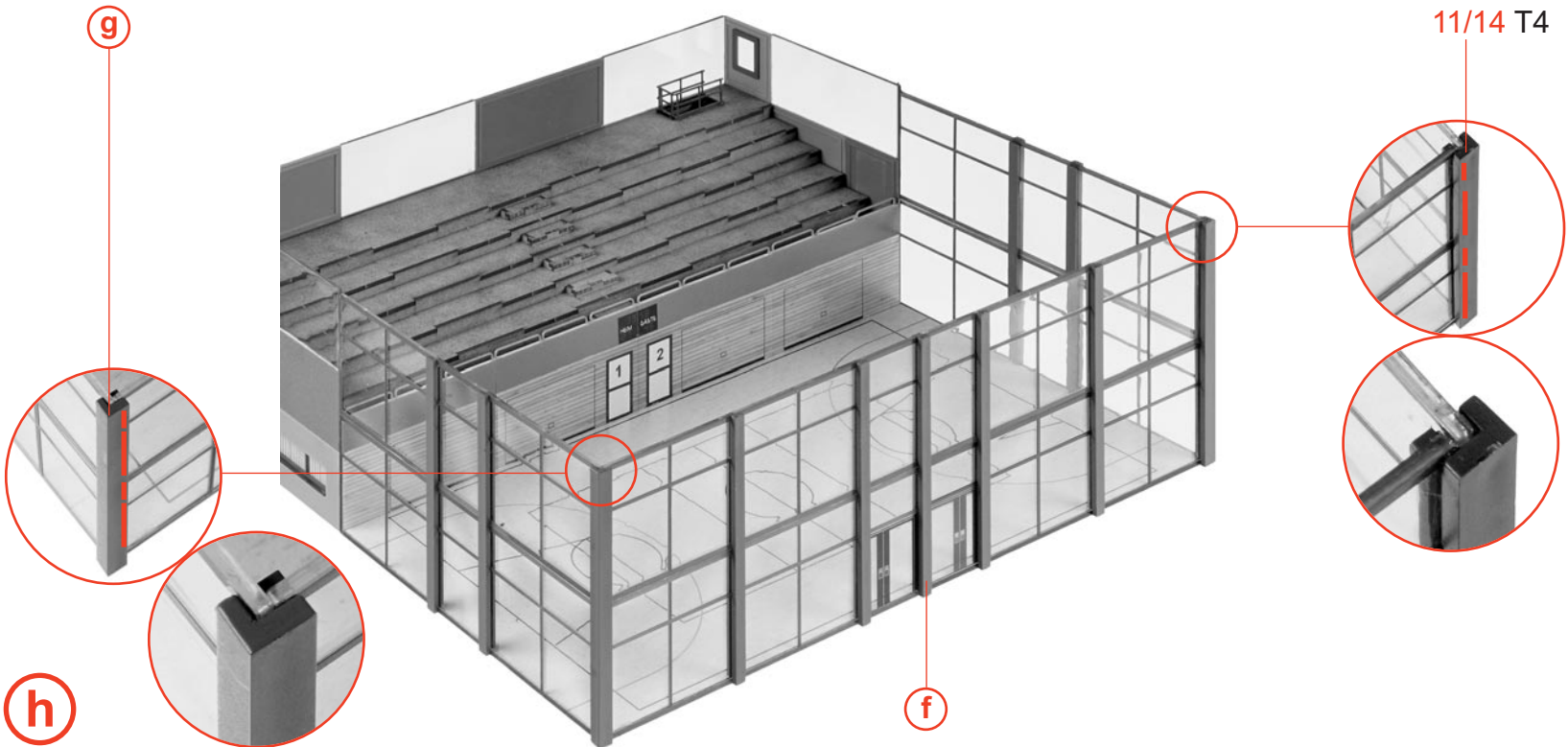

Aufteilung der Gitter  
Distribution of the grids  
Distribution des grilles  
Verdeling van de netwerken

Bemalungshinweis, schwarz/ Weiss  
Painting instruction, black/ white  
Instruction de coloration, noir/ blanc  
Schilderadviezen, zwart/ wit

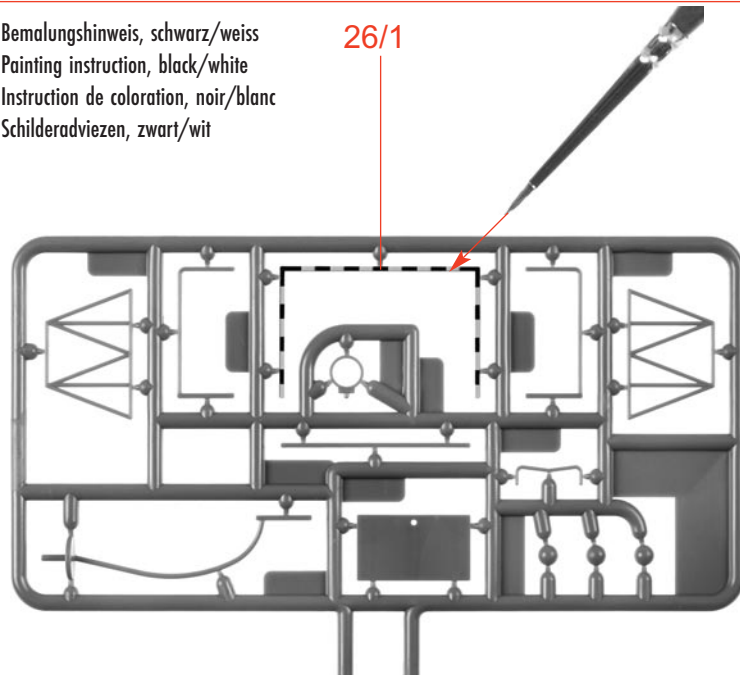

Gitter  
Grill  
Grille  
Tralie

**(A)** 2 x

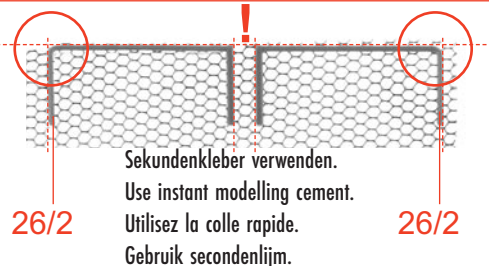

Sekundenkleber verwenden.  
Use instant modelling cement.  
Utilisez la colle rapide.  
Gebruik secondenlijm.

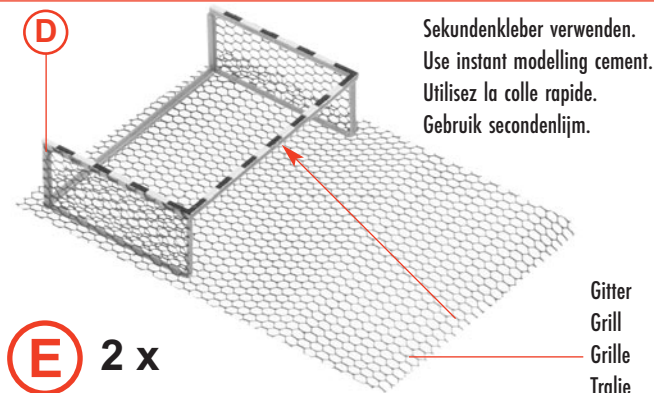
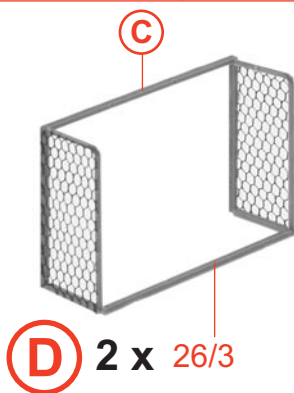
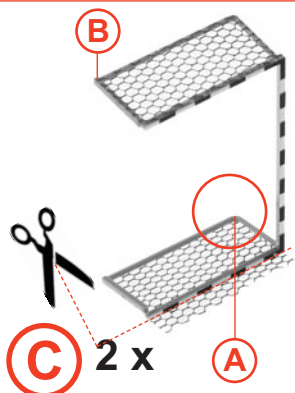
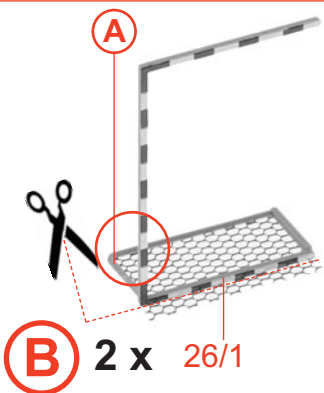

Gitter  
Grill  
Grille  
Tralie

Sekundenkleber verwenden.  
Use instant modelling cement.  
Utilisez la colle rapide.  
Gebruik secondenlijm.

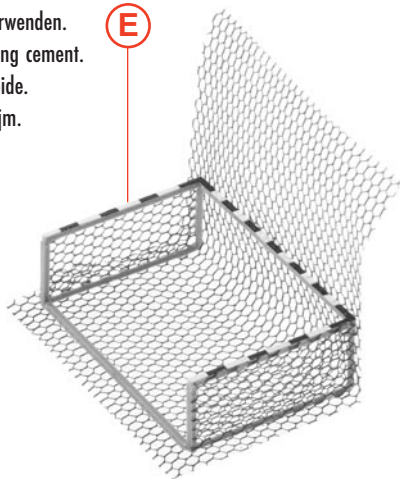

**F** 2 x

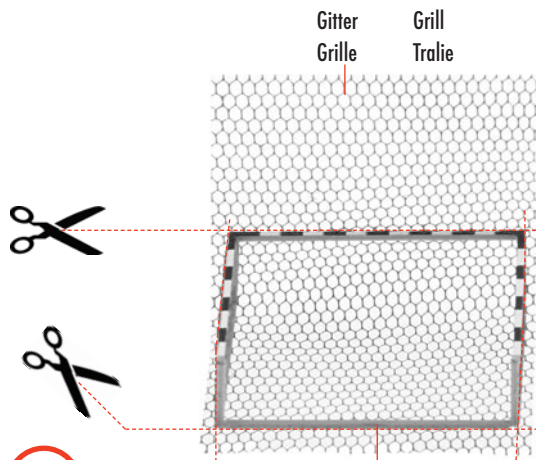

**G** 2 x

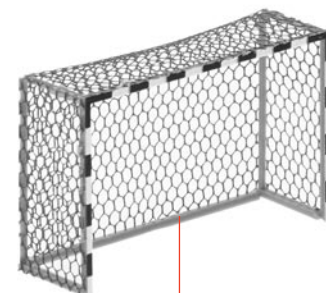

**H** 2 x

**G**

Deco 7

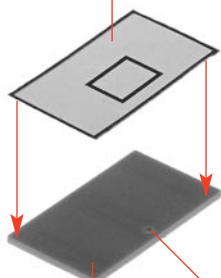

26/6

**I** 2 x  
Loch durchstechen  
Pierce hole through  
Piquez le trou  
Gat doorsteken

**I** 26/9

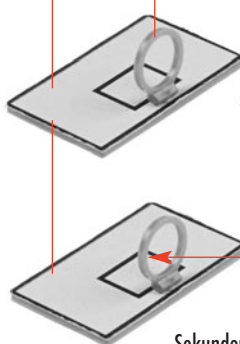

**J** 2 x

Sekundenkleber verwenden.  
Use instant modelling cement.  
Utilisez la colle rapide.  
Gebruik secondenlijm.

Gitter abziehen  
Pull off grill  
Enlever le grille  
Tralie klaarspelen

Deco 8 17 x 7 mm



**K** 2 x

**J**

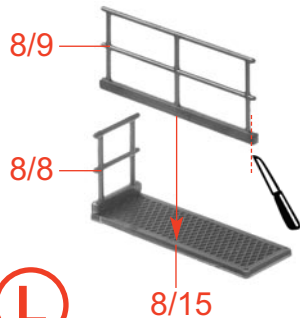

**L**

Art. Nr. 180354:  
Turnhalleneinrichtung,  
liegt nicht bei.  
Sports hall interior equipment,  
not included.  
Aménagement de salle de sports,  
non jointe.  
Sporthal interieur,  
niet bijgevoegd.

26/5 **K** 26/5

**H**

26/8

**H**

26/5 **K** 26/5

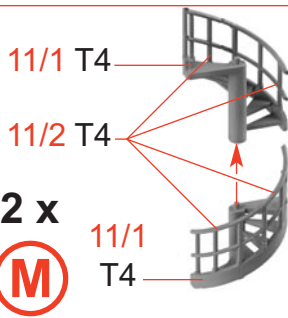

**M** 2 x

11/1 T4

**M**

**M**

**N**

**O** h

4/13

**N**

**L**

8/13

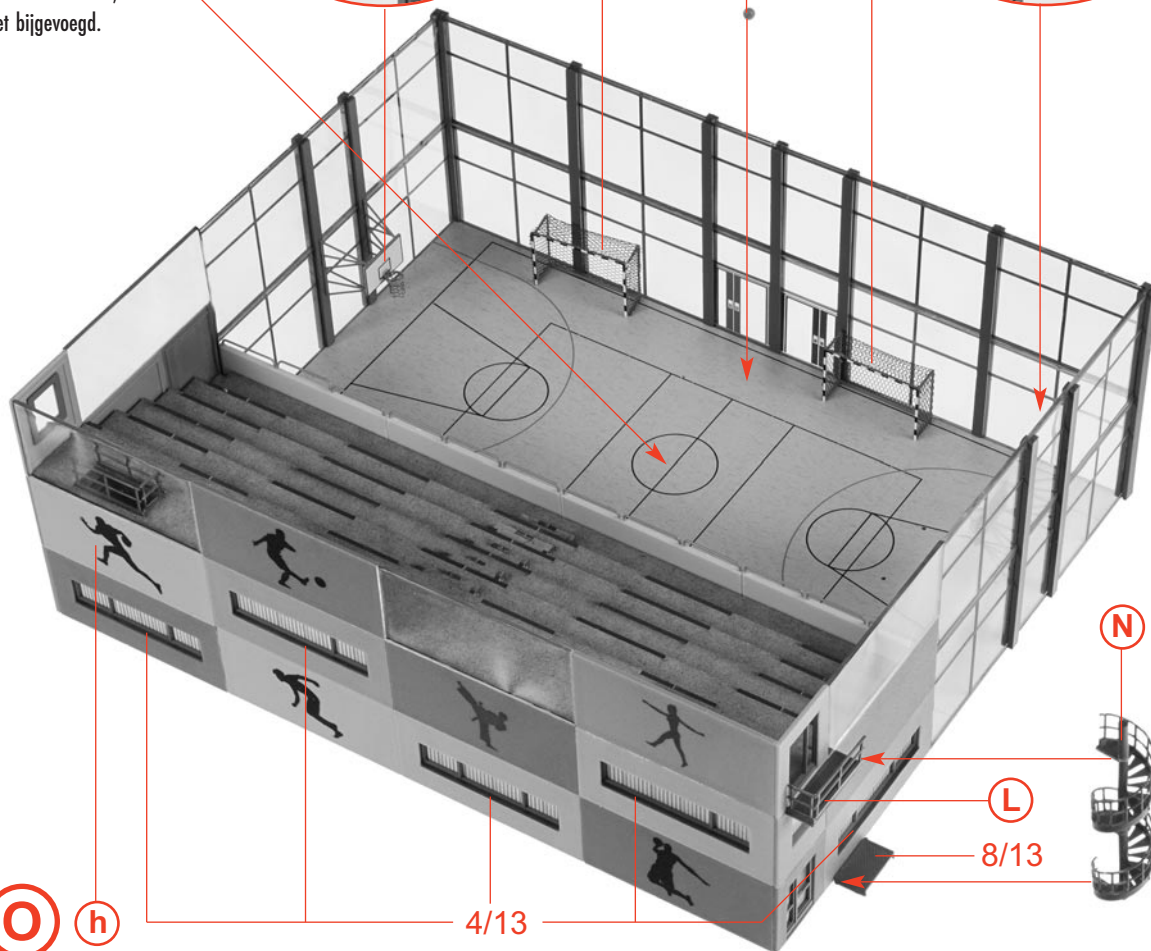

12

Lasercut-Kleber verwenden.  
Use Lasercut glue.  
Utilisez la colle Lasercut.  
Gebruik Lasercutlijm.

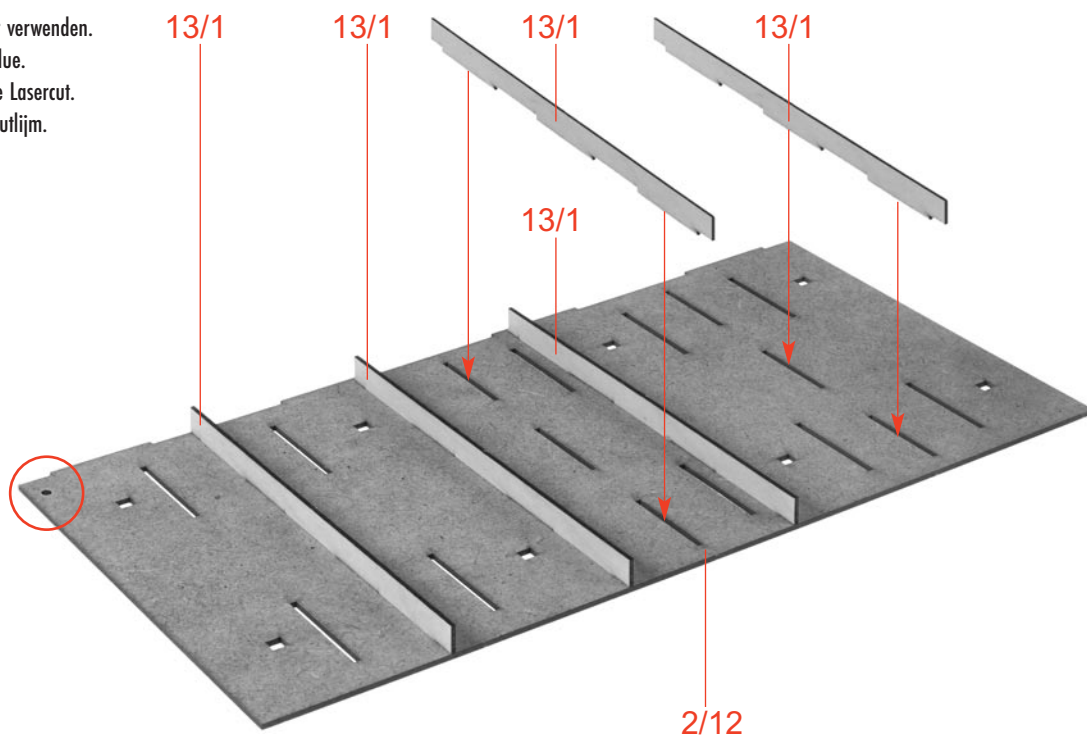

P

Lasercut-Kleber verwenden.  
Use Lasercut glue.  
Utilisez la colle Lasercut.  
Gebruik Lasercutlijm.

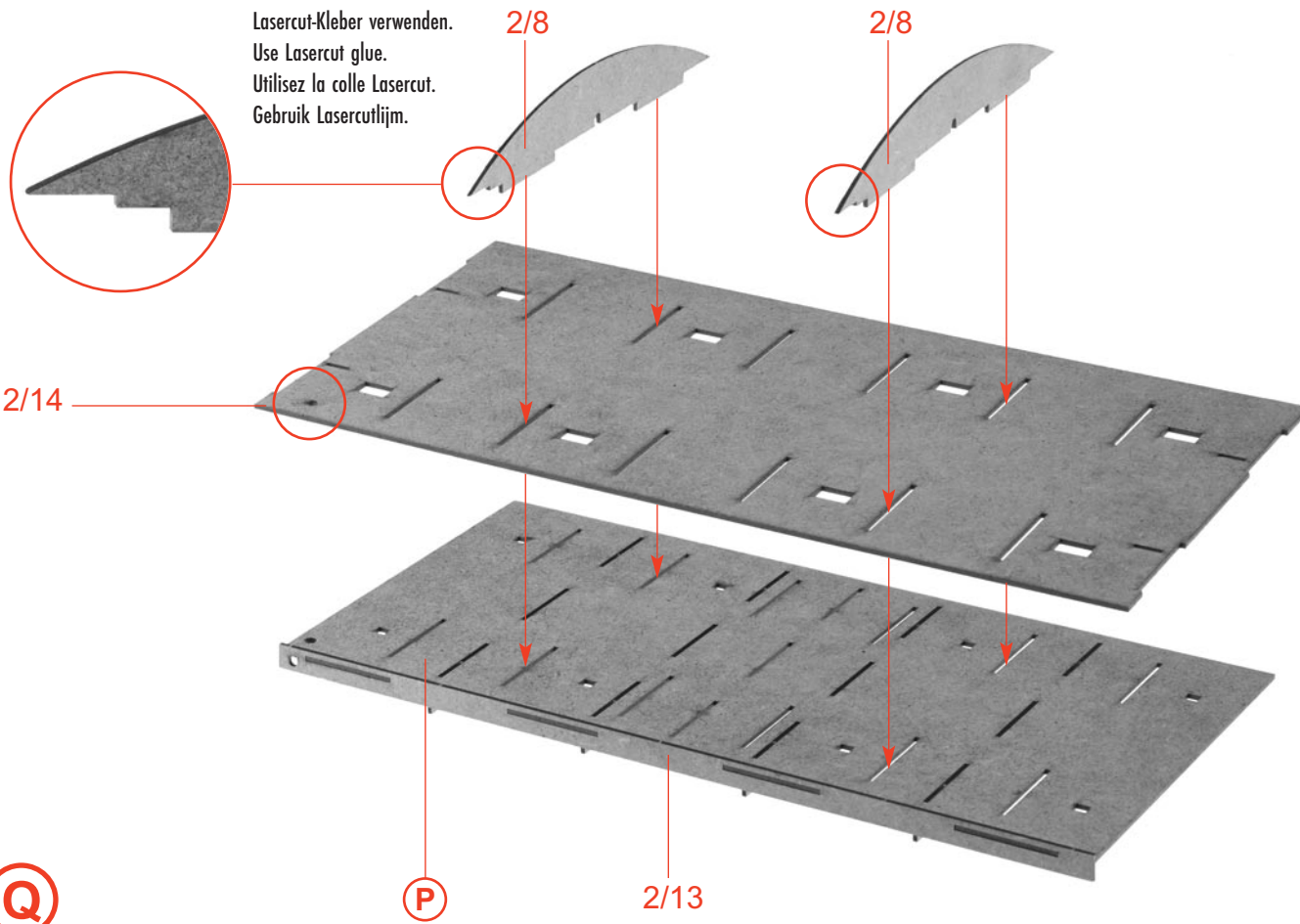

Q

Lasercut-Kleber verwenden.  
Use Lasercut glue.  
Utilisez la colle Lasercut.  
Gebruik Lasercutlijm.

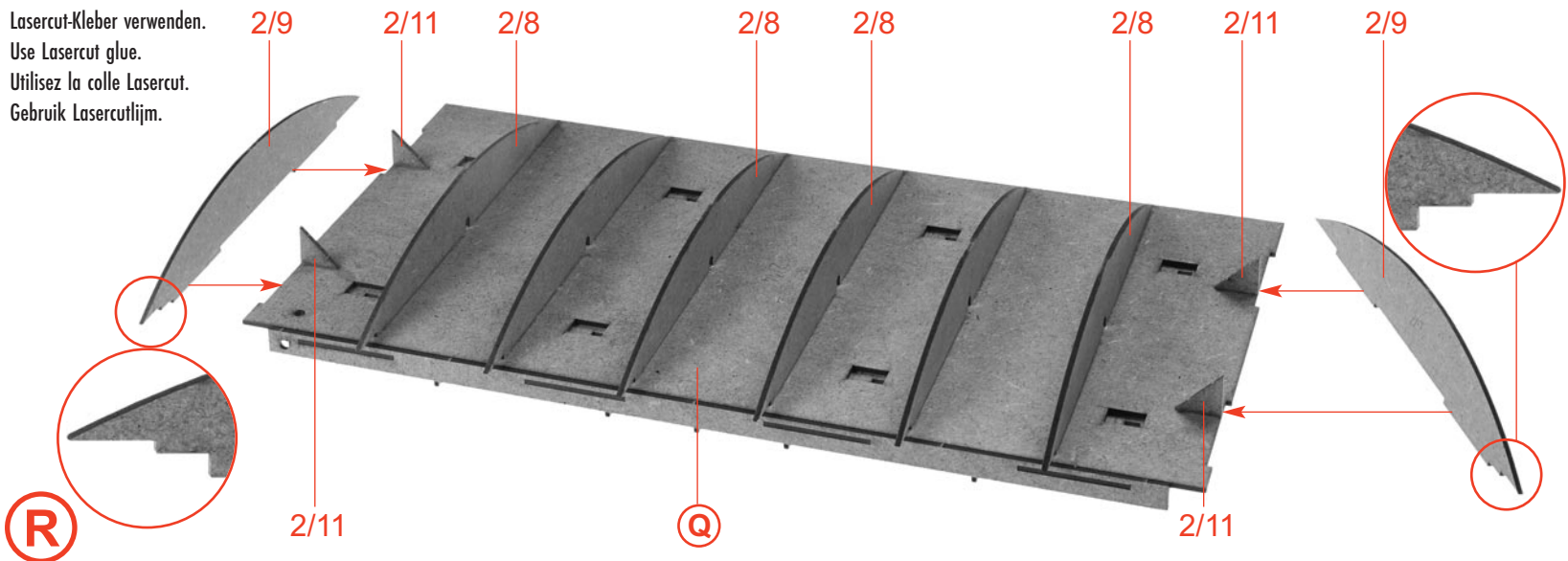

R

Klebestreifen  
Adhesive tape  
Ruban adhésif  
Plakband

Klebestreifen  
Adhesive tape  
Ruban adhésif  
Plakband

2 x Art. Nr. 180653:  
Beleuchtung, liegt nicht bei  
Illumination, not included  
Eclairage, non jointe  
Verlichting, niet bijgevoegd

Klebestreifen  
Adhesive tape  
Ruban adhésif  
Plakband

Bitte auf Polung achten!  
See to it that poling is correct!  
Veiller à respecter la polarité!  
Let op de juiste polariteit!

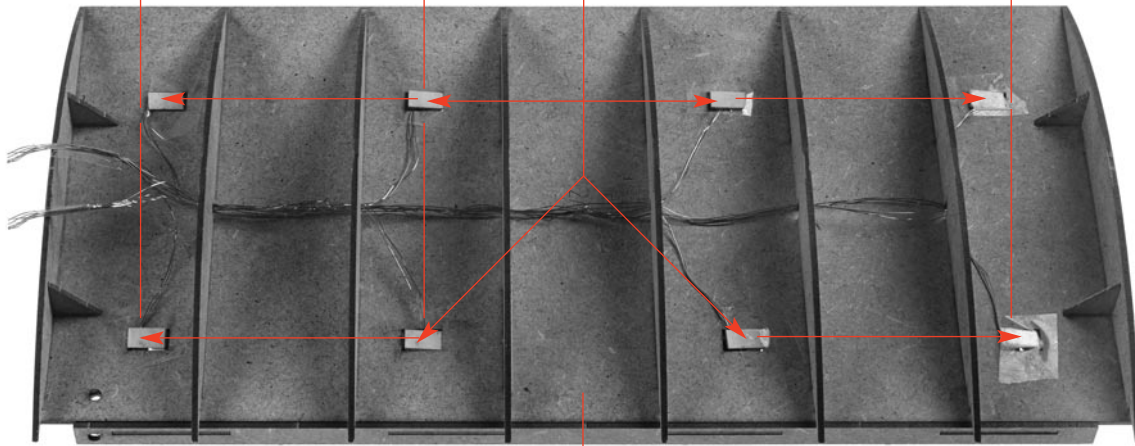

S

R

15/1

Vorsichtig biegen!  
Bend cautiously!  
Plier prudemment!  
Voorzichtig buigen!

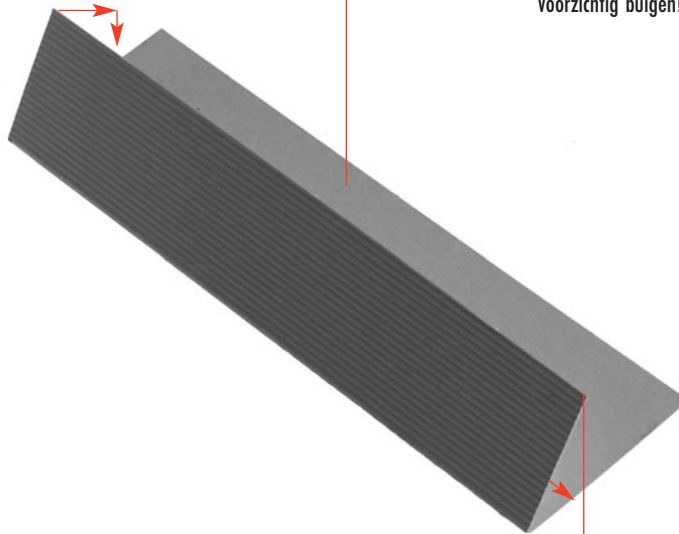

Lasercut-Kleber verwenden.  
Use Lasercut glue.  
Utilisez la colle Lasercut.  
Gebruik Lasercutlijm.

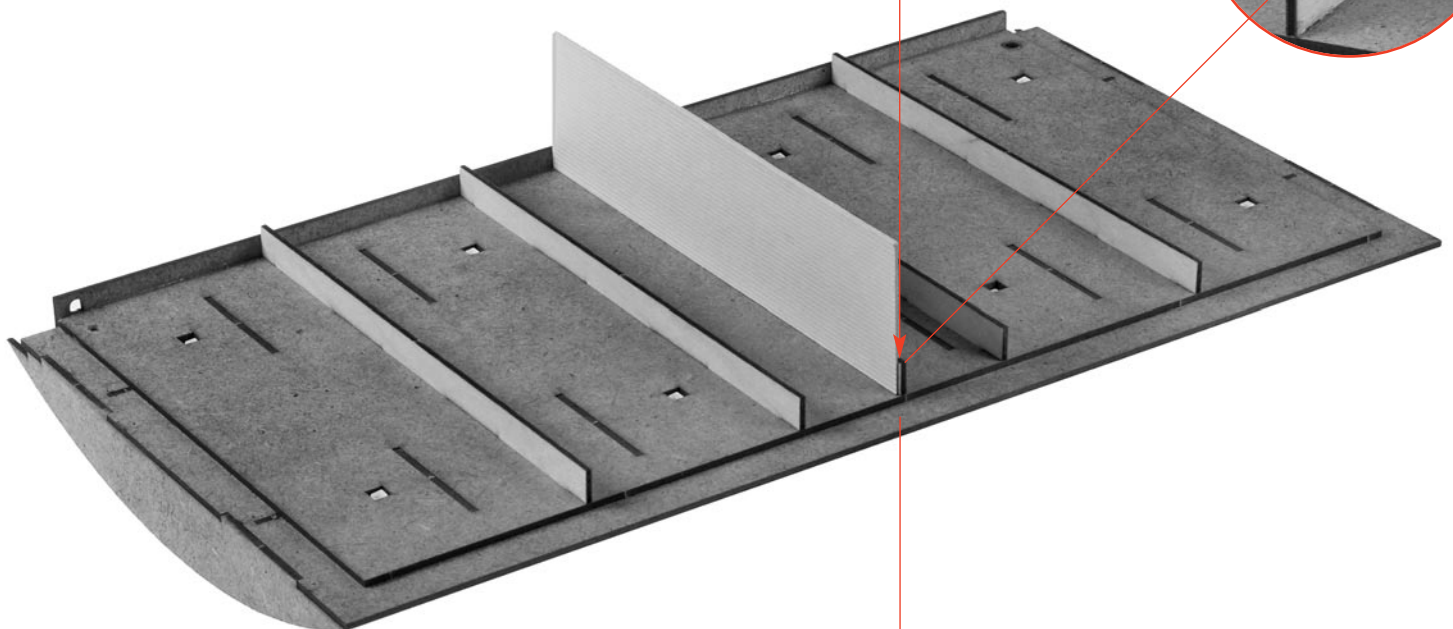

T

S

14

4/4 1/17

1/7-H T3  
hell bright  
brillant helder  
dunkel dark  
sombre donker

5/1-P T3  
! Fensterfolie  
Window foil  
Feuillet transparent  
Vensterfolie

NORDWEST-HALLE 1/17

1/7-H IV T3  
dunkel dark  
sombre donker

1/4-G T3  
hell bright  
brillant helder

5/7-1 T2

5/6-1 T2

Rahmen vorne!  
Frame in front!  
Cadre devant!  
Frame vooraan!

Deco 1

NORDWEST-HALLE

2/2

Mit Alleskleber kleben.  
Use all-purpose glue.  
Utiliser de la colle universelle.  
Met een universele lijm lijmen.

NORDWEST-HALLE

Rahmen vorne!  
Frame in front!  
Cadre devant!  
Frame vooraan!

Mit Alleskleber kleben.  
Use all-purpose glue.  
Utiliser de la colle universelle.  
Met een universele lijm lijmen.

Mit Alleskleber kleben.  
Use all-purpose glue.  
Utiliser de la colle universelle.  
Met een universele lijm lijmen.

T nicht kleben  
do not glue  
ne pas coller  
niet lijmen

Lasercut-Kleber verwenden.  
Use Lasercut glue.  
Utilisez la colle Lasercut.  
Gebruik Lasercutlijm.

Nur an dieser Stelle kleben.  
Only apply glue to this point.  
Coller exclusivement cet emplacement.  
Alleen op deze plaats lijmen.

Z 2/10 Y O 2/7

**a** M 1:1



**b** M 1:1

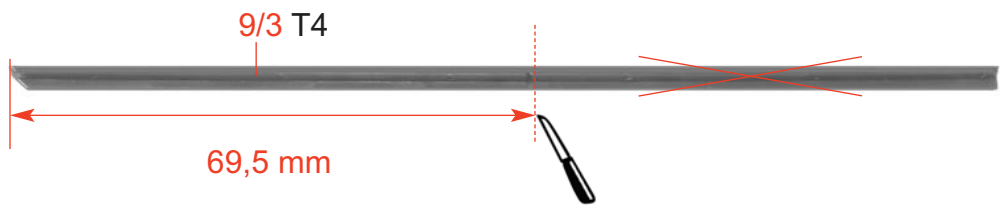

**a** Mit Alleskleber kleben.  
Use all-purpose glue.  
Utiliser de la colle universelle.  
Met een universele lijm lijmen.

9/3 T4

9/6 T4

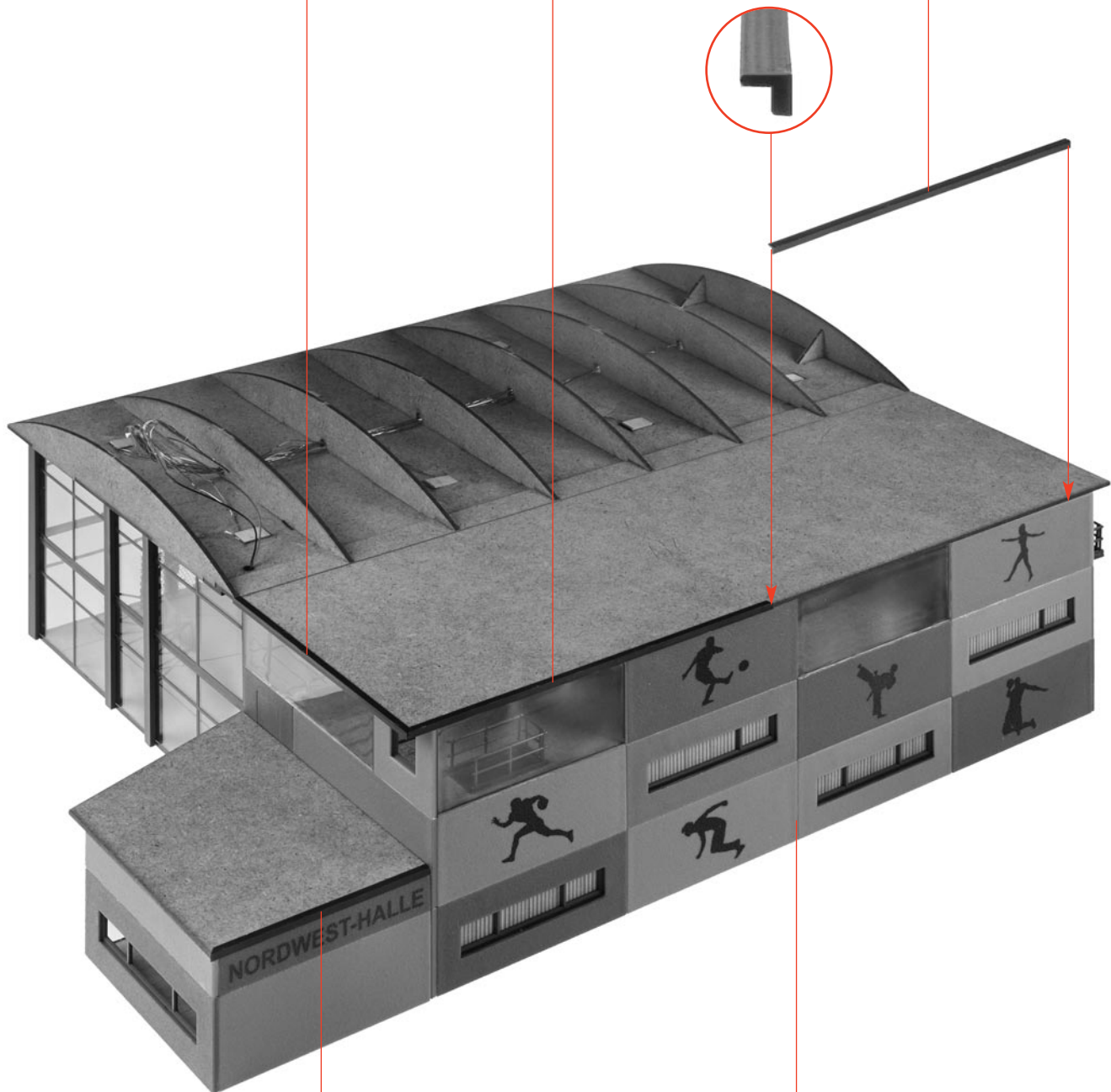

**c**

**b**

**z**

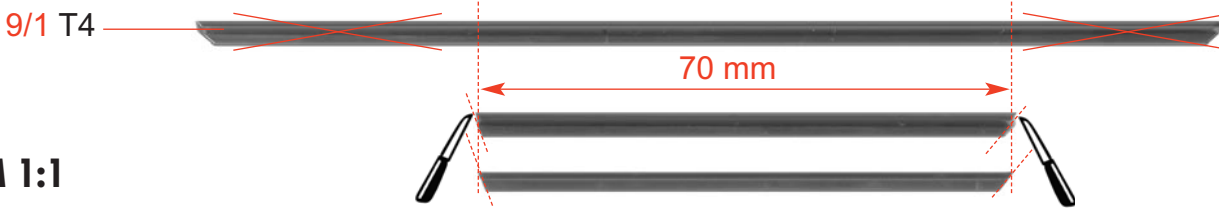
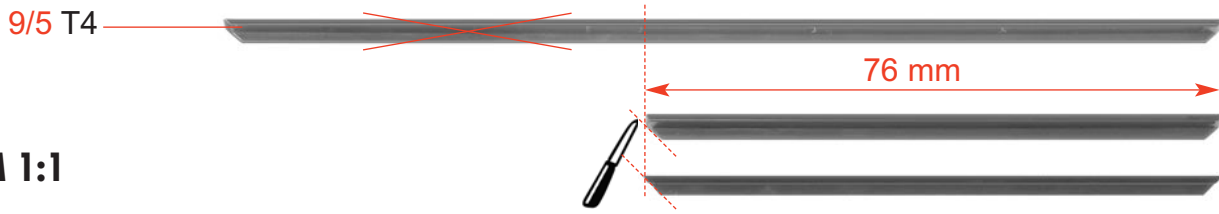

Lasercut-Kleber verwenden.  
Use Lasercut glue.  
Utilisez la colle Lasercut.  
Gebruik Lasercutlijm.

14/1

**(d)** a

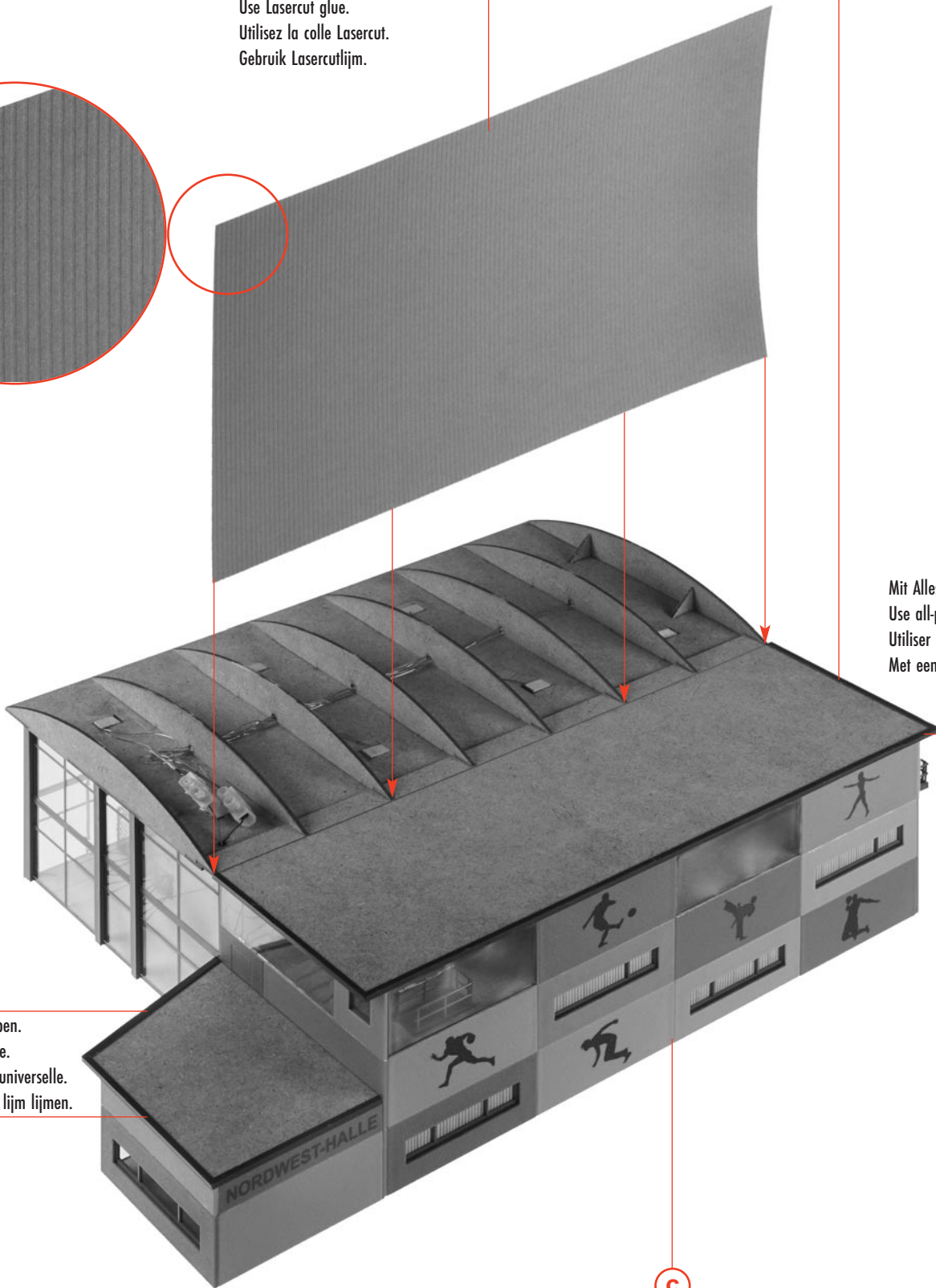
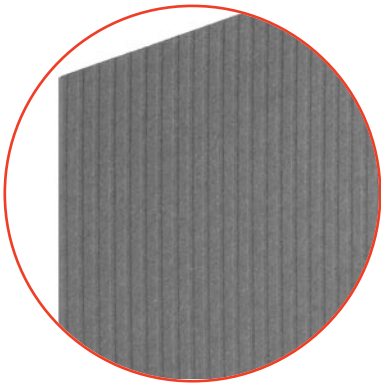

Mit Alleskleber kleben.  
Use all-purpose glue.  
Utiliser de la colle universelle.  
Met een universele lijm lijmen.

**(d)** b

**(f)** Mit Alleskleber kleben.  
Use all-purpose glue.  
Utiliser de la colle universelle.

**(e)** Met een universele lijm lijmen.

**(g)**

**(c)**



Art. Nr. 170659:  
 Colofix-Flex, liegt nicht bei  
 Colofix-Flex, not included  
 Colofix-Flex, non jointe  
 Colofix-Flex, niet bijgevoegd

14/2

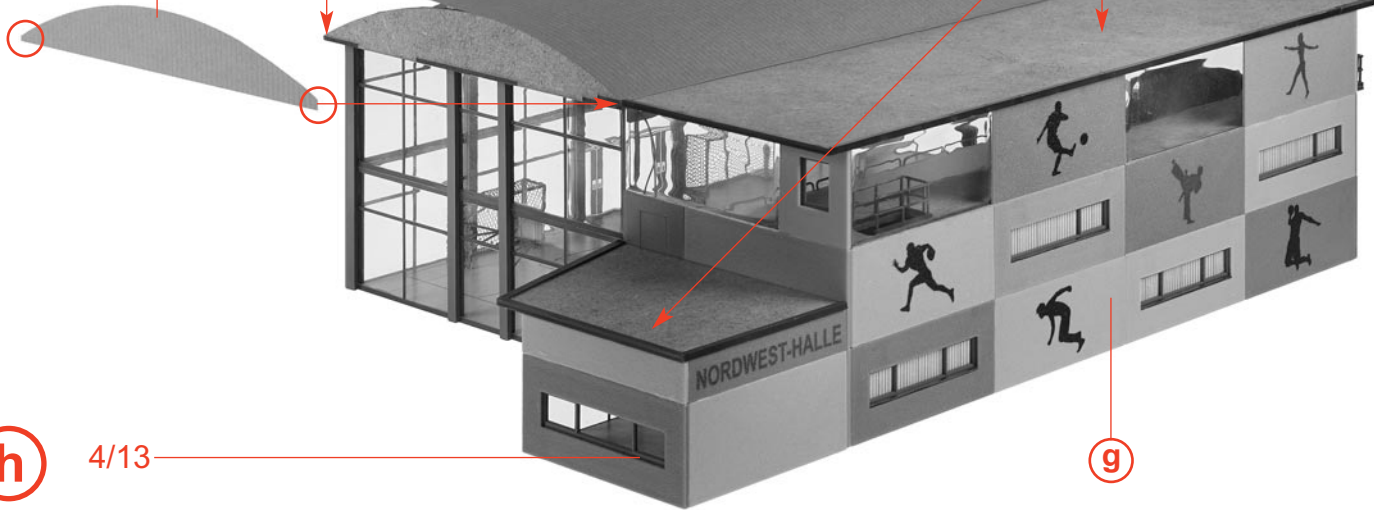

h

4/13

g

<b>Inhalt</b>	Tüte	<b>Contents</b>	bag
<b>Contenu</b>	sachet	<b>Inhoud</b>	zakje

14/3

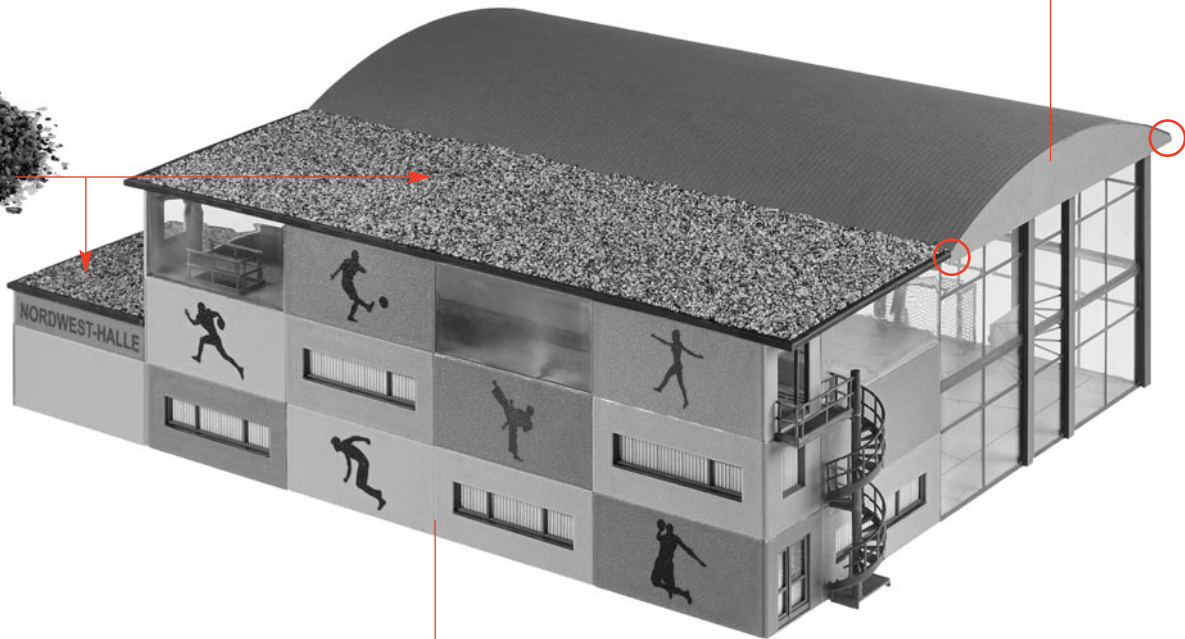

i

h

**ACHTUNG!**  
 Dach beschweren um Verzug zu vermeiden.  
 Gut trocknen lassen (24 h).

**ATTENTION!**  
 Complain to roof to avoid delay.  
 Allow to dry well (24 h).

**ATTENTION !**  
 Se plaindre au toit pour éviter les retards.  
 Laisser bien sécher (24 h).

**LET OP!**  
 Klap tegen het dak om vertraging te voorkomen.  
 Laat goed drogen (24 uur).

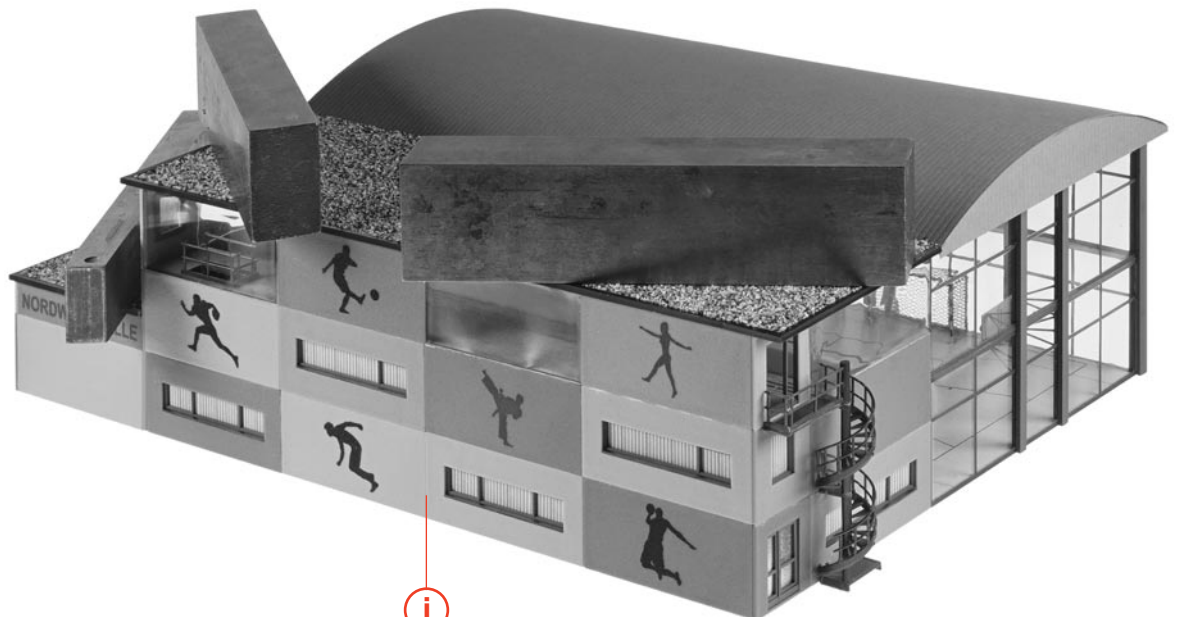

j

i

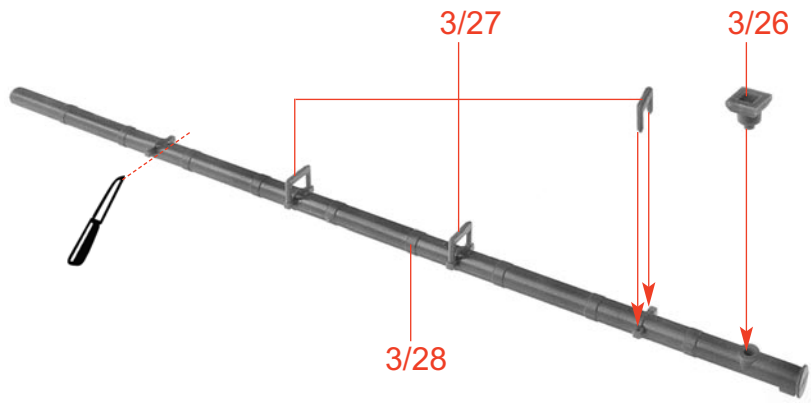

**k**

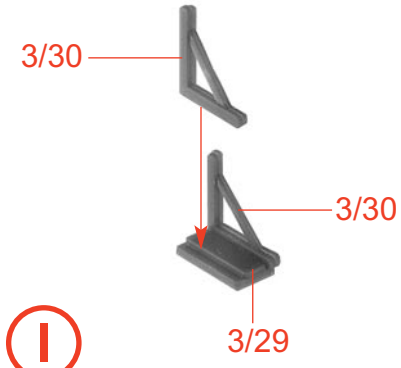

**l**

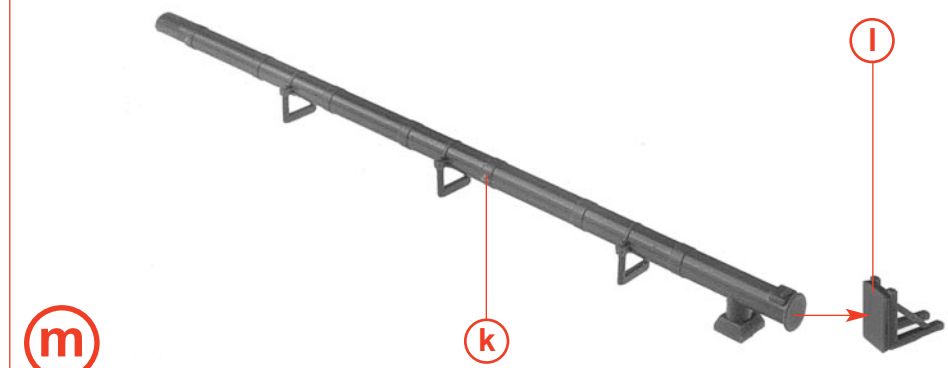

**m**

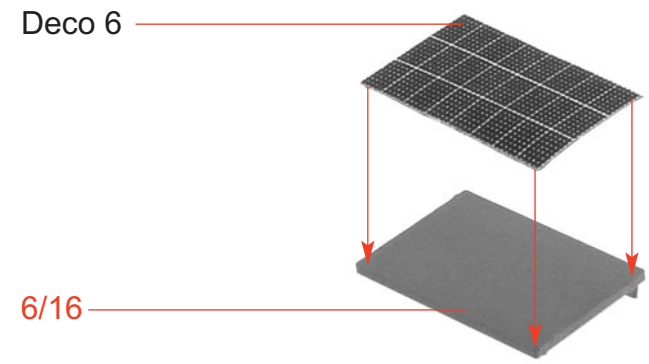

**n** 4 x

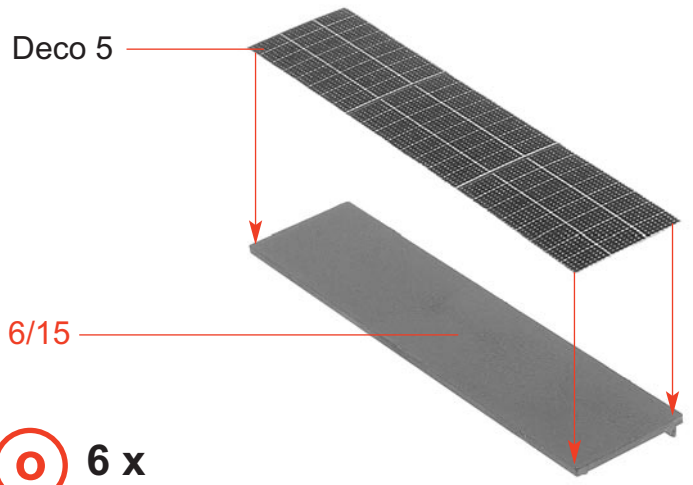

**o** 6 x

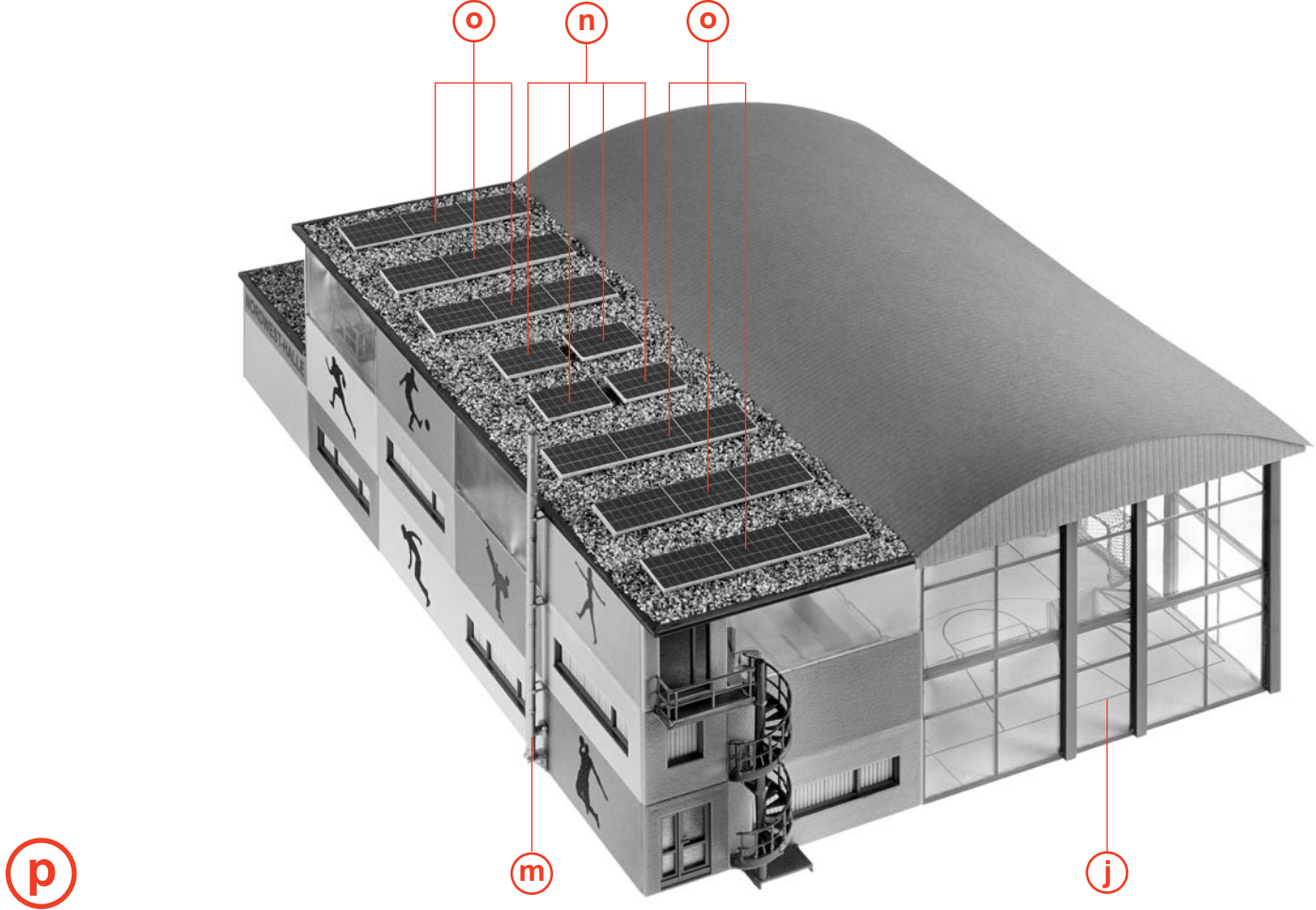

**p**

Art. Nr. 180354:  
 Turnhalleneinrichtung, liegt nicht bei.  
 Sports hall interior equipment, not included.  
 Aménagement de salle de sports, non jointe.  
 Sporthal interieur, niet bijgevoegd.

p

q

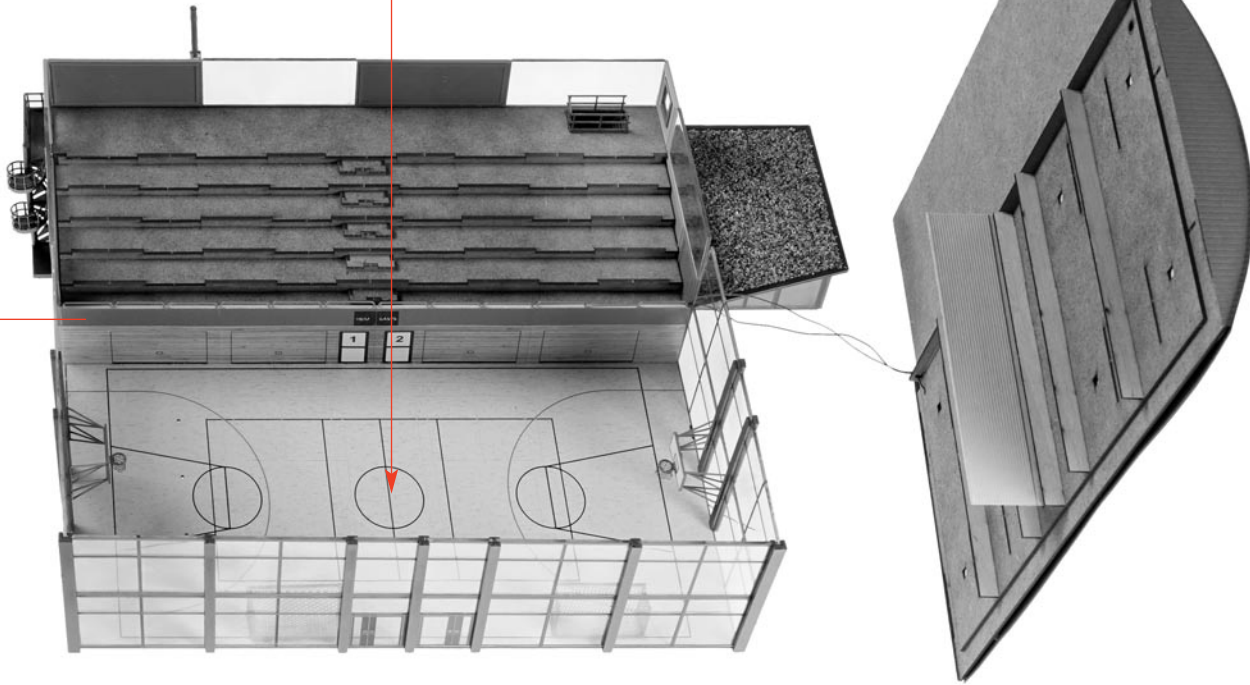

Art. Nr. 180354:  
 Turnhalleneinrichtung, liegt nicht bei.  
 Sports hall interior equipment, not included.  
 Aménagement de salle de sports, non jointe.  
 Sporthal interieur, niet bijgevoegd.

q

r

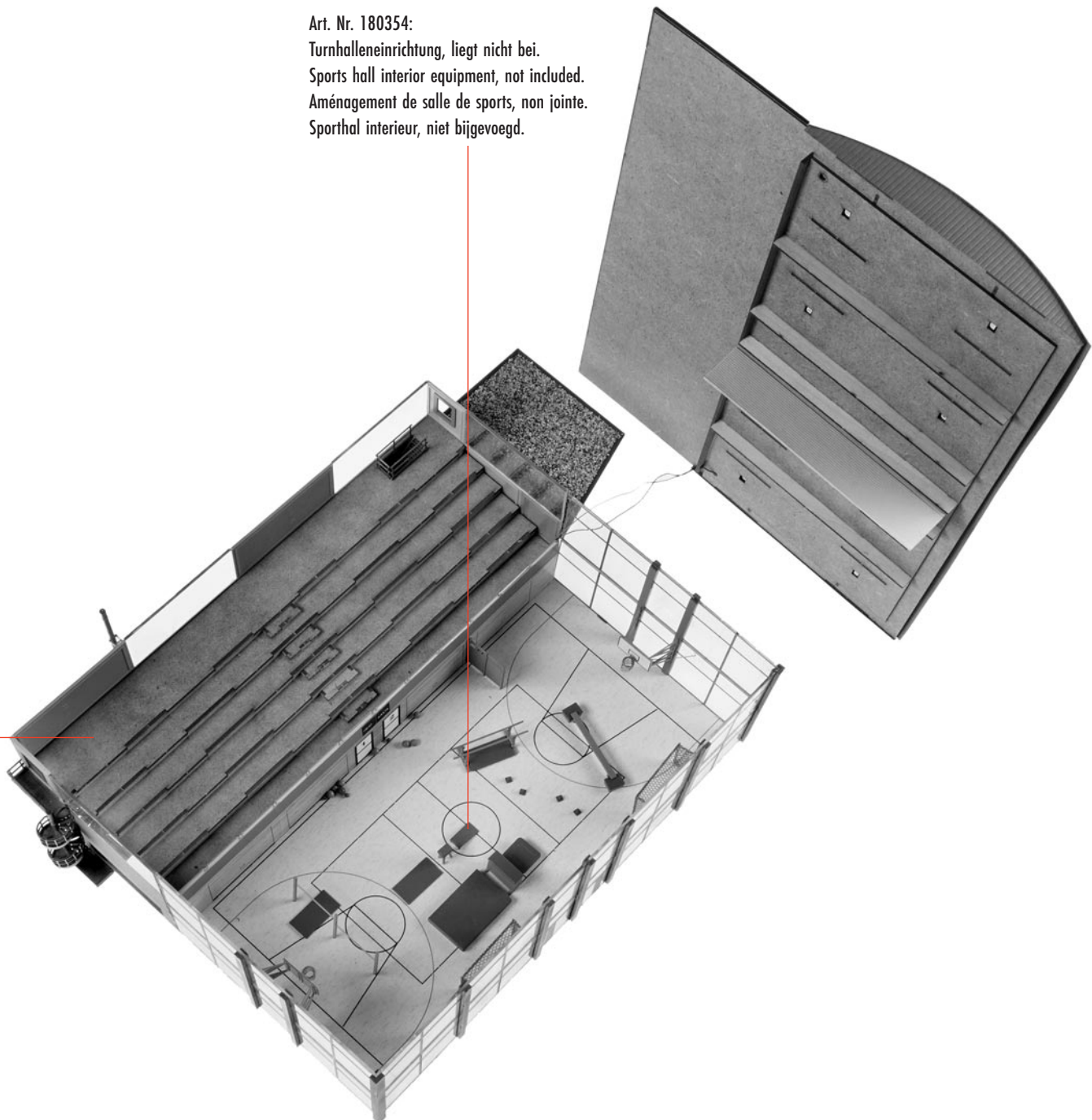

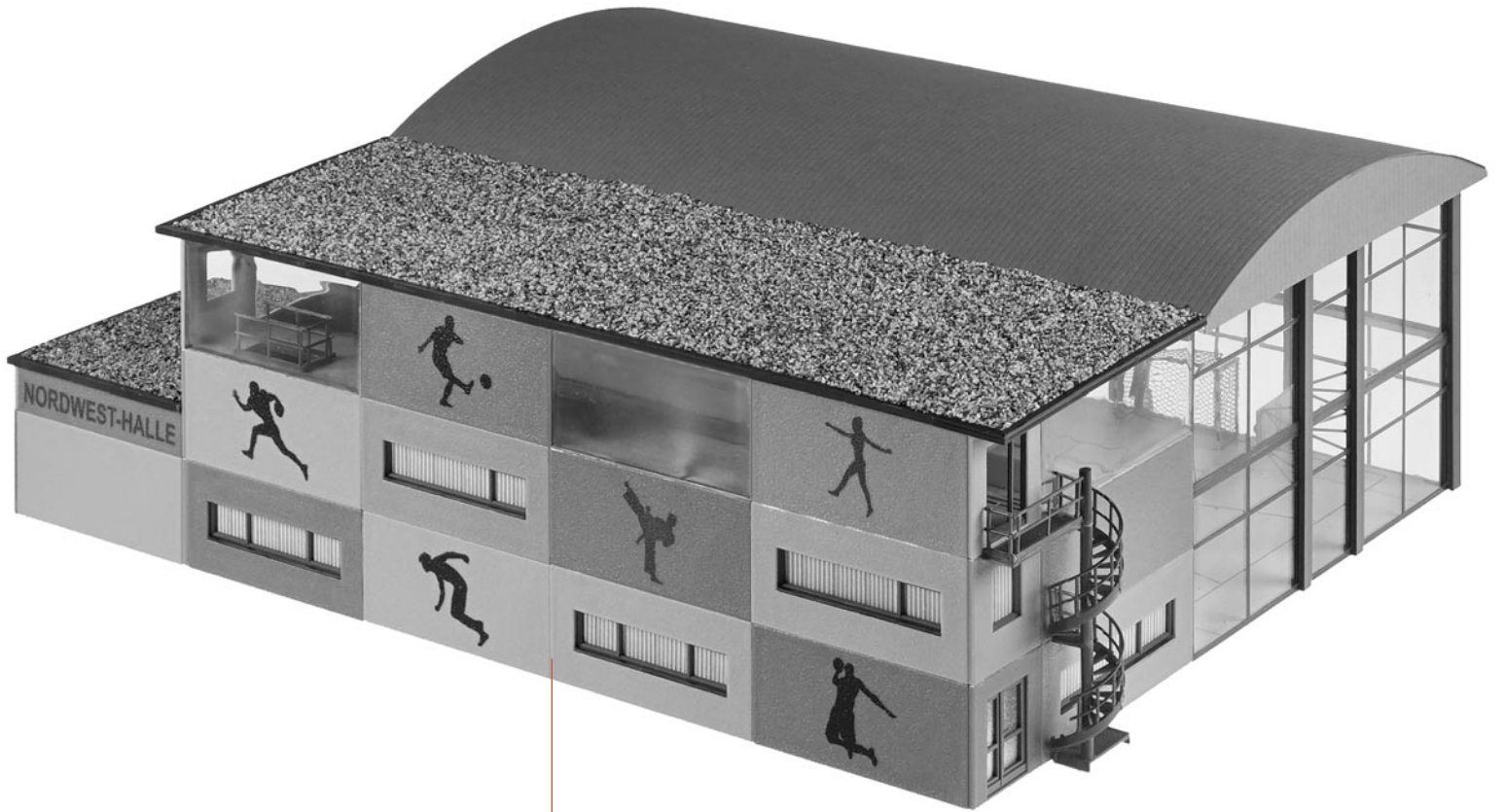

s

r

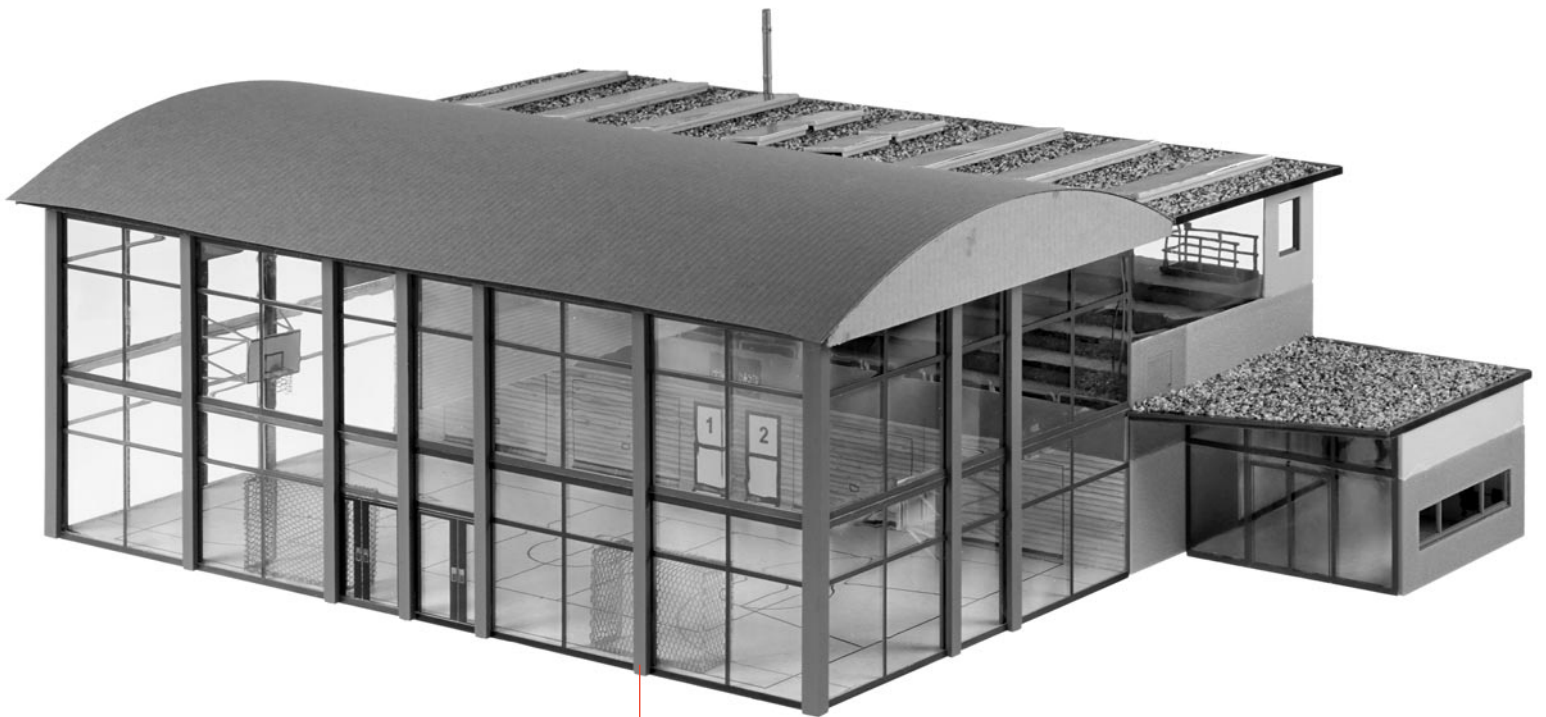

t

s