

TUNNELBOHRMASCHINE »GRIPPER-TBM«

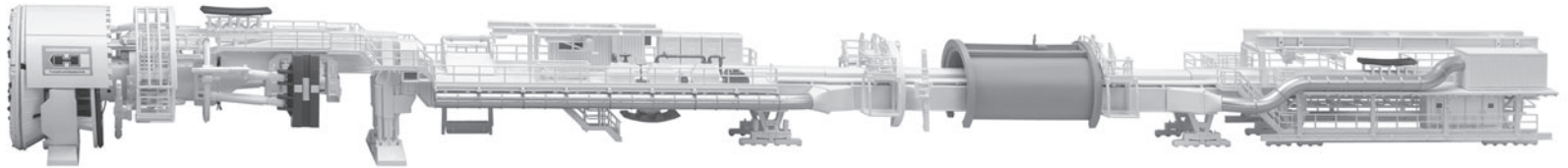

»GRIPPER TBM« TUNNEL BORING MACHINE
TUNNELIER »GRIPPER-TBM«
TUNNELBOORMACHINE »GRIPPER-TBM«

Art. Nr. 130900



Inhalt	Spritzlinge	1 AB 1 x	3 AB 1 x	7 BC 8 x	9 AB 3 x	11ABCD 1 x
Contents	Sprues	1 CD 1 x	4 A 1 x	7 C 4 x	10 A 2 x	12 AC 4 x
Contenu	Moulages	1 D 1 x	6 AB 6 x	7 D 7 x	11 A 2 x	12 C 7 x
Inhoud	Gietstukken	2 A 2 x	6 B 4 x	8 A 3 x	11 AB 1 x	13 ABC 4 x
		2 B 2 x	7 A 2 x	9 A 3 x	11ABD 3 x	50 C 1 x

Sa. Nr. 130 900 1

D Machen Sie sich bitte vor Beginn des Bastelns mit dem Bausatzinhalt und der Anleitung vertraut und prüfen Sie die Vollständigkeit. Im Reklamationsfall gilt die gesetzliche Gewährleistungspflicht. Sollte ein Teil fehlen, übersenden Sie bitte den Teilwunsch und den Kaufbeleg an: Gebr. FALLER GmbH, Kundendienst, Kreuzstraße 9, D-78148 Gütenbach, kundendienst@faller.de. Sollten Sie einmal weitere Ersatzteile benötigen, senden wir Ihnen den benötigten Spritzling, bei Verfügbarkeit, gerne kostenpflichtig zu. Bitte beachten Sie, dass produktionsbedingt Einzelteile übrig bleiben können.

GB Before building your model, please familiarize yourself with the contents of the kit and the instructions for use, also checking whether the set of parts is complete. In case of any complaint, the legal guarantee obligation shall apply. Should a part be missing, please send the designation of the part required and the receipt documenting your purchase to: Gebr. FALLER GmbH, Kundendienst, Kreuzstraße 9, D-78148 Gütenbach, kundendienst@faller.de. Should you require further spare parts one day, we shall be pleased to send you, with costs, the required sprue, if it is available. Please note that, on grounds of the production process, some single injection molded parts may be superfluous.

F Avant de commencer votre modèle, veuillez vous familiariser avec le contenu du kit et la notice d'emploi, et contrôlez que le lot de pièces est complet. En cas de réclamation, il s'appliquera l'obligation de garantie légale. Au cas où une pièce manquerait, veuillez envoyer la désignation de la pièce souhaitée et le bon d'achat à: Gebr. FALLER GmbH, Kundendienst, Kreuzstraße 9, D-78148 Gütenbach, kundendienst@faller.de. Au cas où vous auriez besoin un jour d'autres pièces détachées, nous vous enverrons volontiers la grappe requise, si elle est disponible, contre paiement. Veuillez noter que, pour des raisons de production, il se peut que des pièces détachées soient superflues.

NL Maak uzelf vóór het bouwen vertrouwd met de inhoud van het bouwpakket en met de handleiding en controleer de volledigheid. In geval van reclamatie geldt de wettelijke garantieverplichting. Mocht er een onderdeel ontbreken, stuurhet verzoek om het gewenste onderdeel en het aankoopbewijs dan naar: Gebr. FALLER GmbH, klantenservice, Kreuzstraße 9, D-78148 Gütenbach, kundendienst@faller.de. Als u ooit meer reserveonderdelen nodig hebt, sturen wij het benodigde gietstuk, indien beschikbaar, graag tegen betaling naar u op. Let op: om productieredenen kunnen losse onderdelen overblijven.

Für die Montage benötigen Sie Plastik-Klebstoff.

Wir empfehlen:

FALLER-Klebstoff EXPERT (Art. Nr. 170492)
Sekundenkleber
FALLER-Spezial-Seitenschneider (Art. Nr. 170688)
FALLER-Bastelmesser (Art. Nr. 170687)

For mounting you need plastic cement.

Our recommendation:

FALLER cement EXPERT (Art. No. 170492)
Instant modelling cement
FALLER special side cutter (Art. No. 170688)
FALLER modeller's knife (Art. No. 170687)

Pour le montage, utiliser de la colle plastique.

Nous vous recommandons les produits suivants:

Colle FALLER EXPERT (Art. Nr. 170492)
Colle rapide
Pince coupante diagonale spéciale FALLER (Art. Nr. 170688)
Couteau de bricolage FALLER (Art. Nr. 170687)

Voor de montage heeft u plasticlijm nodig.

Wij adviseren:
FALLER-plasticlijm EXPERT (Art. Nr. 170492)
Secondenlijm
FALLER-speciaal zijknijptang (Art. Nr. 170688)
FALLER-knutselmes (Art. Nr. 170687)

Art. Nr. 170490 | 170492 | 170494
FALLER SUPER-EXPERT | EXPERT | LASERCUT



Art. Nr. 170688
SPEZIAL-SEITENSCHNEIDER



Art. Nr. 170687
FALLER-BASTELMESSER



2 Alle angefangenen Spritzlinge nach Gebrauch unbedingt wieder zurück in die dazugehörige Tüte legen, um die nötige Übersicht beizubehalten.

Every moulded part you have started to use should imperatively be put back in the corresponding bag, after use, to maintain the general view that is needed.

Il faut absolument remettre dans la sachet correspondante, après utilisation, toutes les grappes entamées afin de conserver la vue d'ensemble nécessaire.

Elk deels bewerkt spuitgietstuk na gebruik absoluut weer terug doen in de bijbehorende zakje om het noodzakelijke overzicht te kunnen behouden.

Inhalt	Spritzlinge Tüte 1	T 1	Inhalt	Spritzlinge Tüte 2	T 2	Inhalt	Spritzlinge Tüte 3	T 3	Inhalt	Karton	
Contents	Moulded parts bag 1	T 1	Contents	Moulded parts bag 2	T 2	Contents	Moulded parts bag 3	T 3	Contents	Carton	
Contenu	Grappes sachet 1	T 1	Contenu	Grappes sachet 2	T 2	Contenu	Grappes sachet 3	T 3	Contenu	Carton	
Inhoud	Spuitgietstuk zakje 1	T 1	Inhoud	Spuitgietstuk zakje 2	T 2	Inhoud	Spuitgietstuk zakje 3	T 3	Inhoud	Karton	
	6 AB	6 x		2 B	2 x		12 AC	4 x		1 AB	1 x
	6 B	4 x		11 A	2 x		12 C	7 x		2 A	2 x
				11 AB	1 x					4 A	1 x
				11 ABD	3 x					7 A	2 x
				11 ABCD	1 x					7 BC	8 x
				13 ABC	4 x					7 C	4 x
										10 A	2 x
Inhalt	Spritzlinge Tüte 4	T 4	Inhalt	Spritzlinge Tüte 5	T 5	Inhalt	Spritzlinge Tüte 6	T 6			
Contents	Moulded parts bag 4	T 4	Contents	Moulded parts bag 5	T 5	Contents	Moulded parts bag 6	T 6			
Contenu	Grappes sachet 4	T 4	Contenu	Grappes sachet 5	T 5	Contenu	Grappes sachet 6	T 6			
Inhoud	Spuitgietstuk zakje 4	T 4	Inhoud	Spuitgietstuk zakje 5	T 5	Inhoud	Spuitgietstuk zakje 6	T 6			
	3 AB	1 x		1 CD	1 x		Motor				
	8 A	3 x		1 D	1 x		Kabel				
	9 A	3 x		7 D	7 x		Schrauben				
	9 AB	3 x									
	50 C	1 x									



(A) 13 x

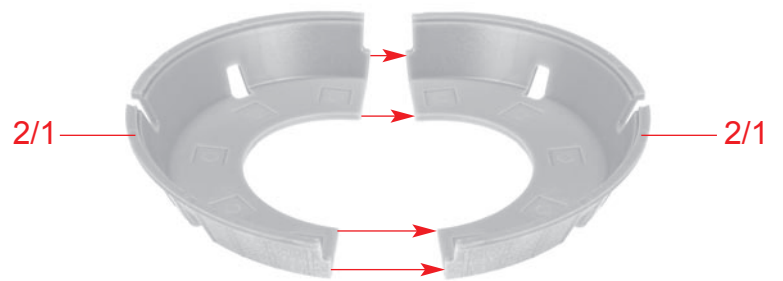

(B) Klebestellen gut abtrocknen lassen!
Laisser bien sécher les points de collage!
Allow glue joints to dry well!
Alle gelijmde punten goed laten drogen!

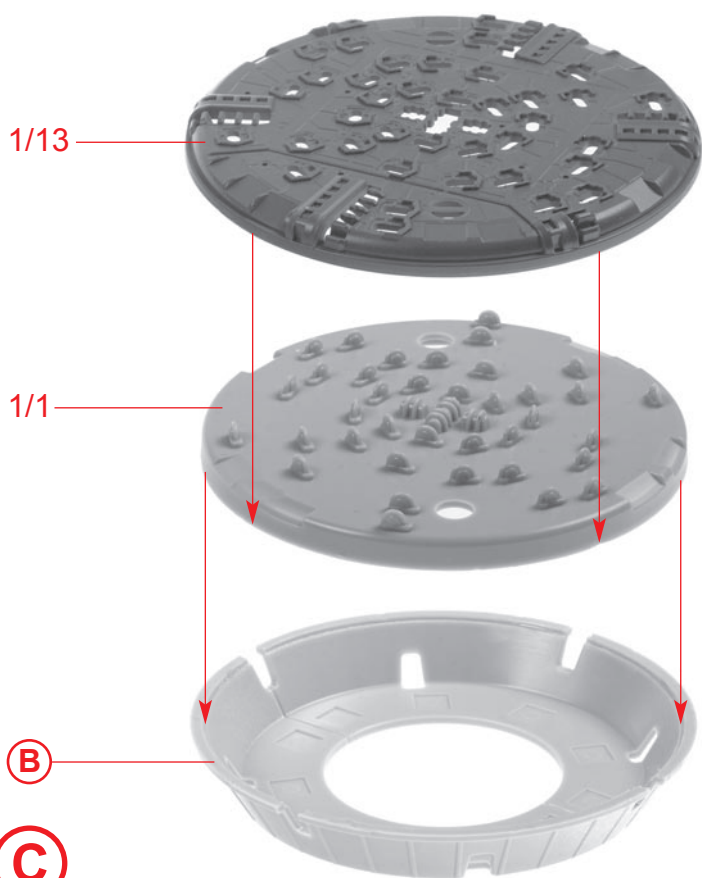

(B)

(C)



(D)

(C)

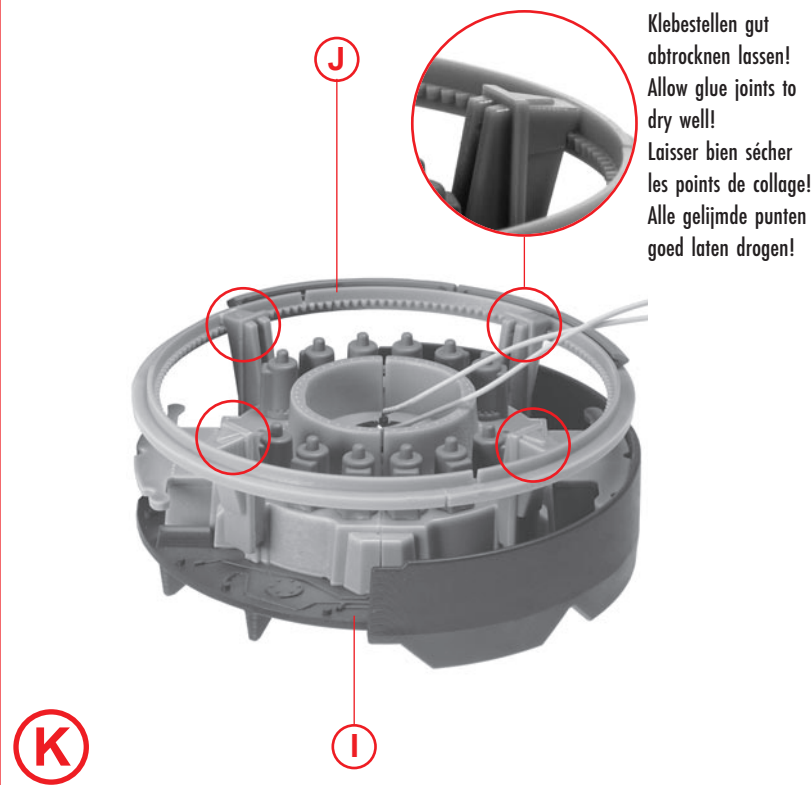
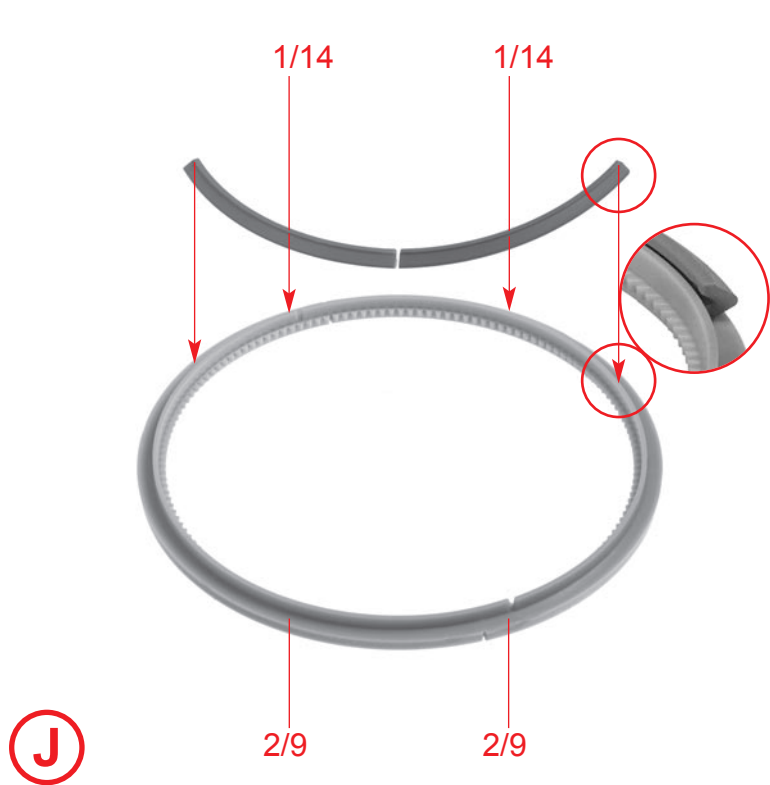
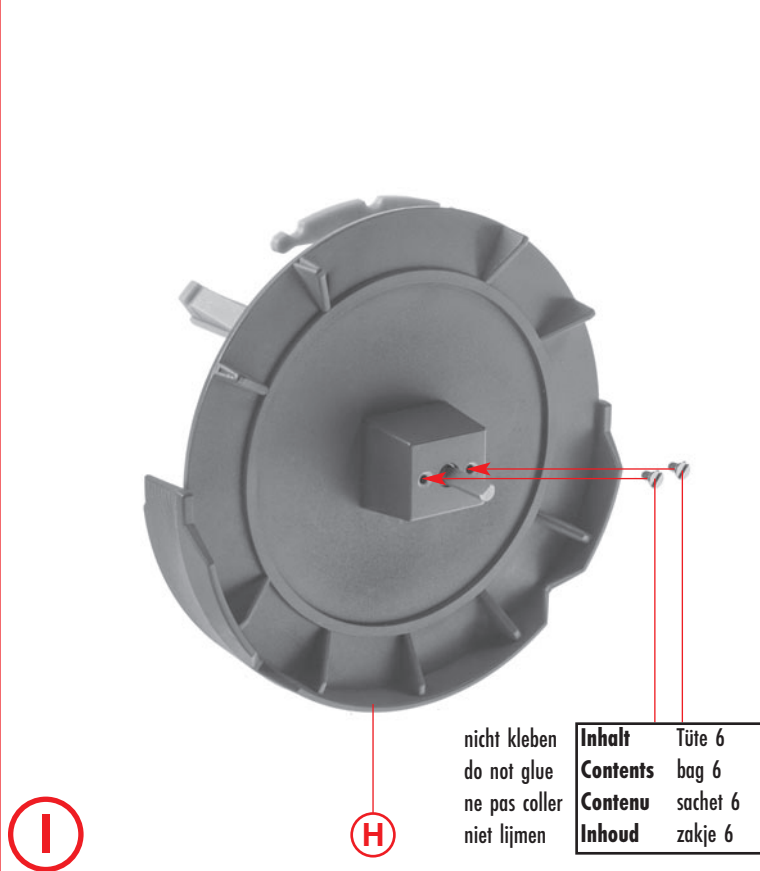
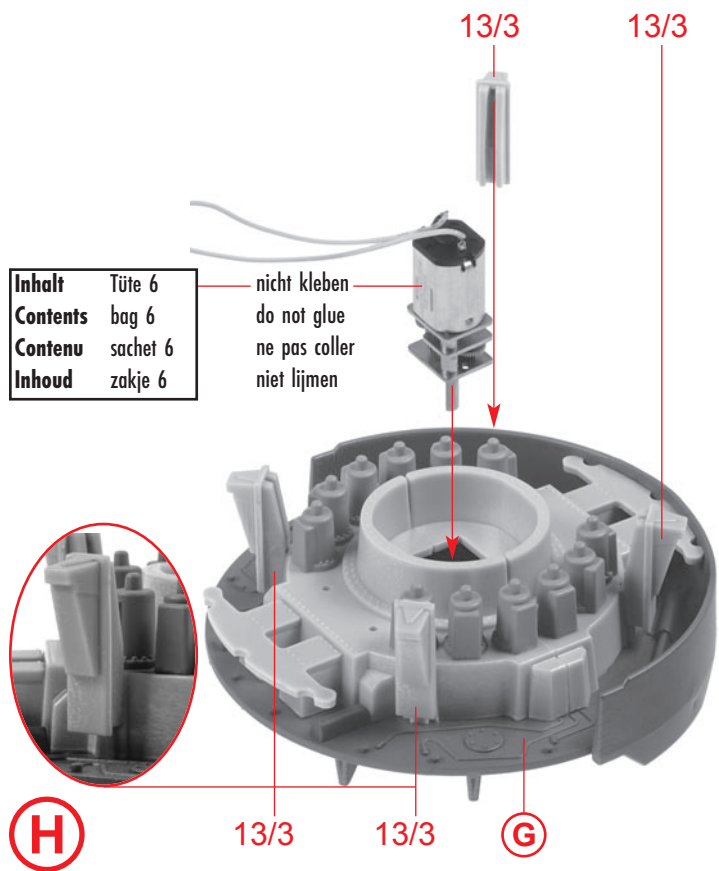
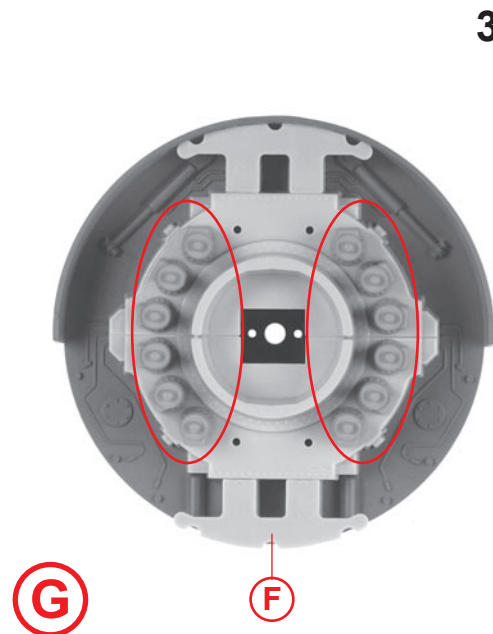
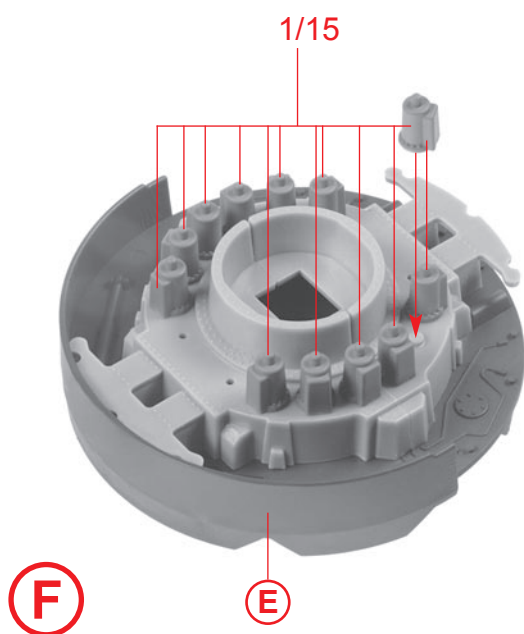
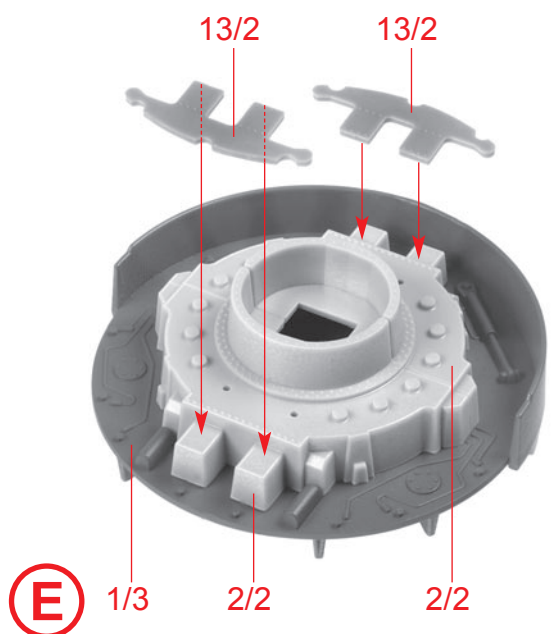

4

13/1 13/1 13/1 13/1

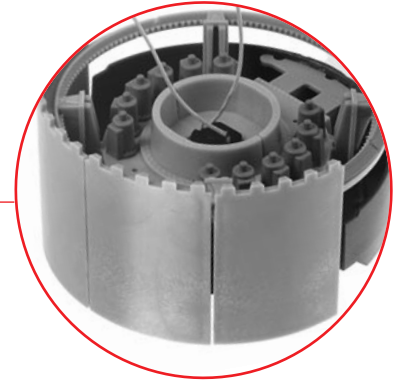
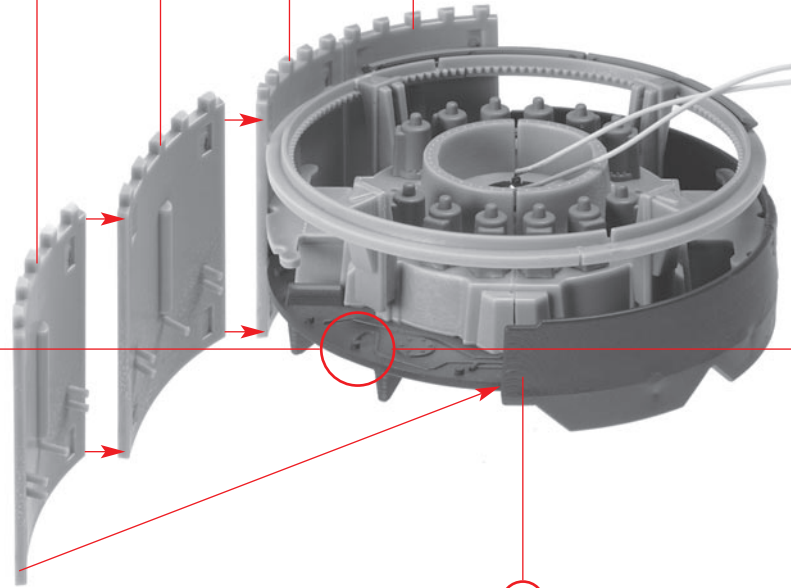

L

K

1/4

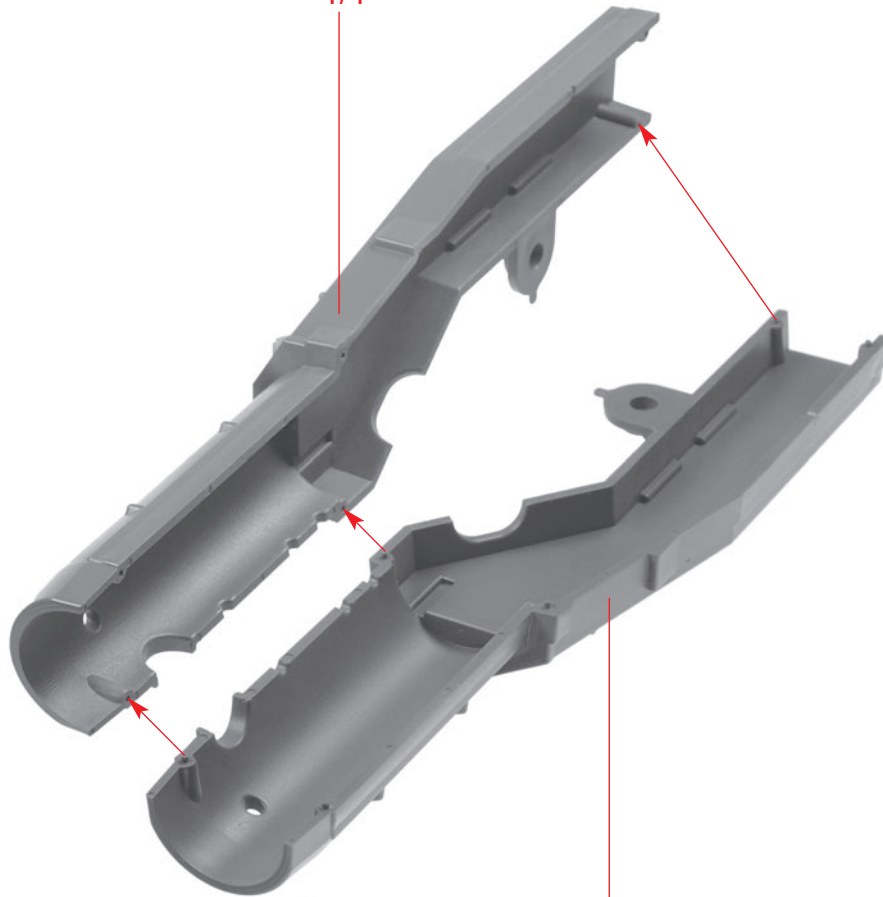

1/5

M

13/30

Nur an dieser Stelle kleben.
Only apply glue to this point.
Coller exclusivement cet emplacement.
Alleen op deze plaats lijmen.

13/28



13/29

N 4 x

N

N

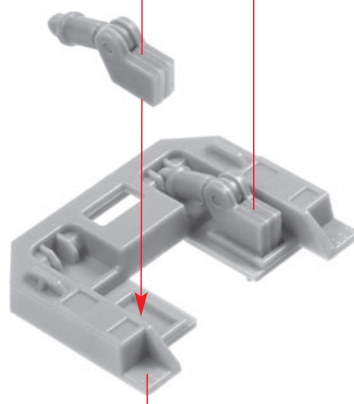

2/5

O 2 x

O

2/7

O

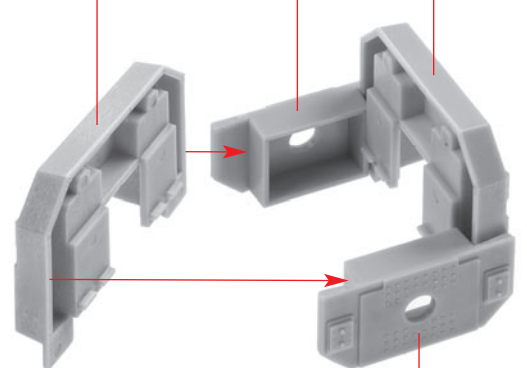

2/7

P

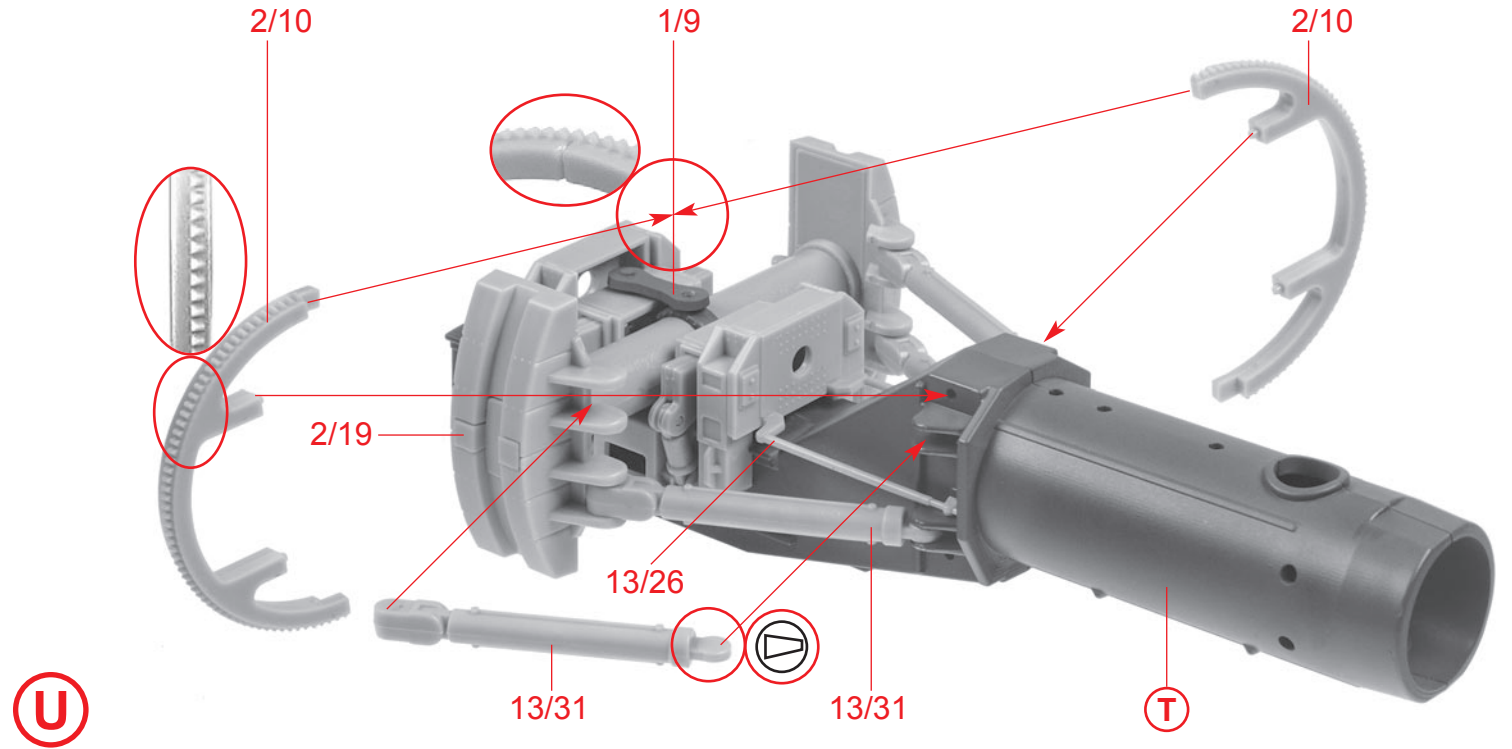
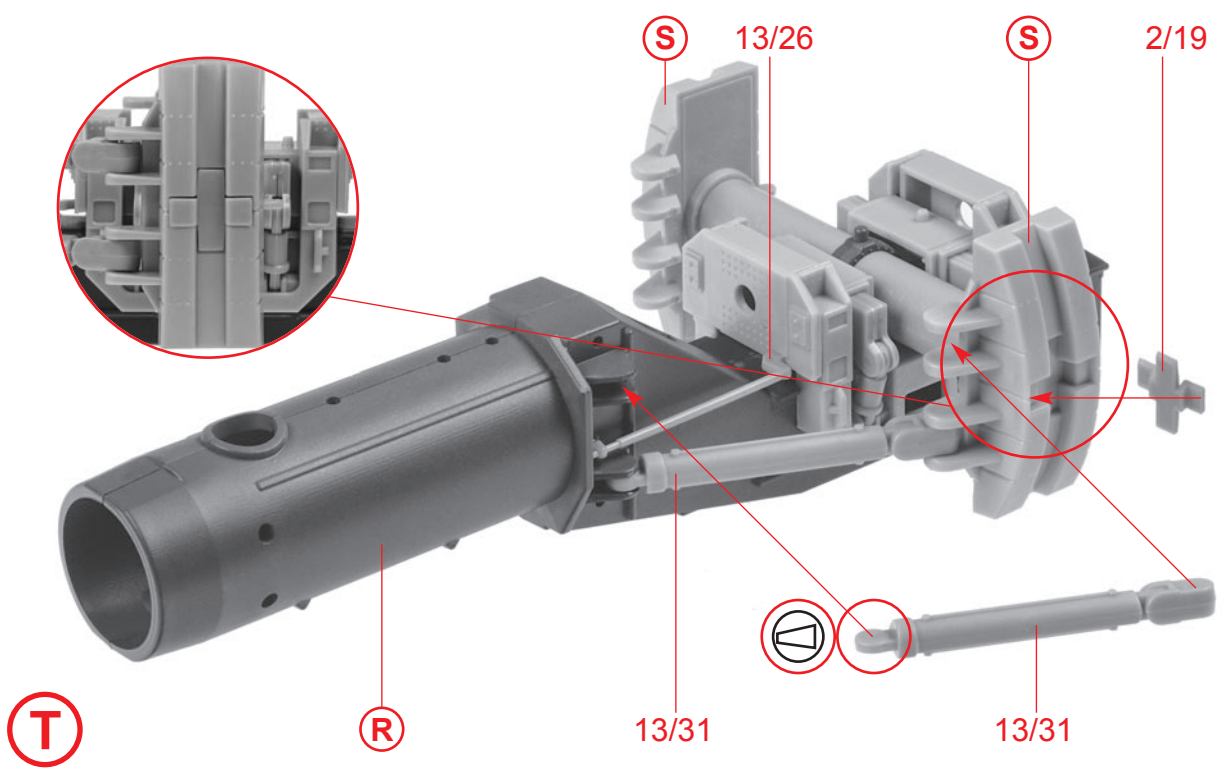
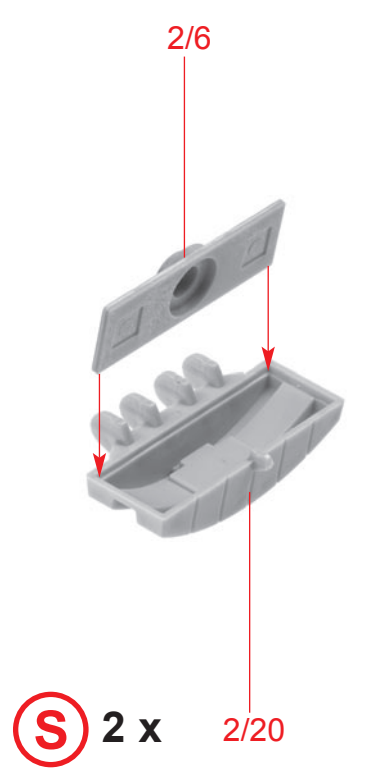
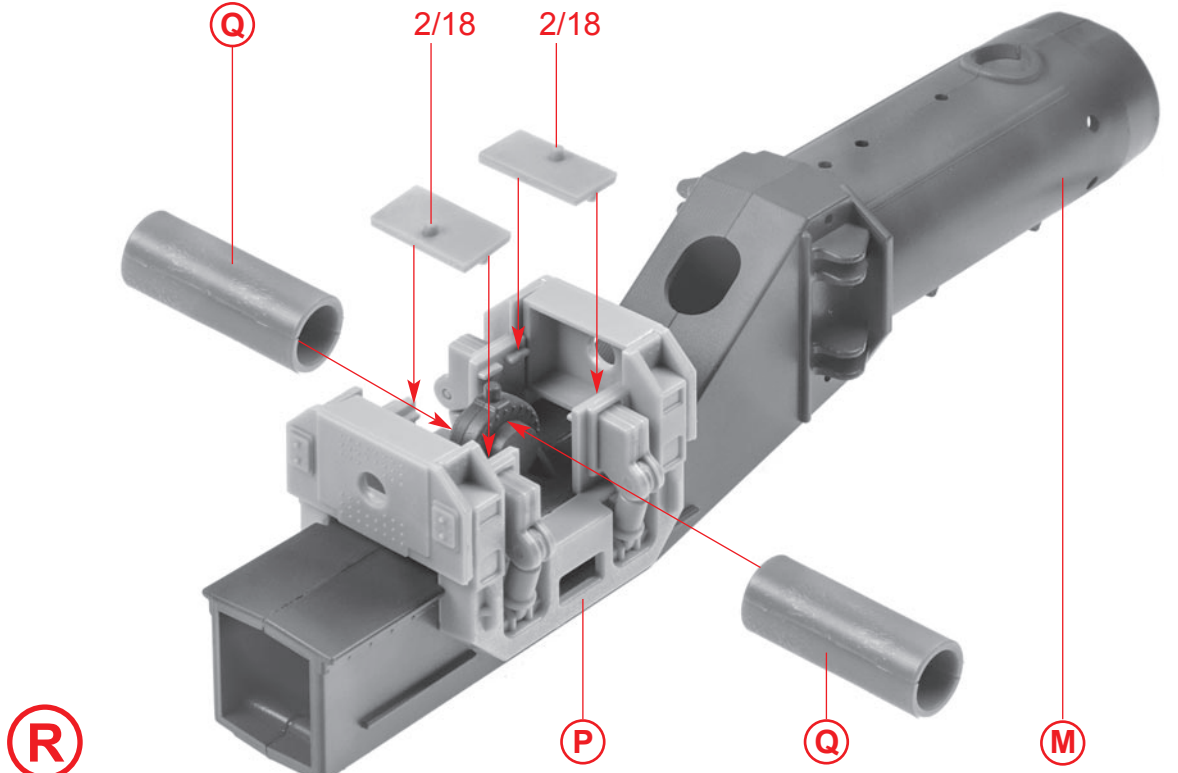
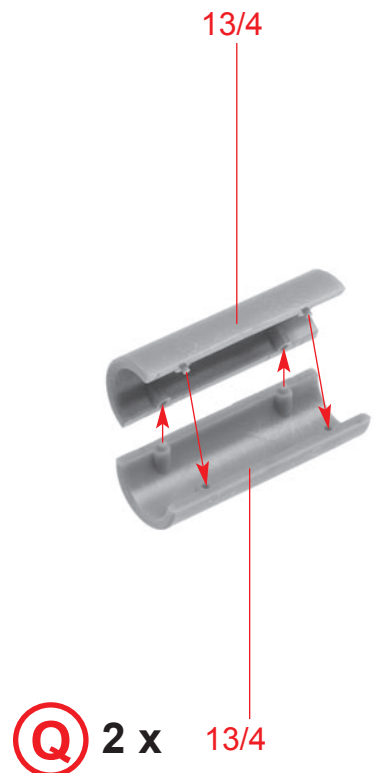

6

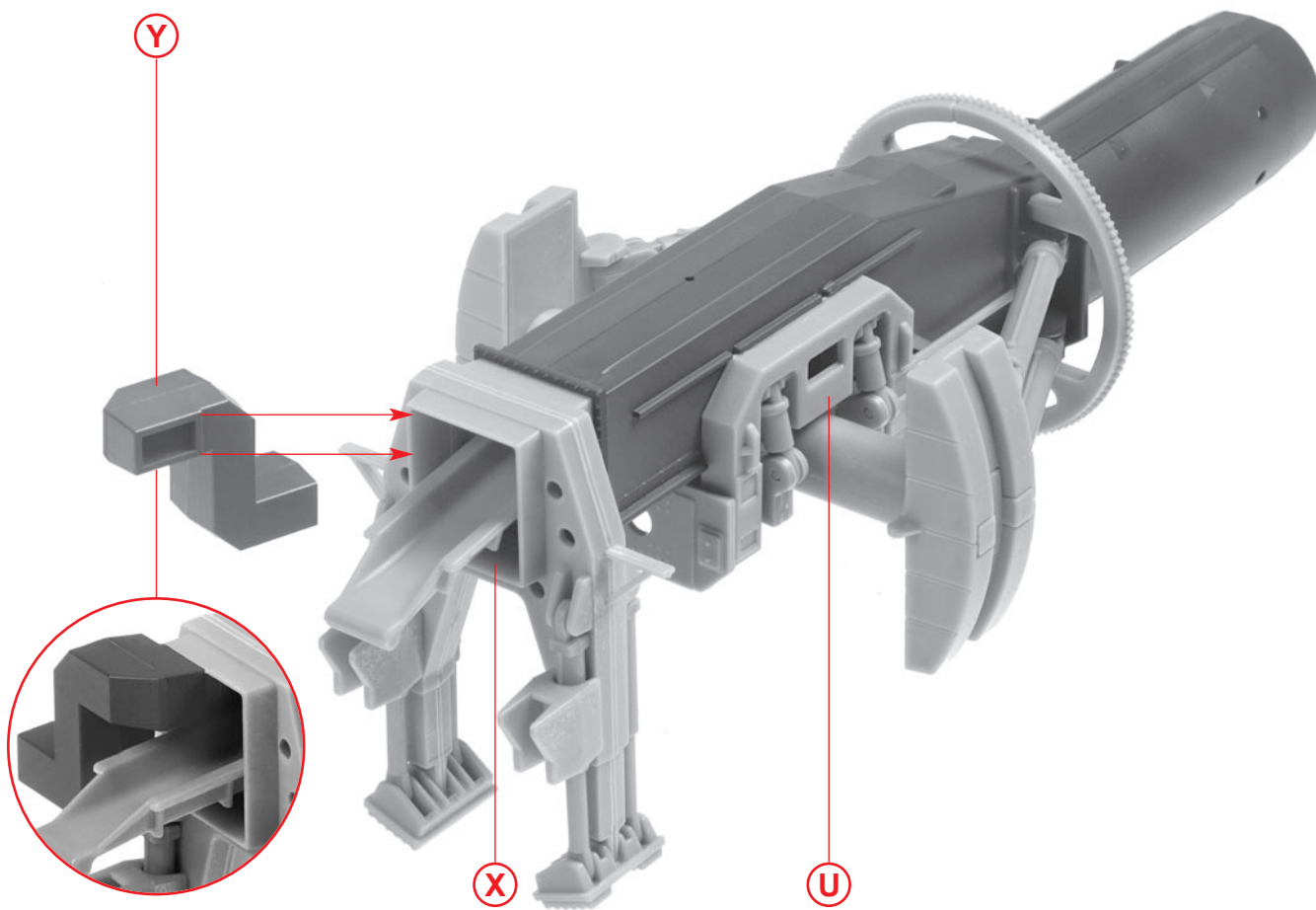
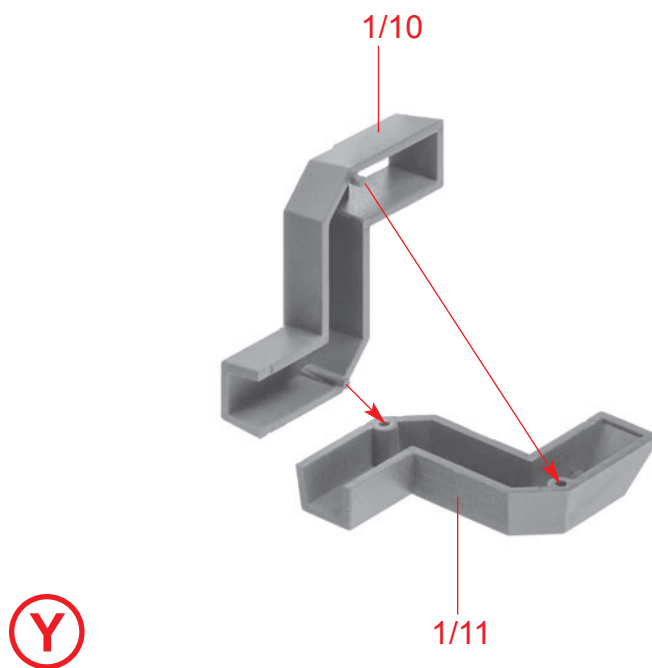
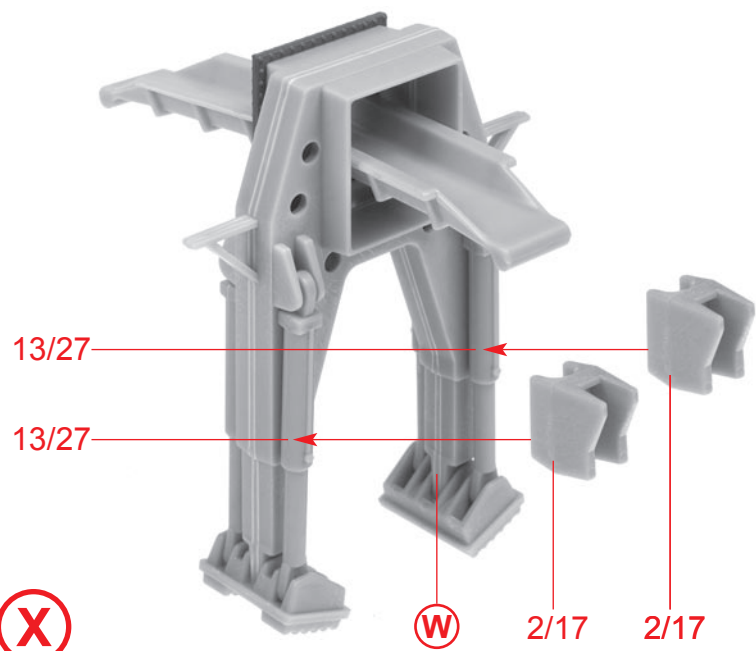
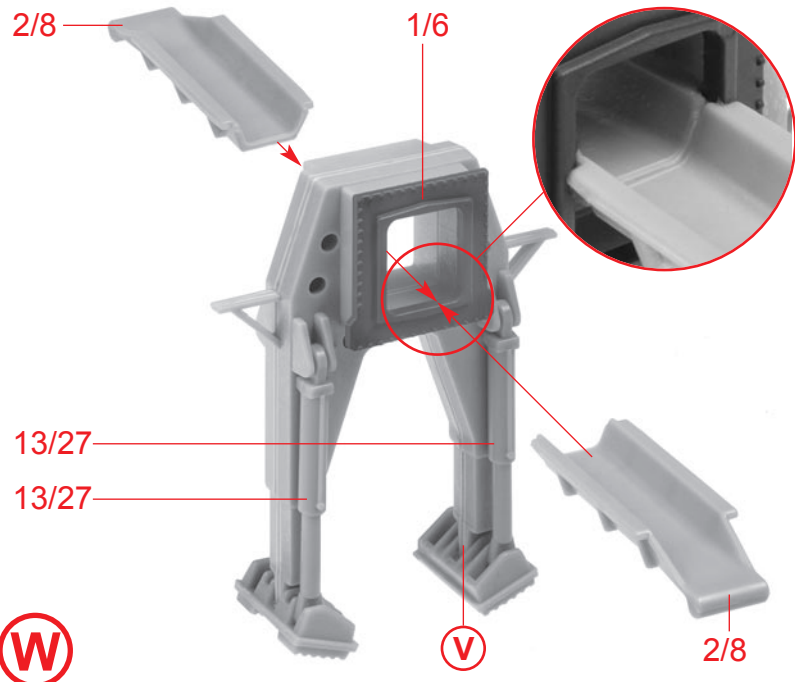
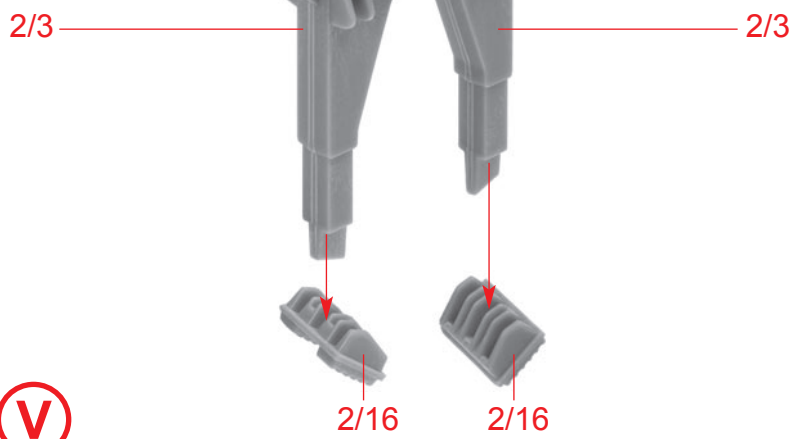

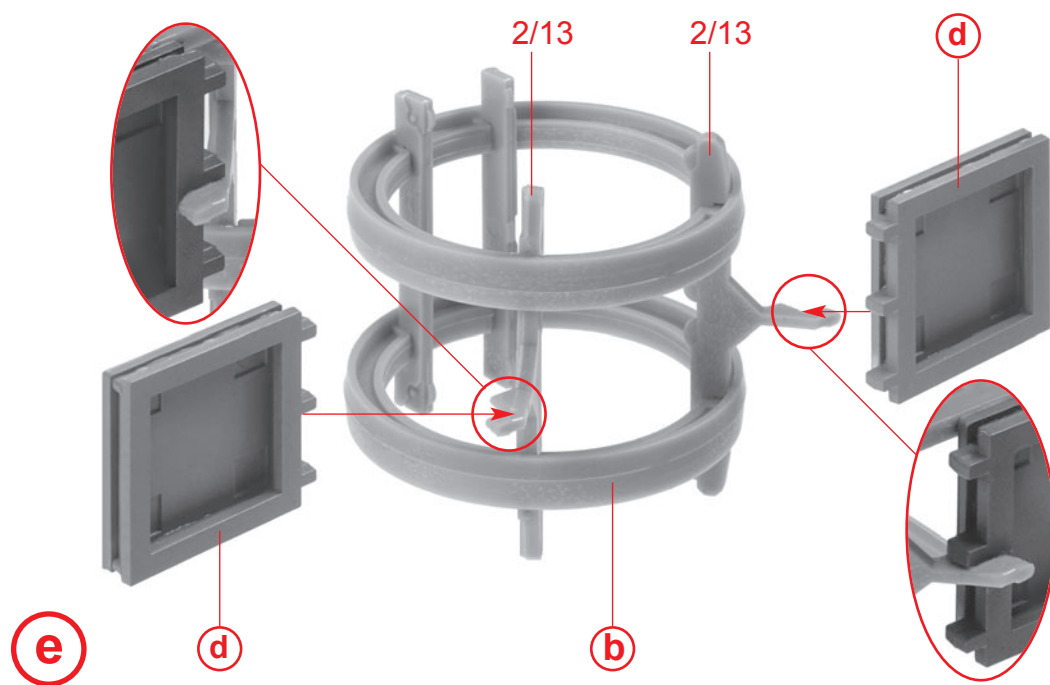
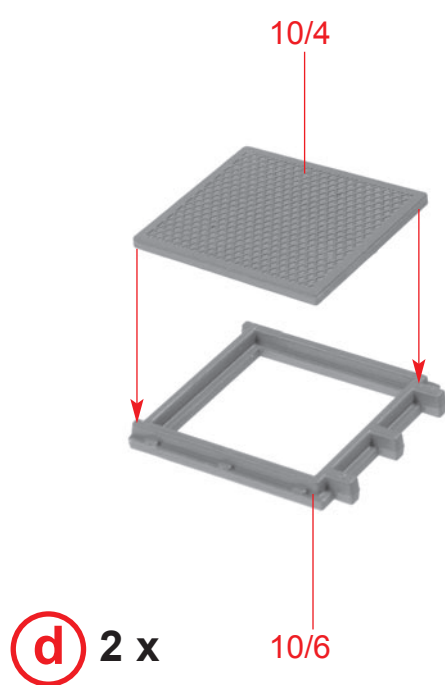
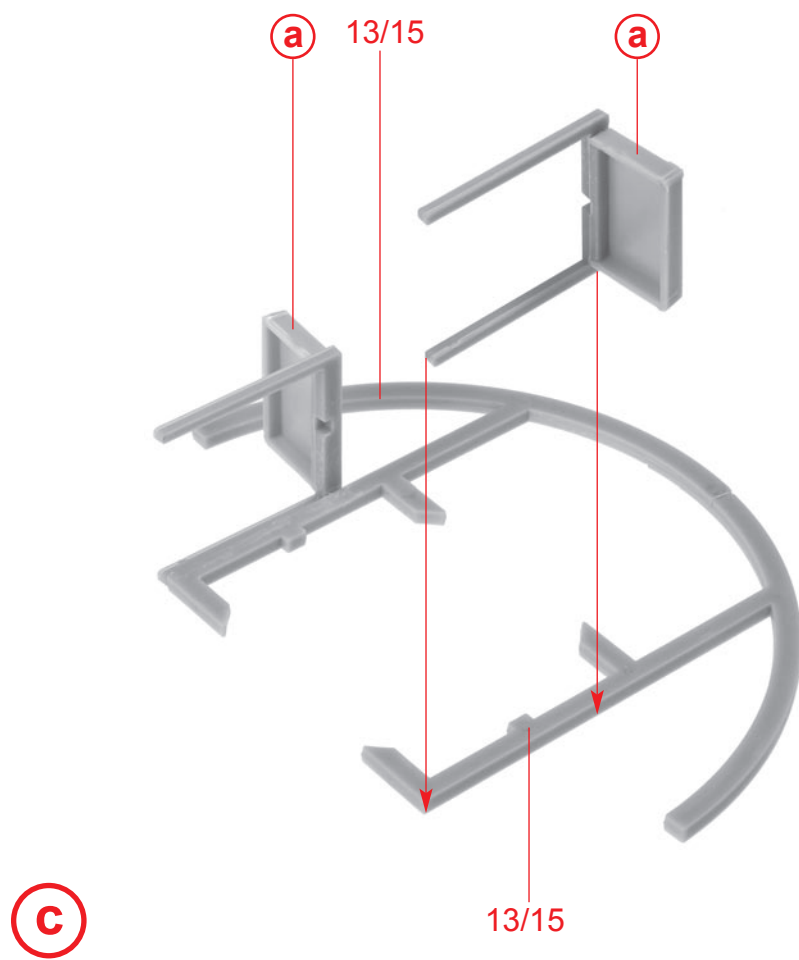
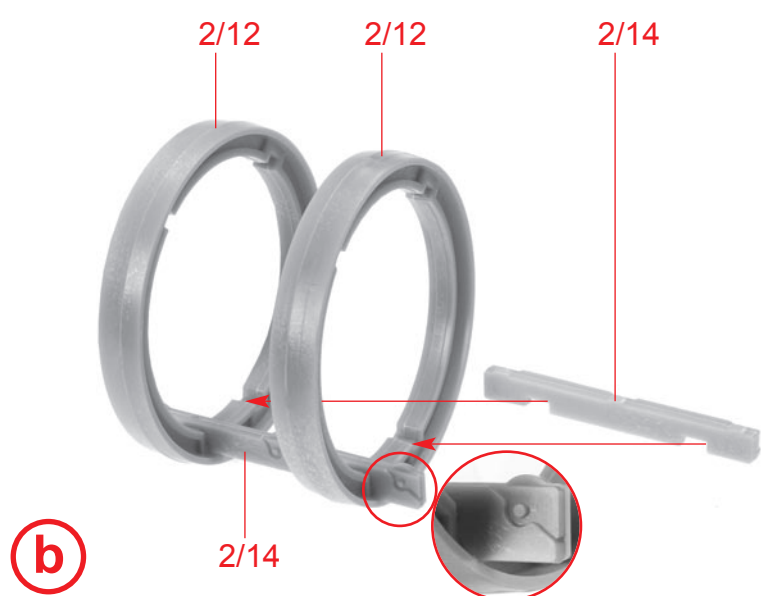
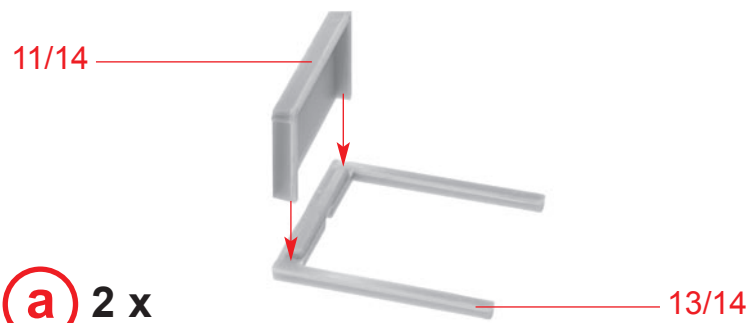

Klebestellen gut abtrocknen lassen!
 Allow glue joints to dry well!
 Laisser bien sécher les points de collage!
 Alle gelijmde punten goed laten drogen!

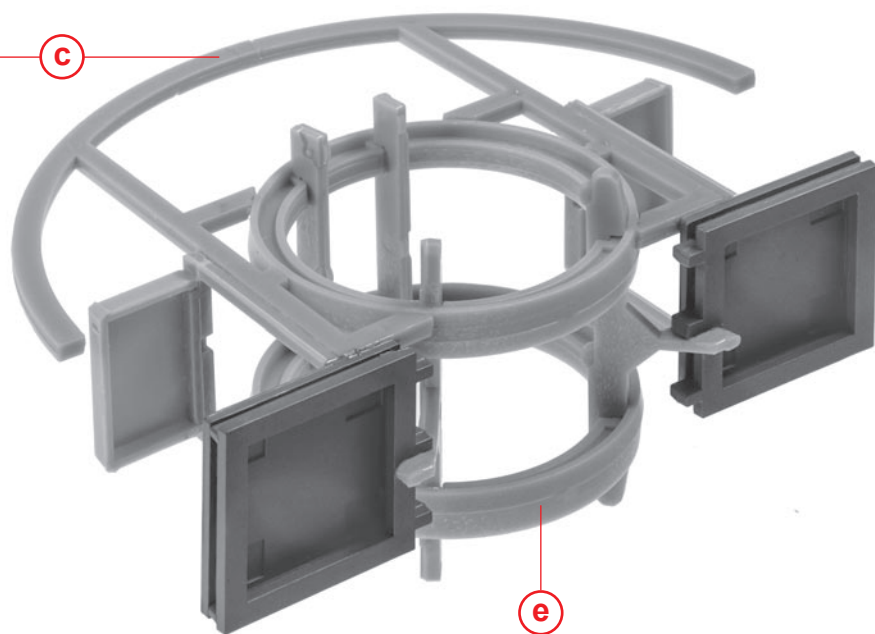

8

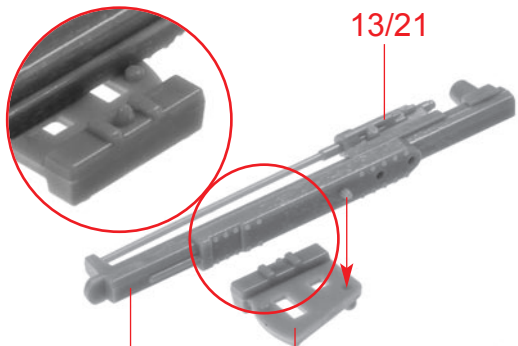

g

13/20 13/18

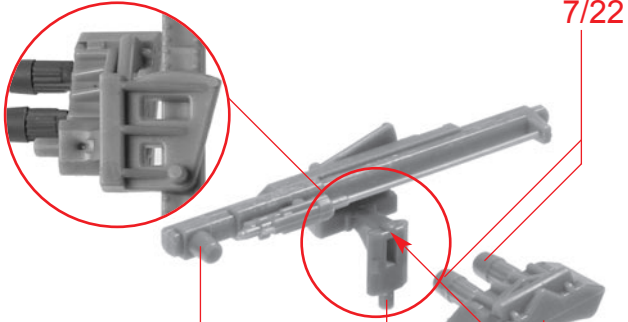

h

g 13/17 13/16

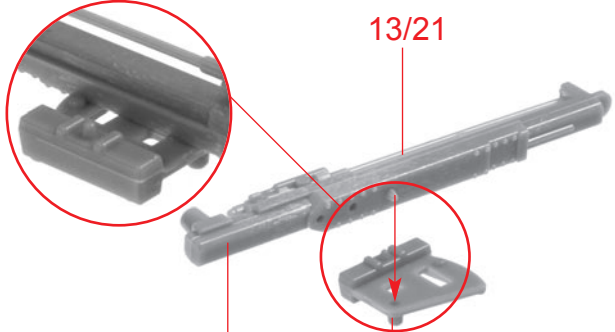

i

13/20 13/19

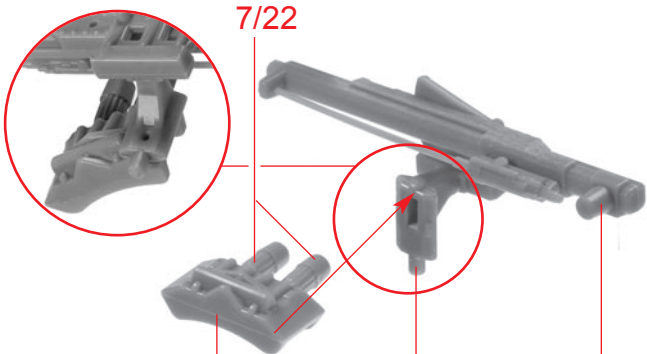

j

13/16 13/17 i

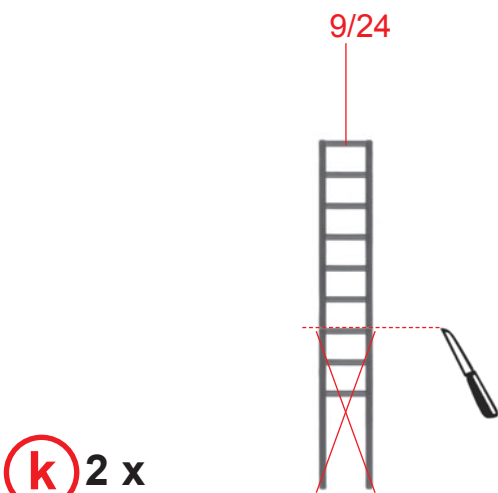

k 2 x

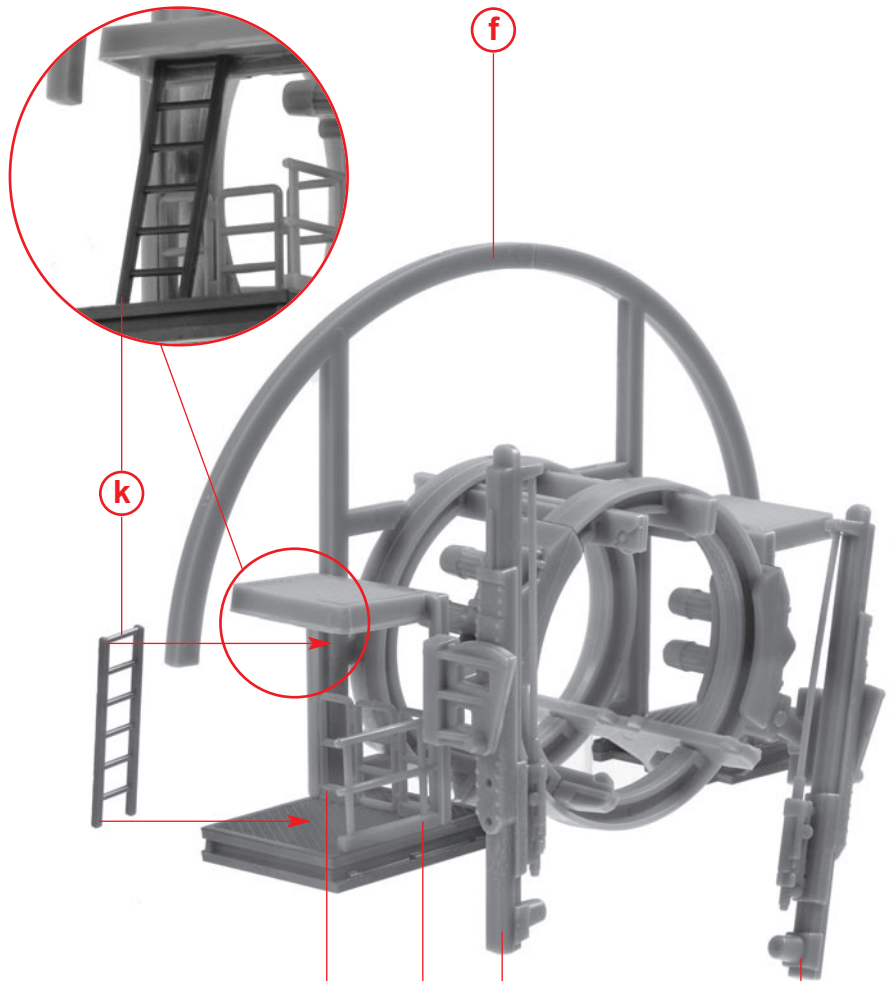

l

9/10 9/2 h j

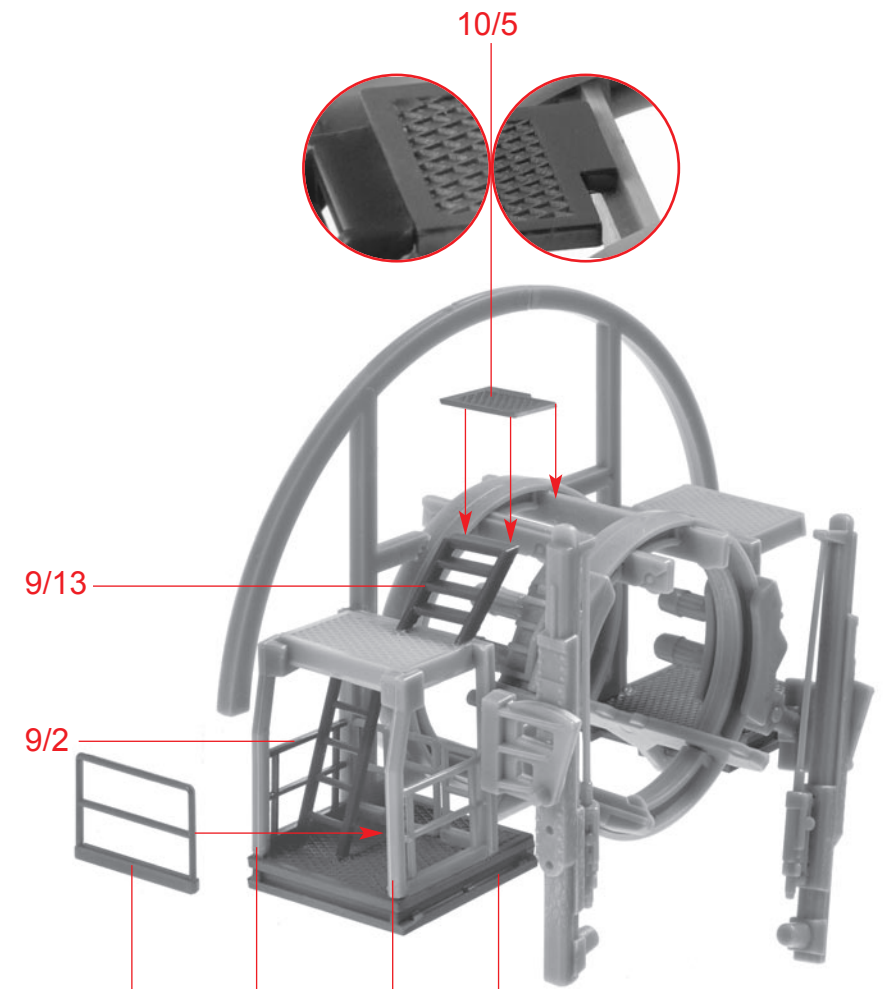

m

9/8 13/25 13/24 l

n 2 x 8/8

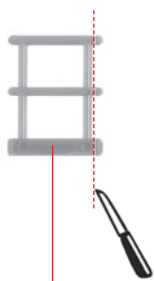

o 8/10

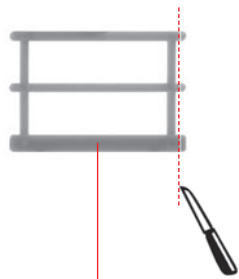

p

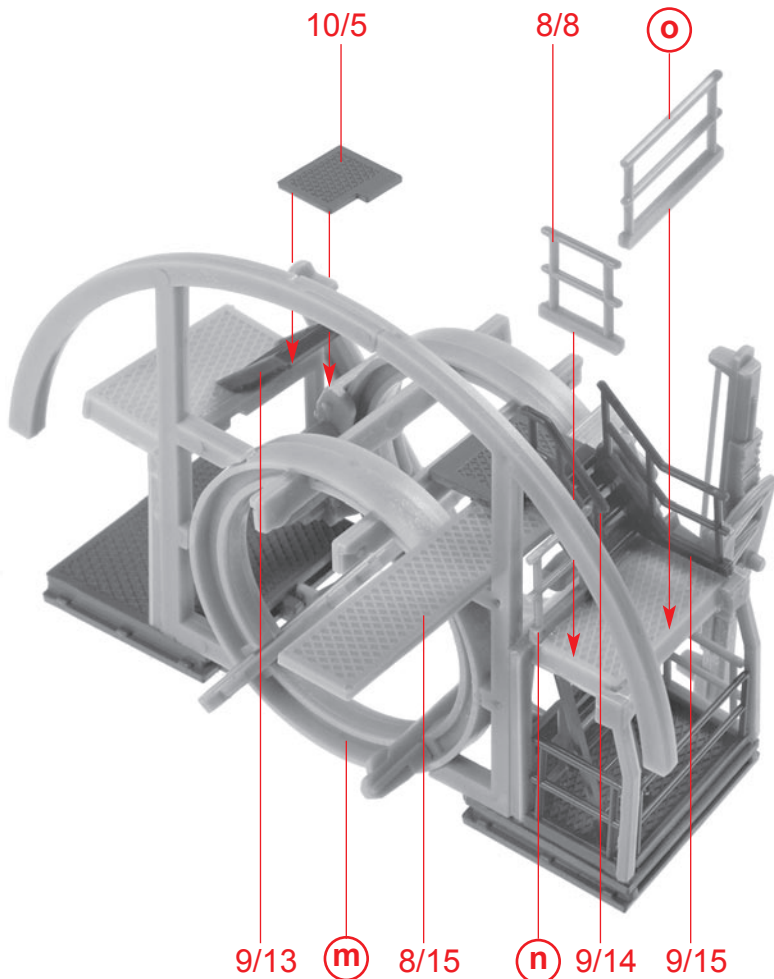

9/13 **m** 8/15 **n** 9/14 9/15

9/11

8/9

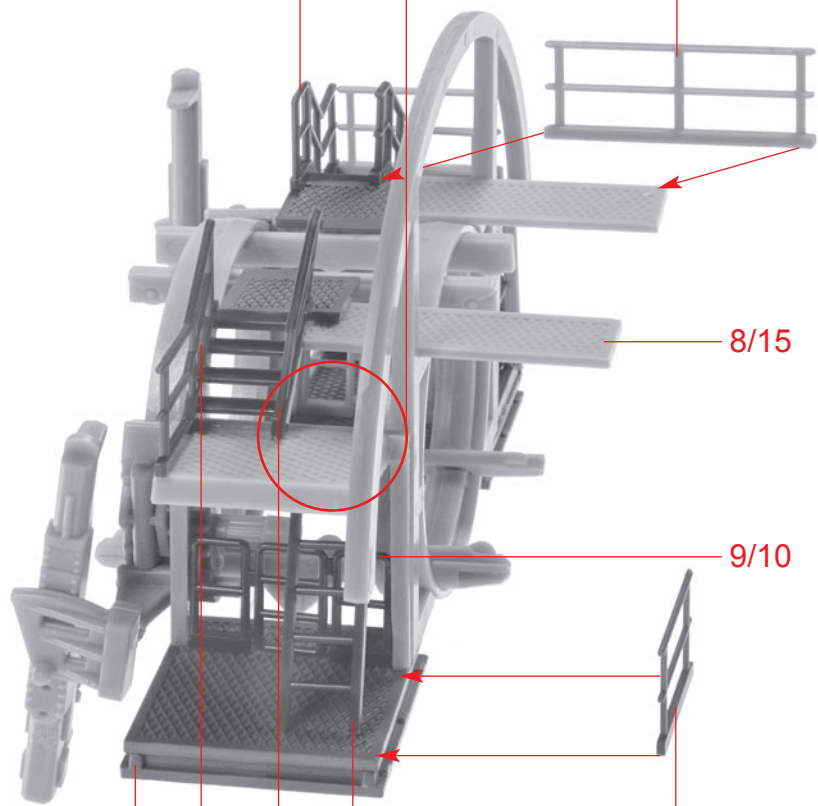
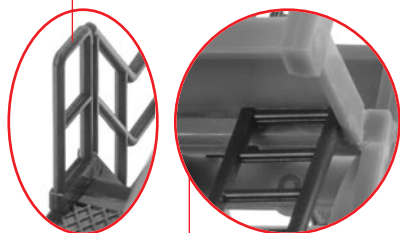

8/15

9/10

9/2

q **p** 9/15 9/14 **k**

8/10

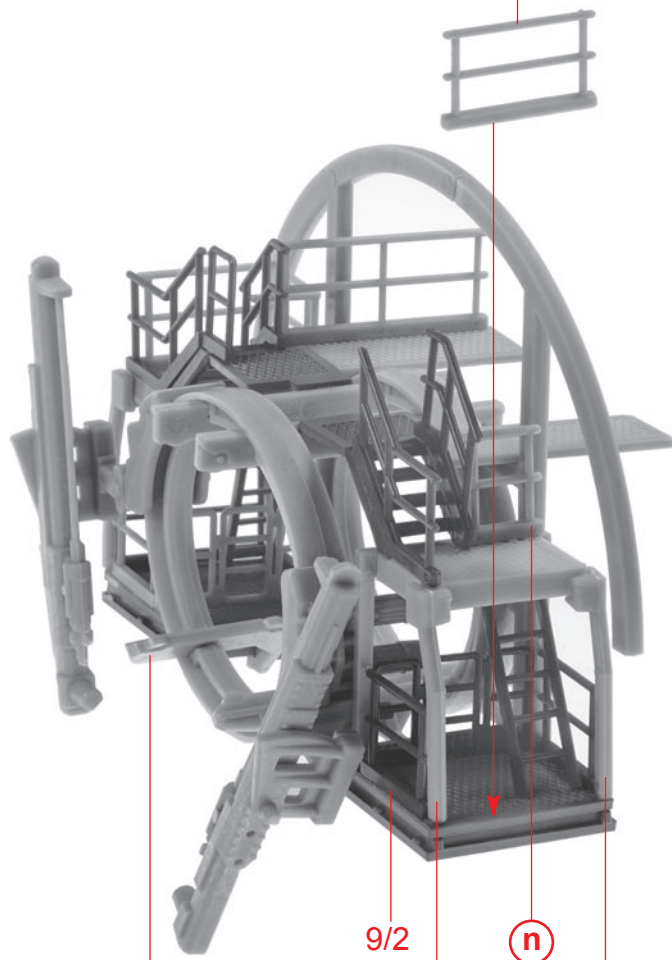

9/2

n

13/25

13/24

r **q**

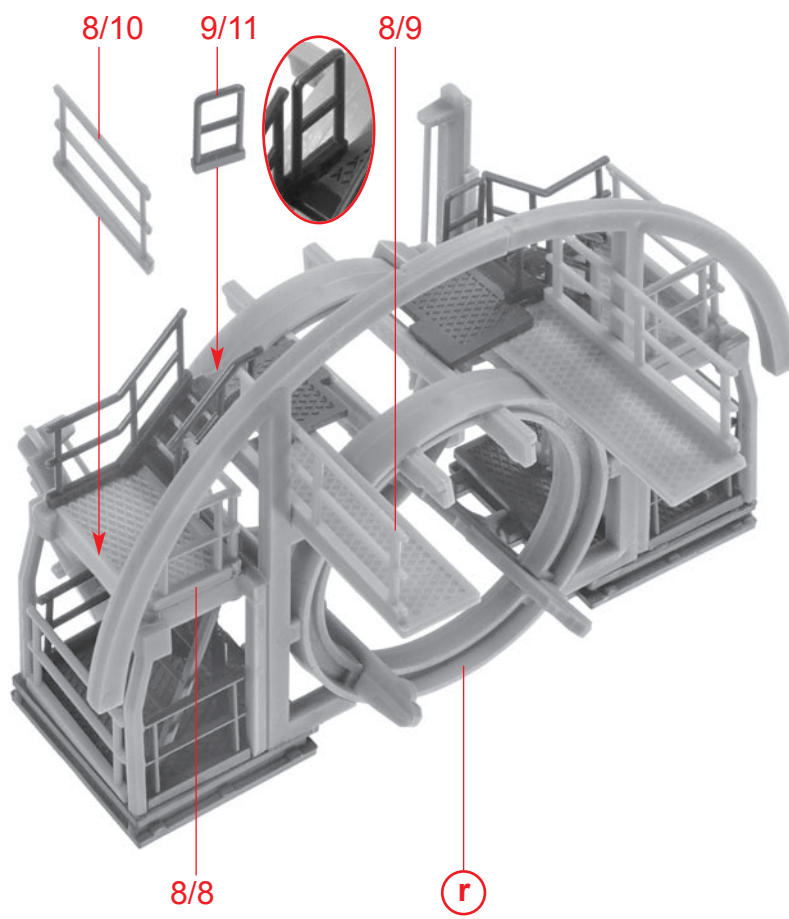

s

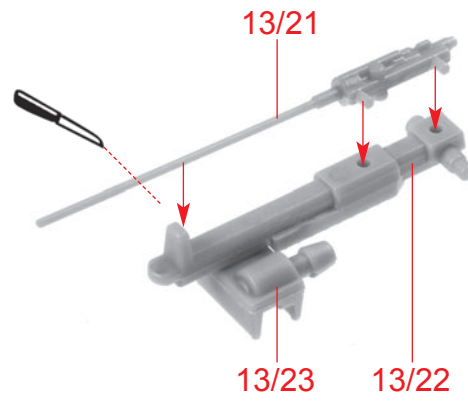

t

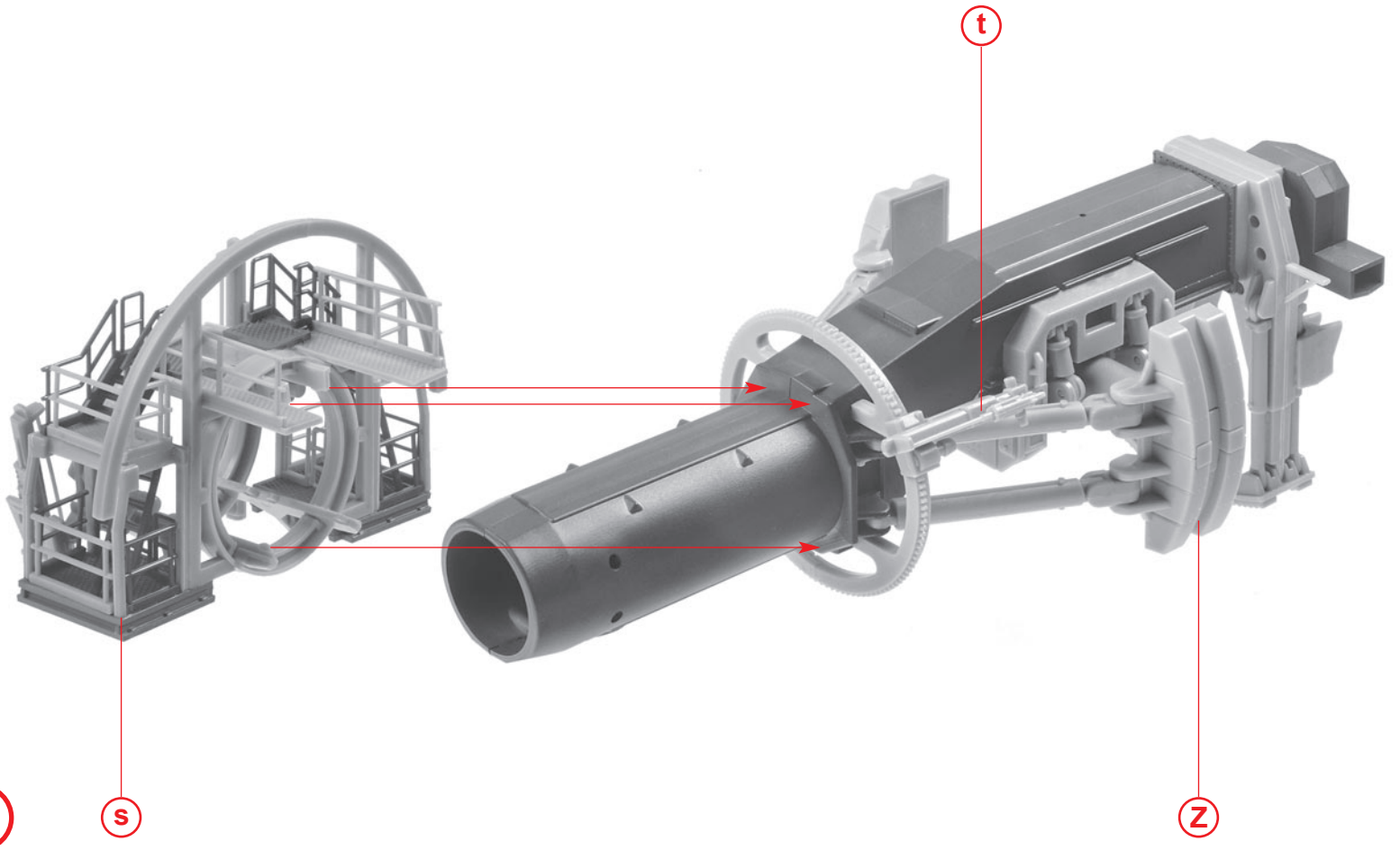

u

s

z

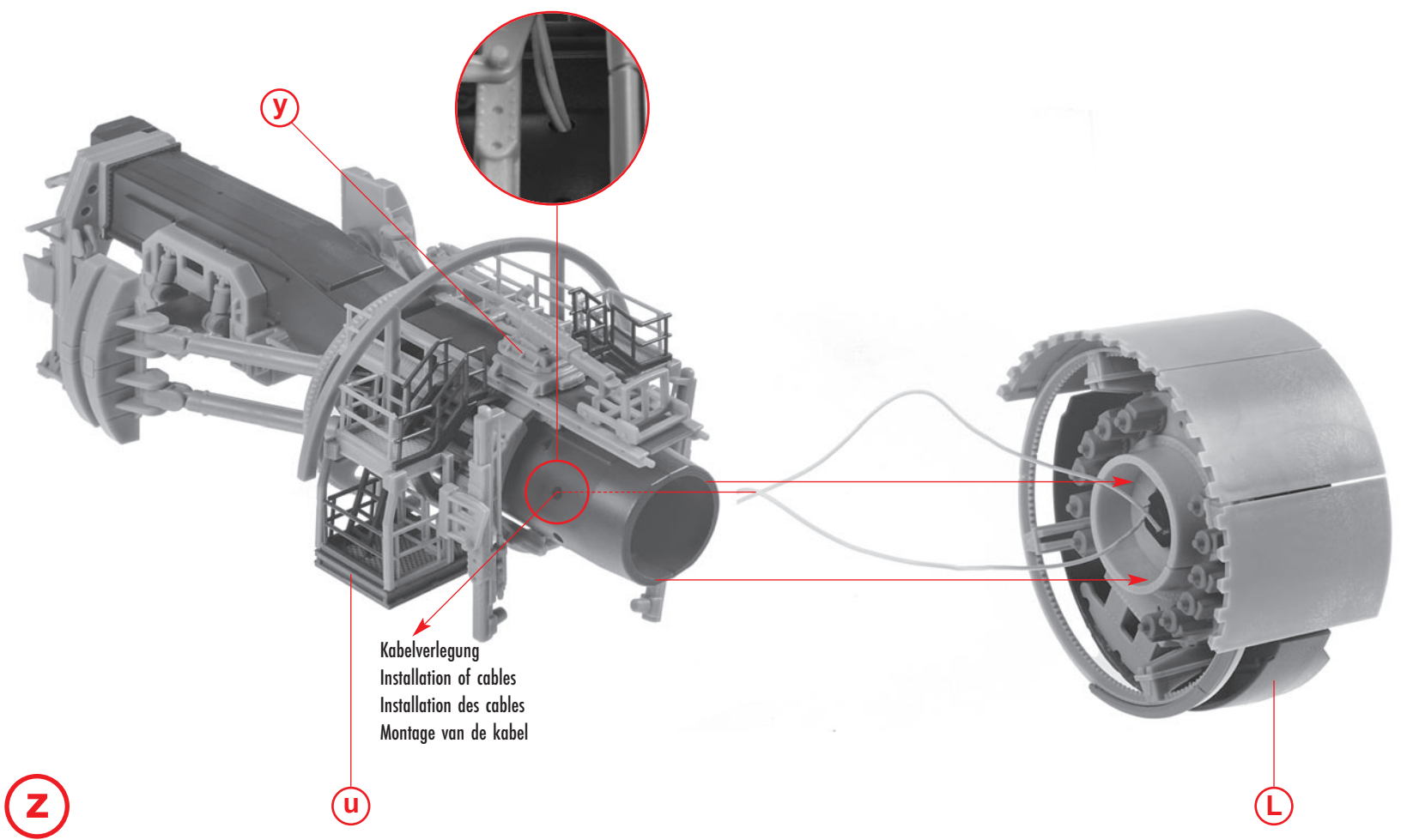
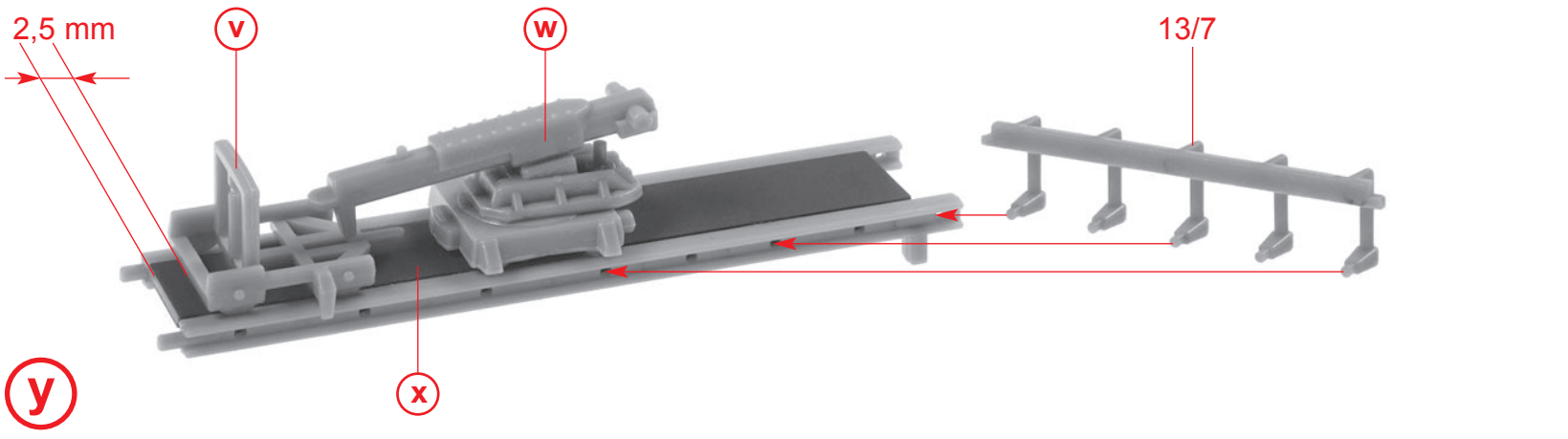
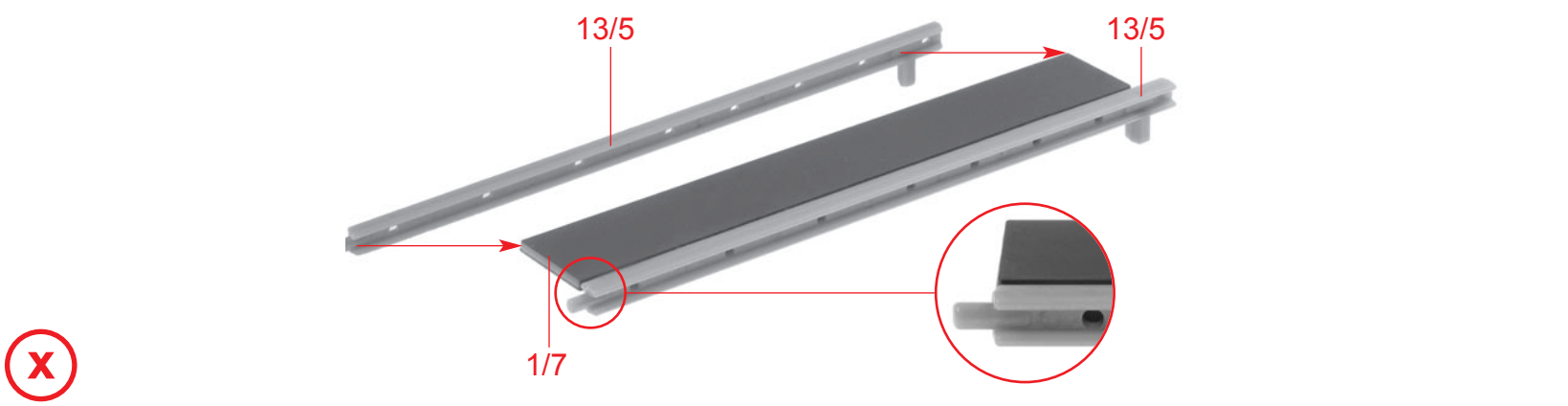
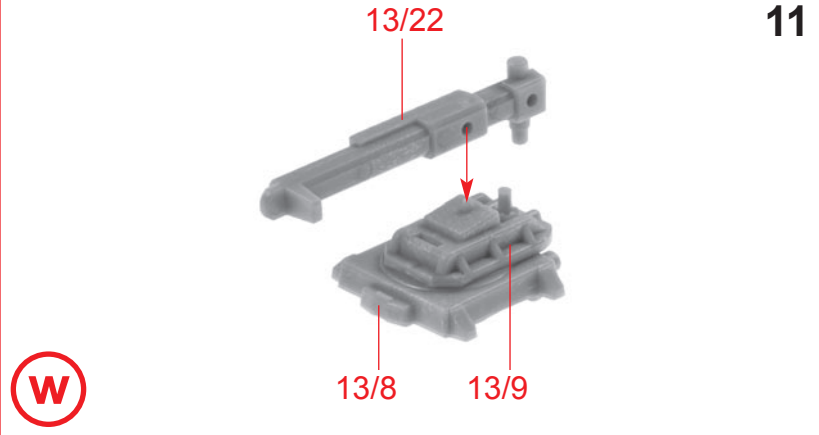
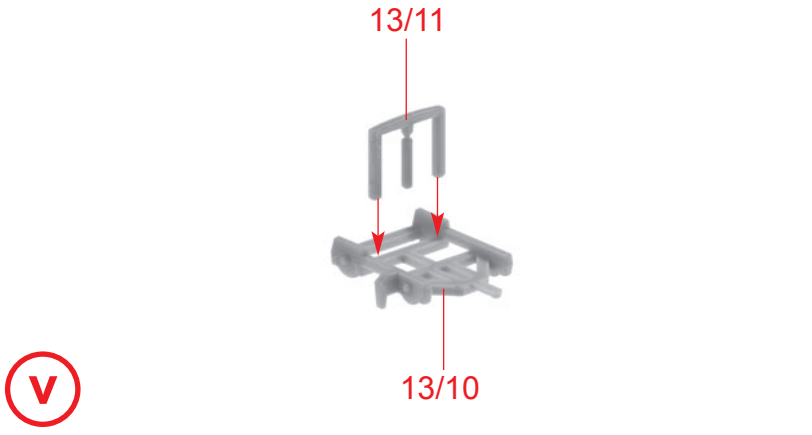

13/12 13/12

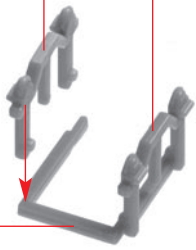

(A) 2 x 13/13

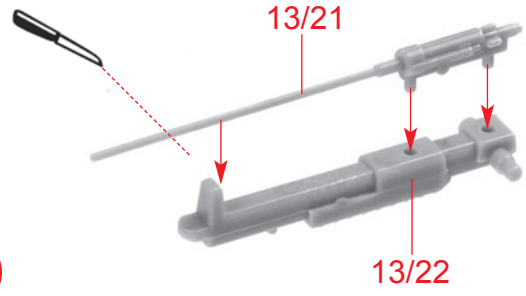

(B)

13/22

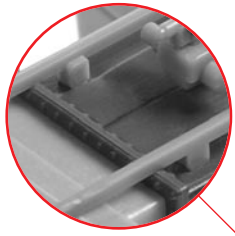

13/6

13/6

13/7

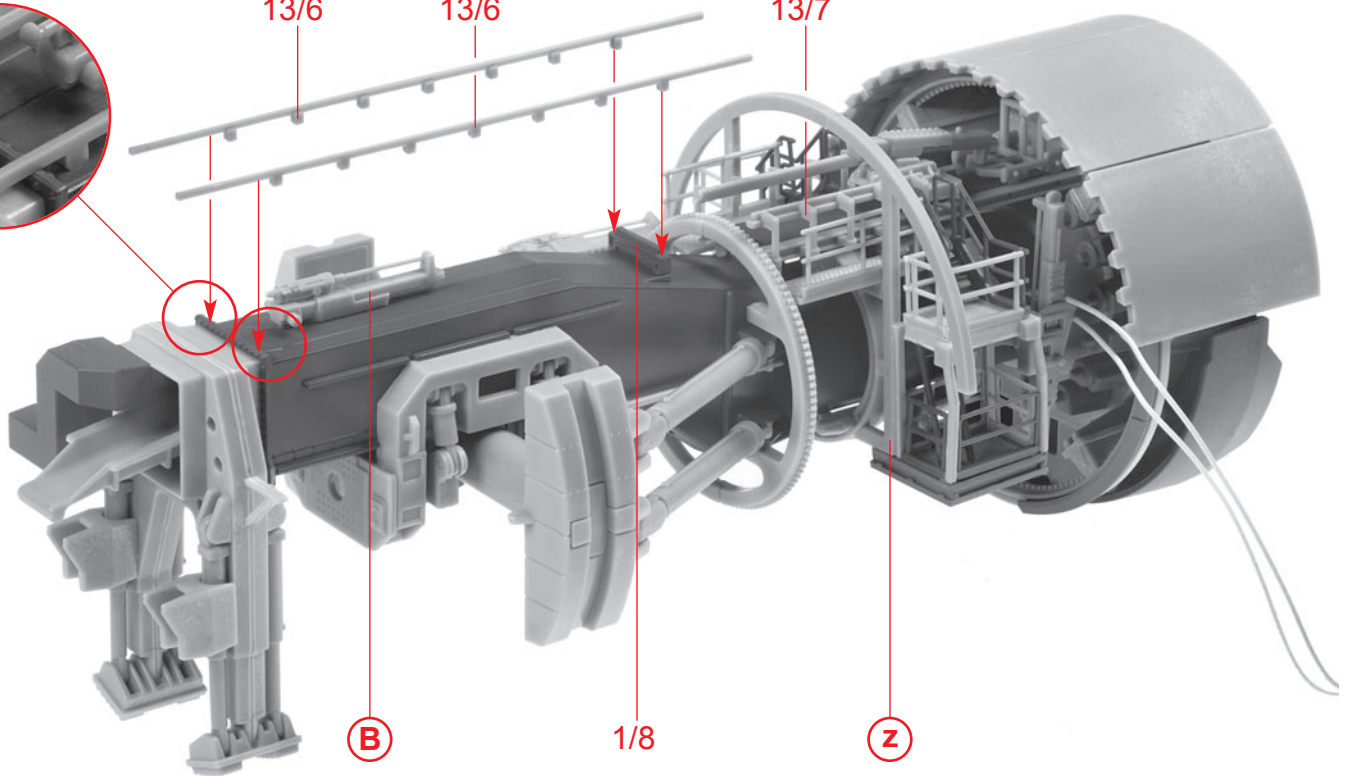

(C)

(B)

1/8

(Z)

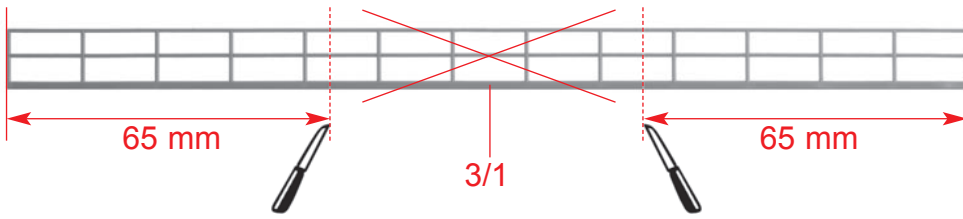

(D)

65 mm

3/1

65 mm

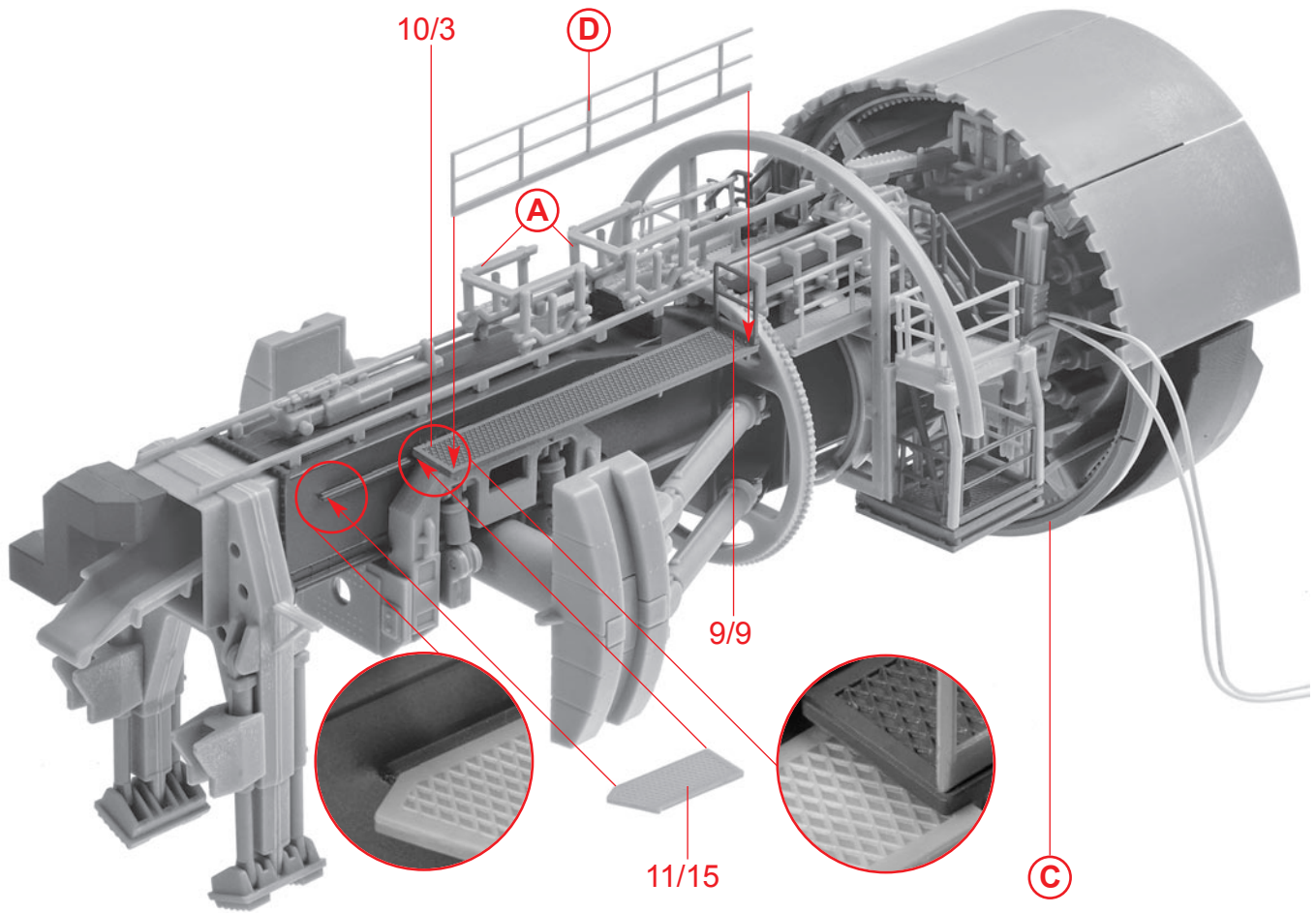

(E)

10/3

(D)

(A)

9/9

11/15

(C)

F

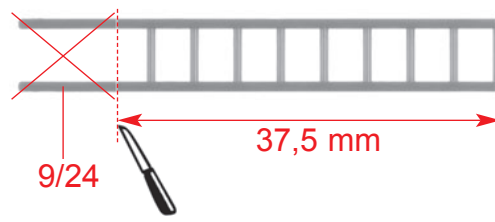

G

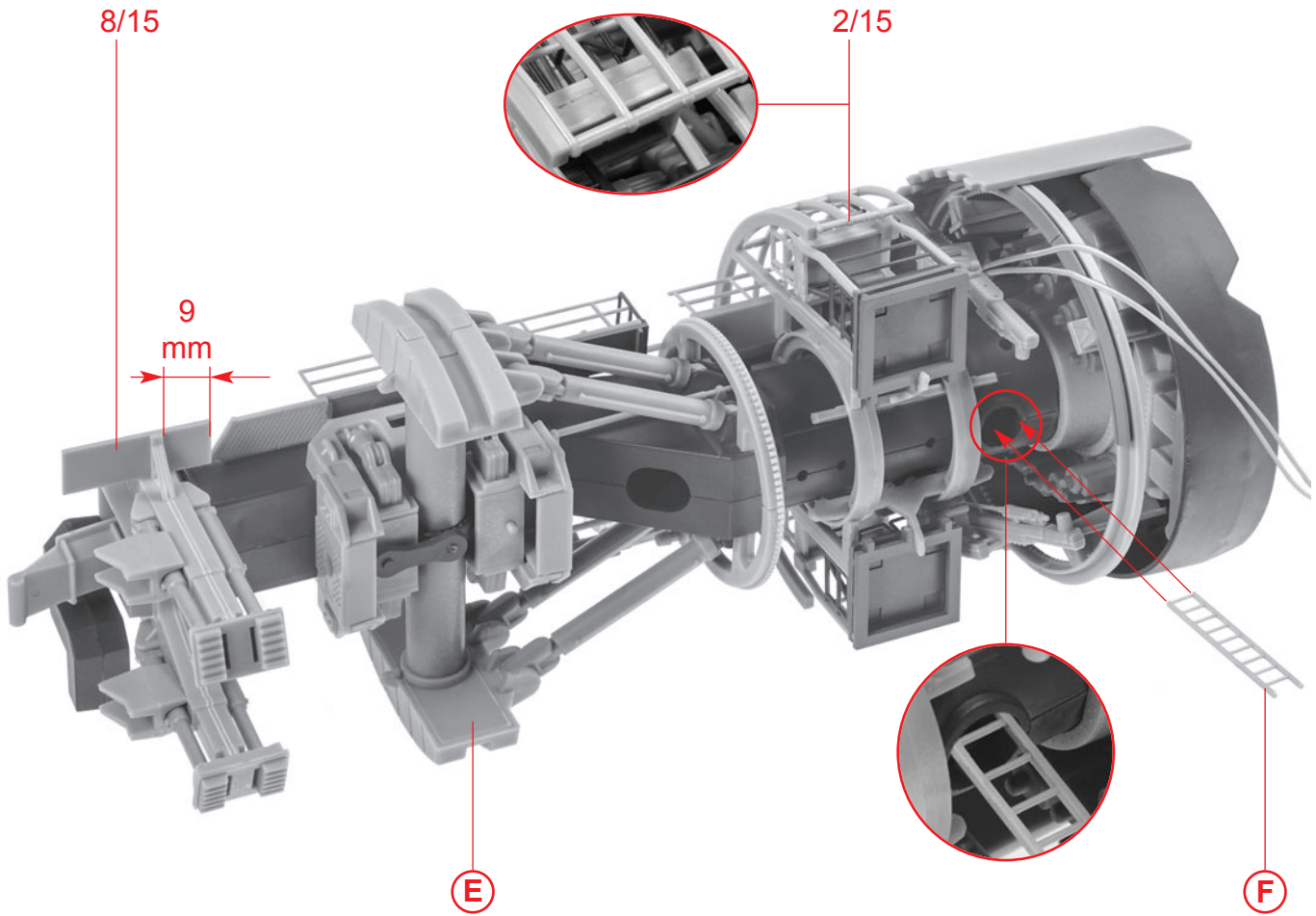

H

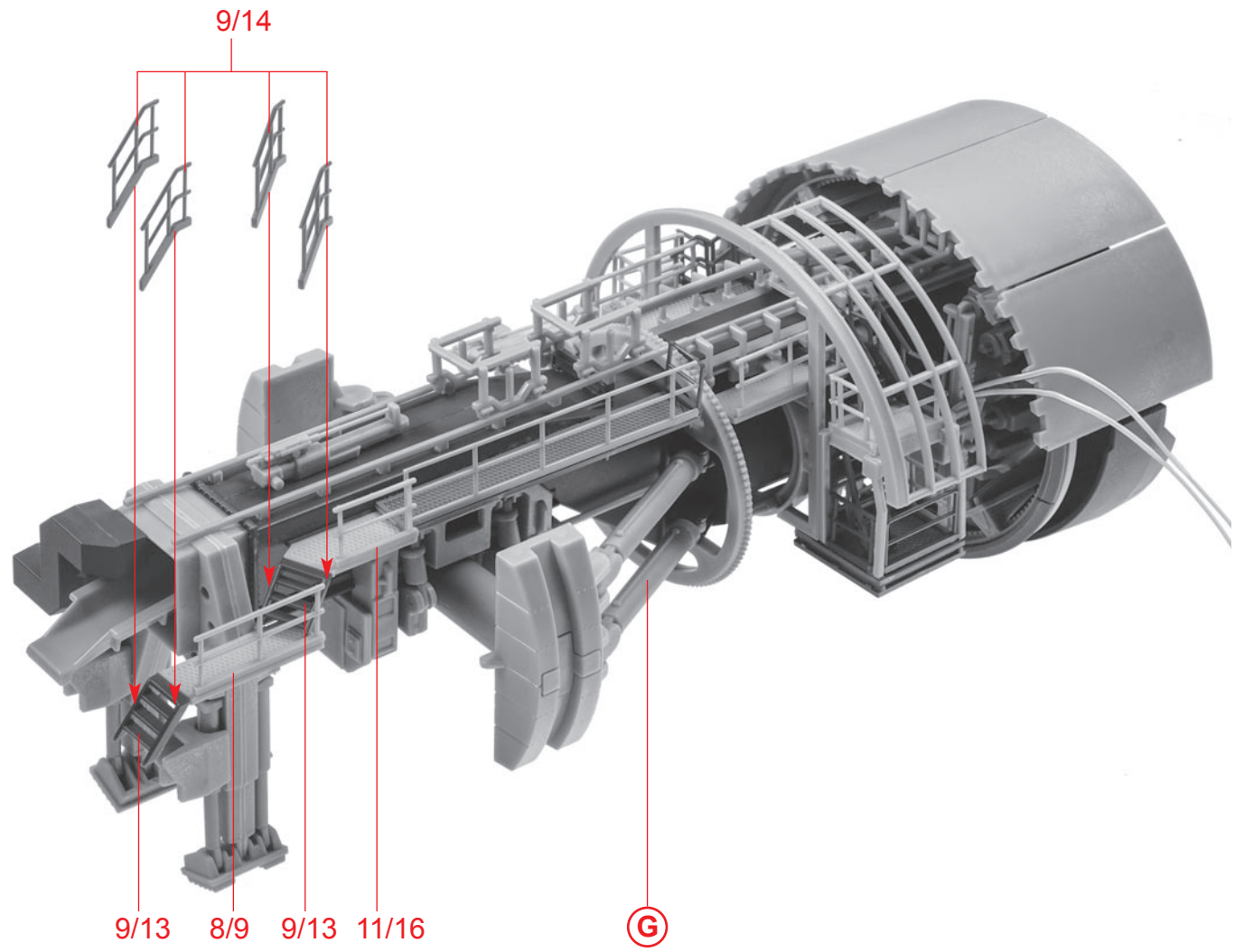

I

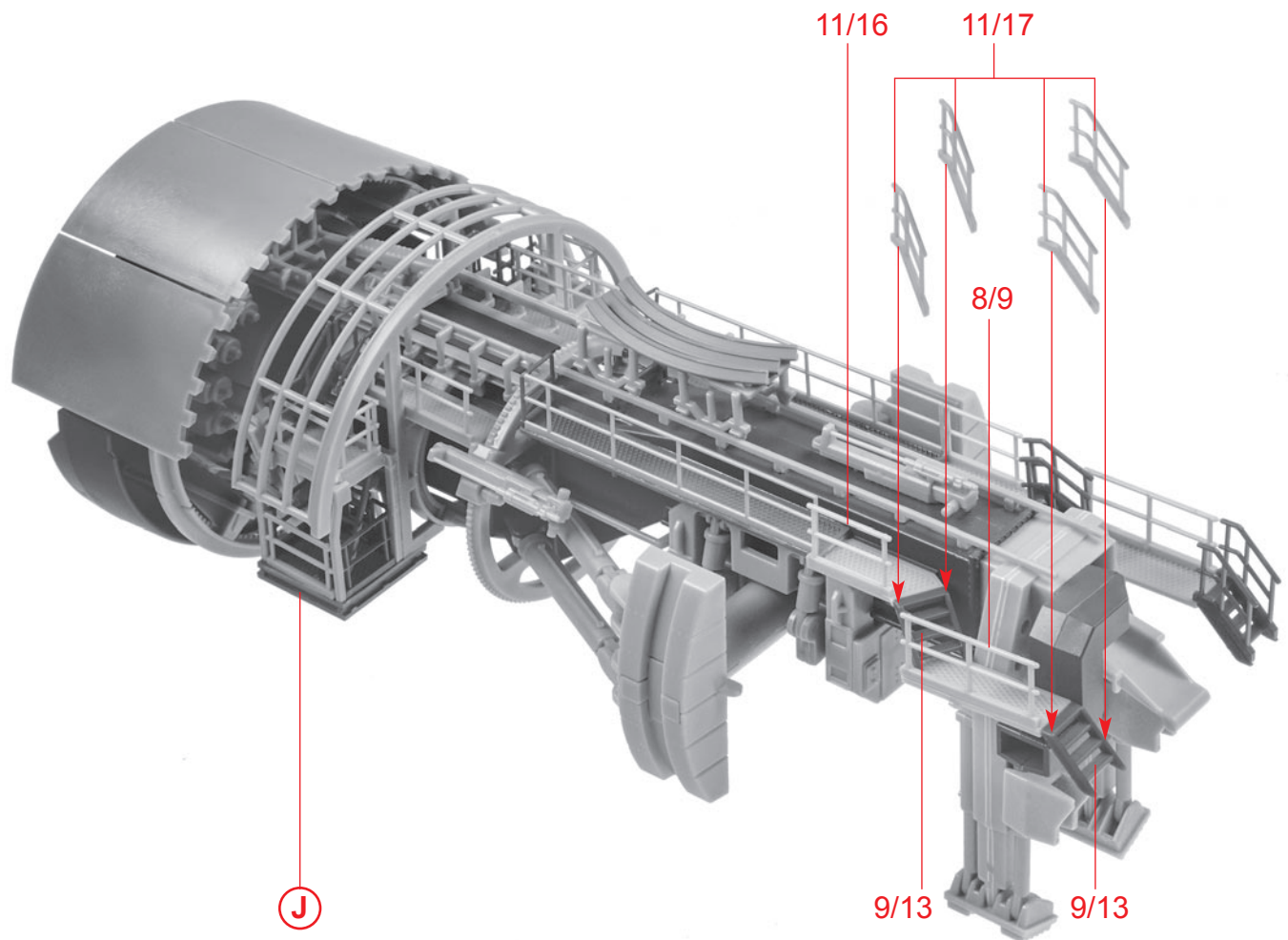
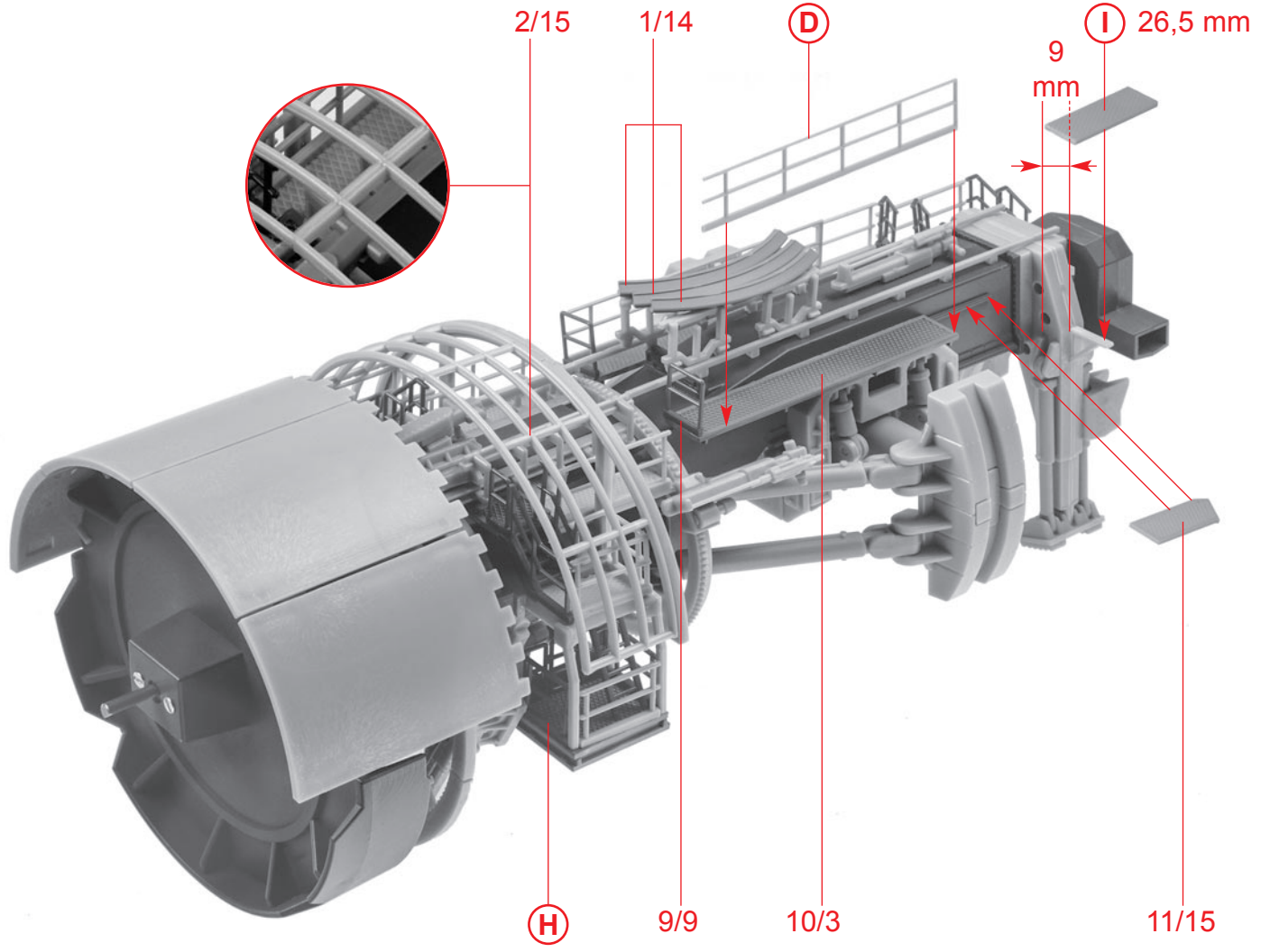
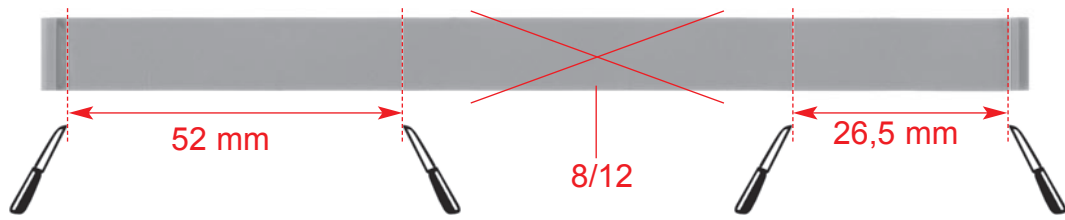

Mit Sekundenkleber fixieren!
Secure with instant modelling cement!
Fixez avec de la colle rapide !
Zet vast met secondenlijm!

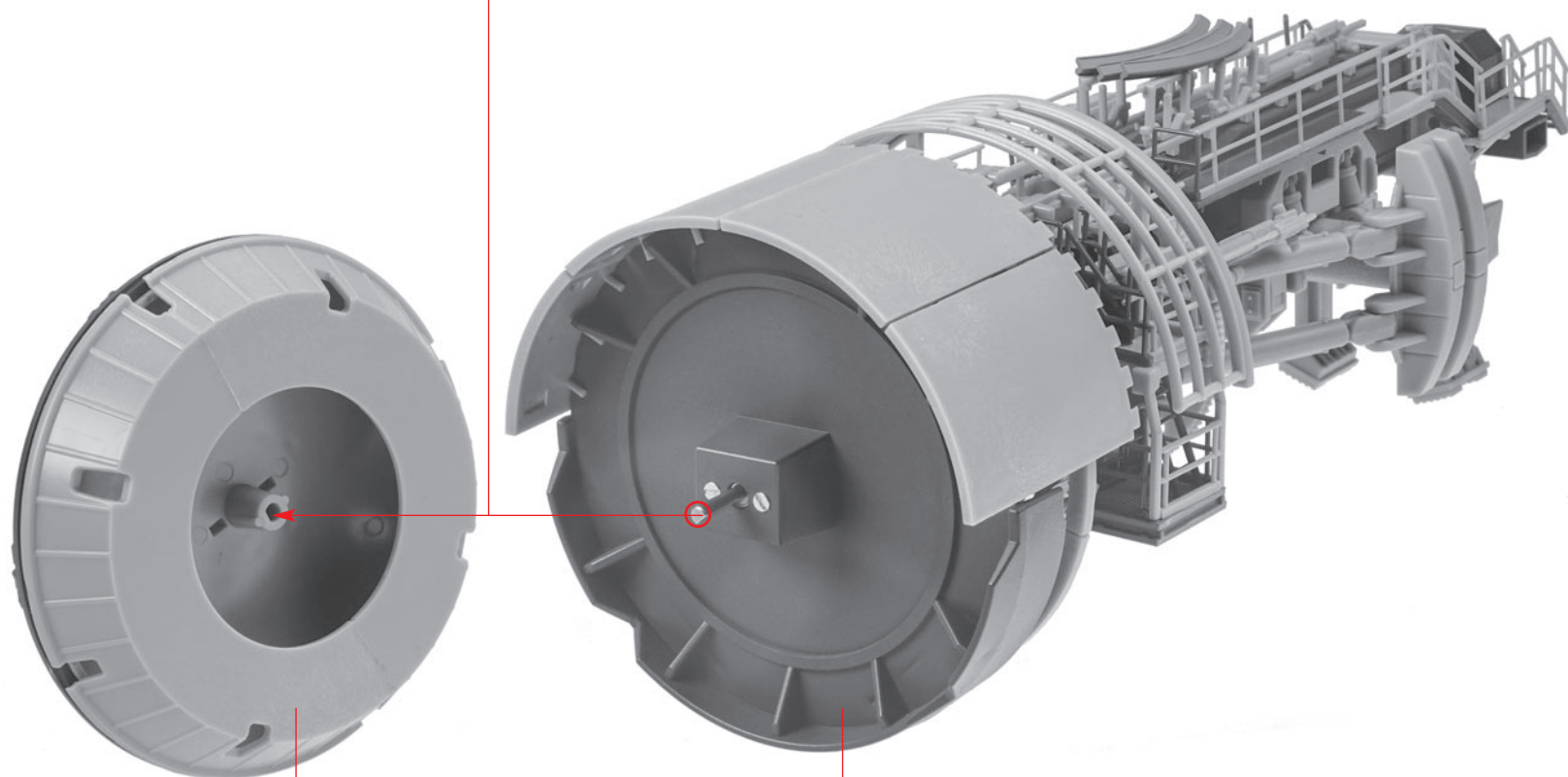

L

D

K

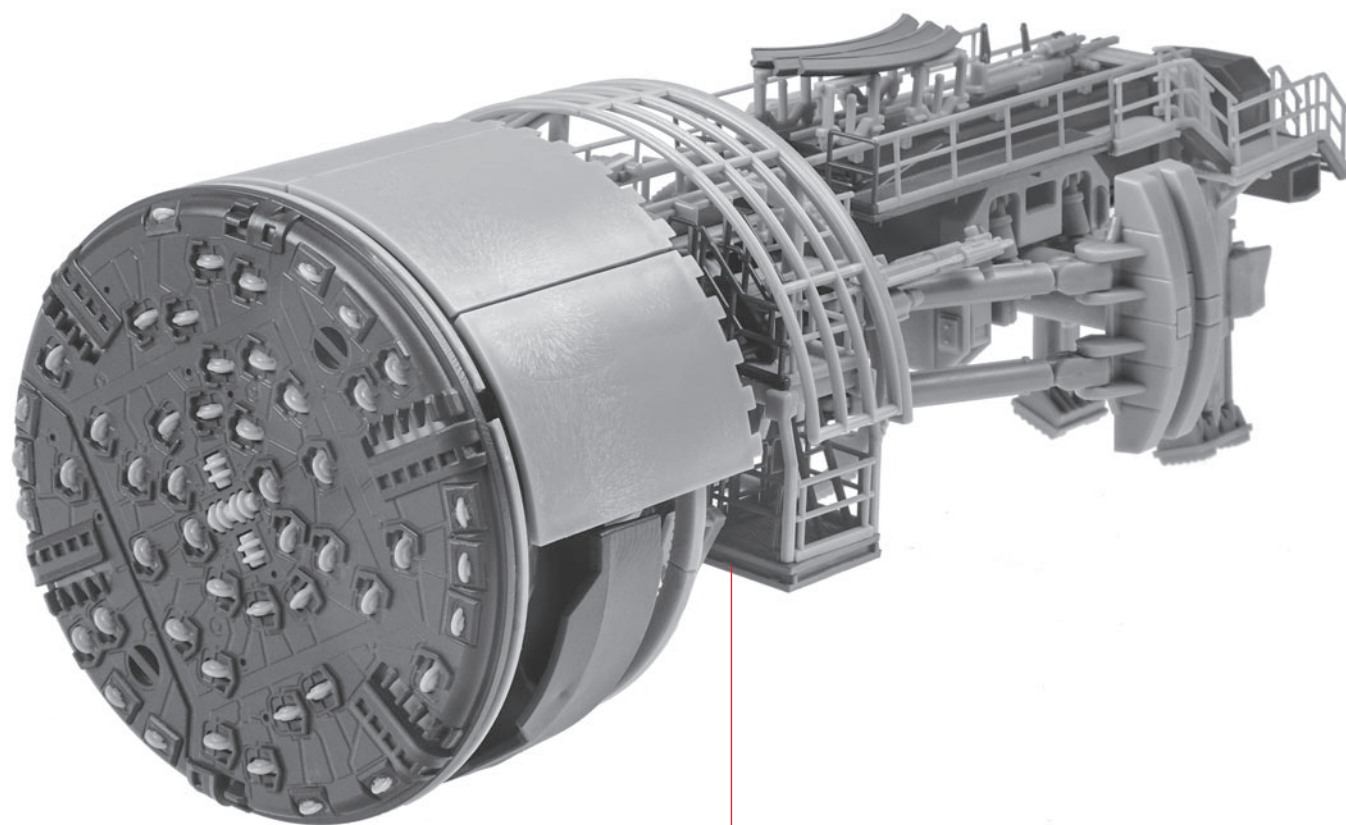

M

L



A

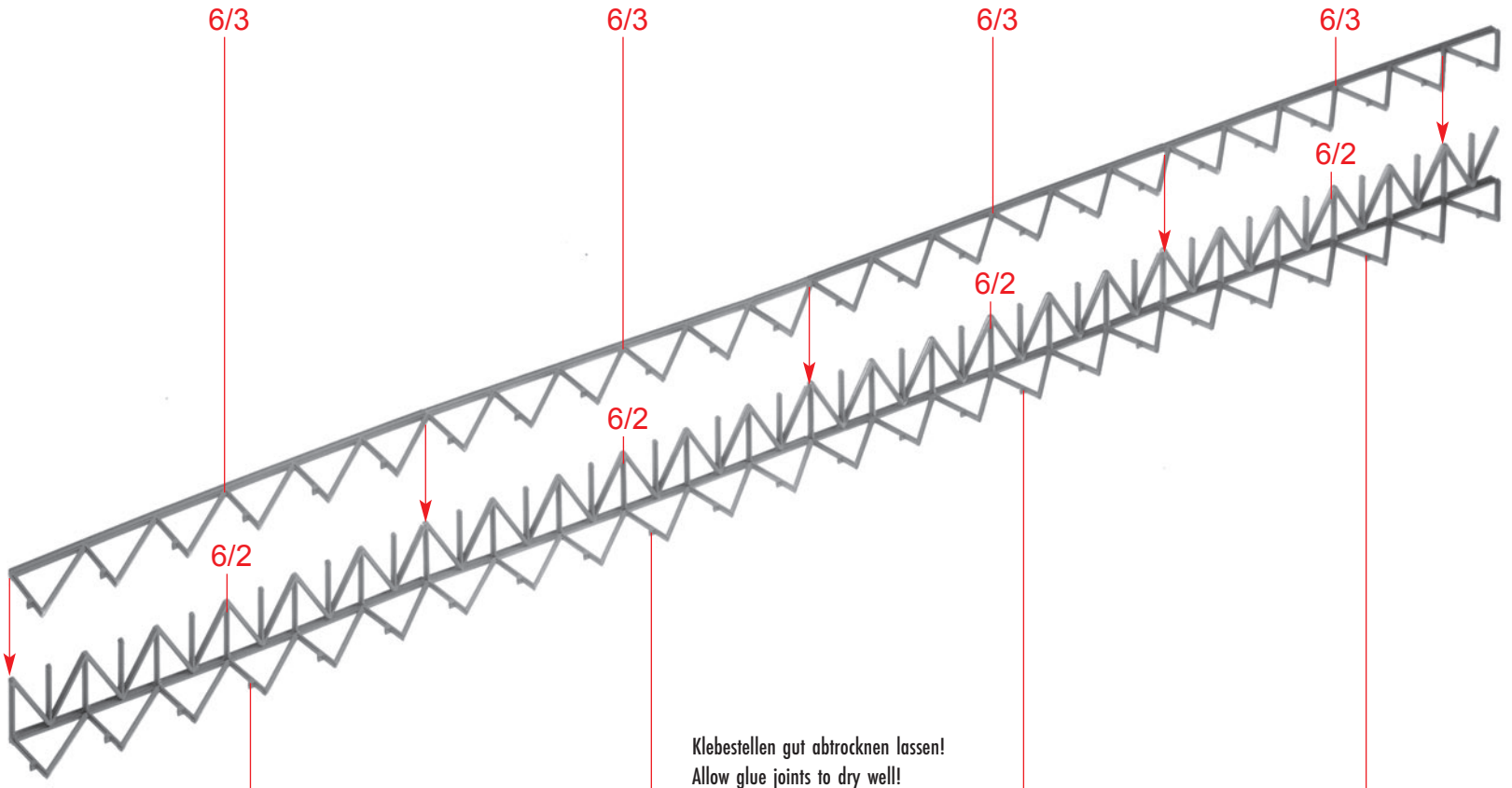

B

Klebestellen gut abtrocknen lassen!
 Allow glue joints to dry well!
 Laisser bien sécher les points de collage!
 Alle gelijmde punten goed laten drogen!

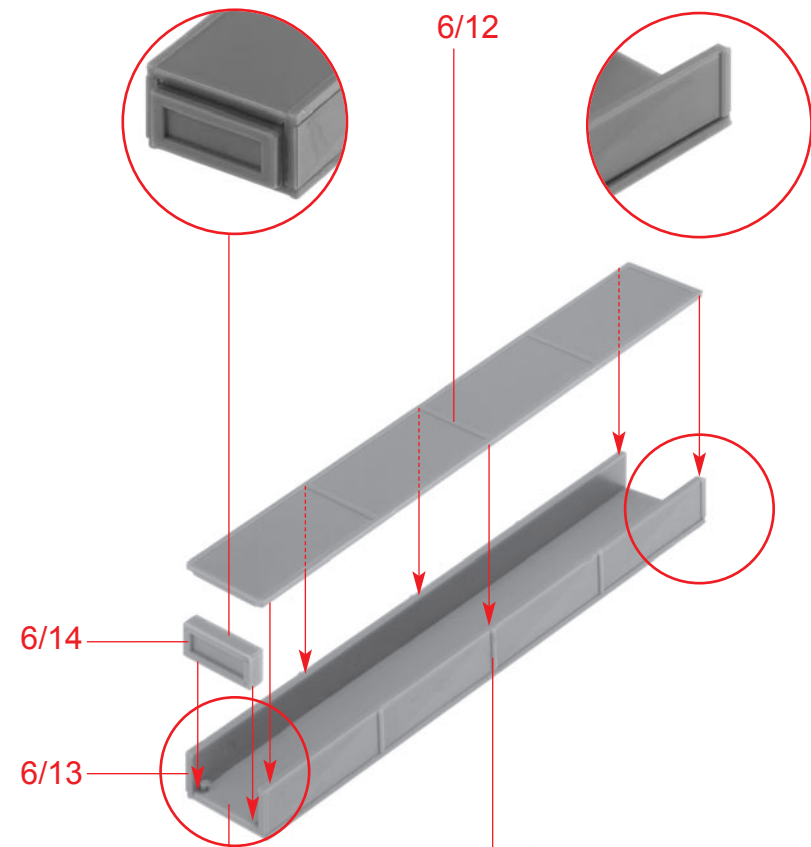

C

8 x

6/12

6/13

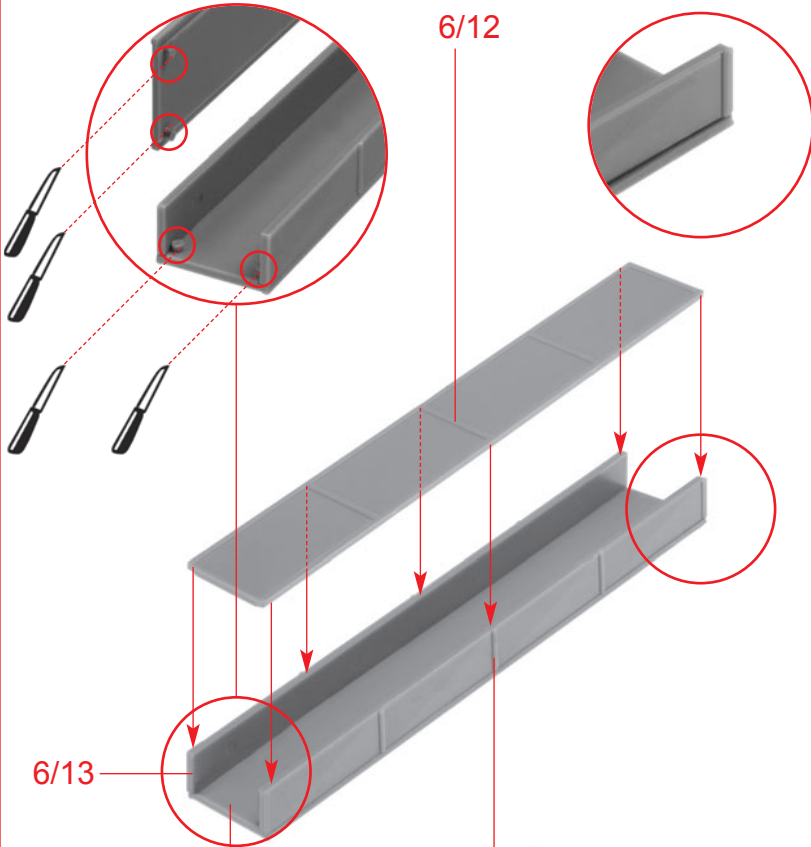

D

2 x

6/12

6/13

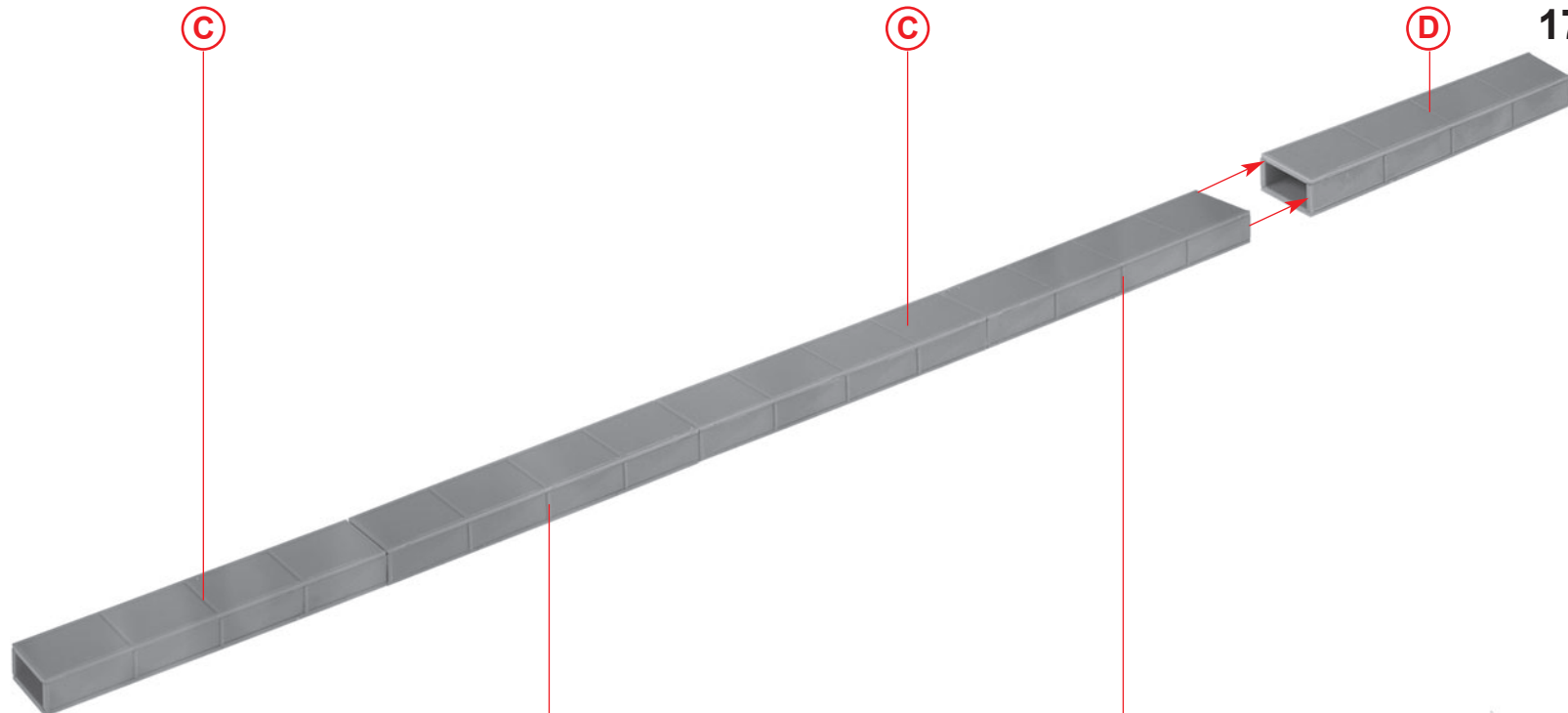

E 2 x

C

C

E

B

E

Bündig kleben!
 Glue flush!
 Colle à ras !
 Lijm doorspoelen!

Bündig kleben!
 Glue flush!
 Colle à ras !
 Lijm doorspoelen!

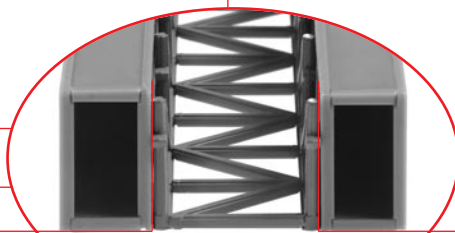
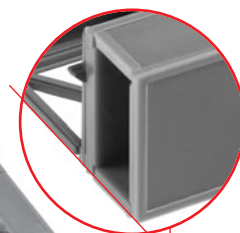
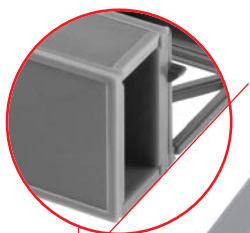

90°

90°

F

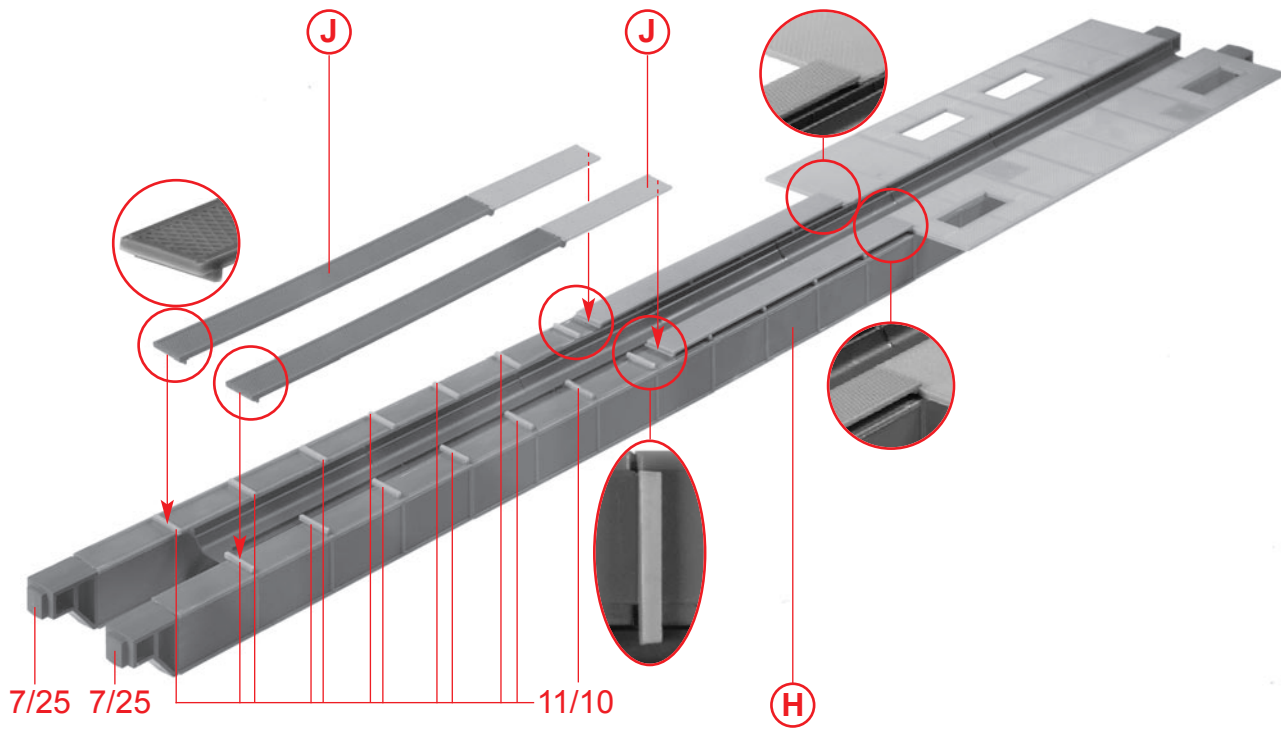
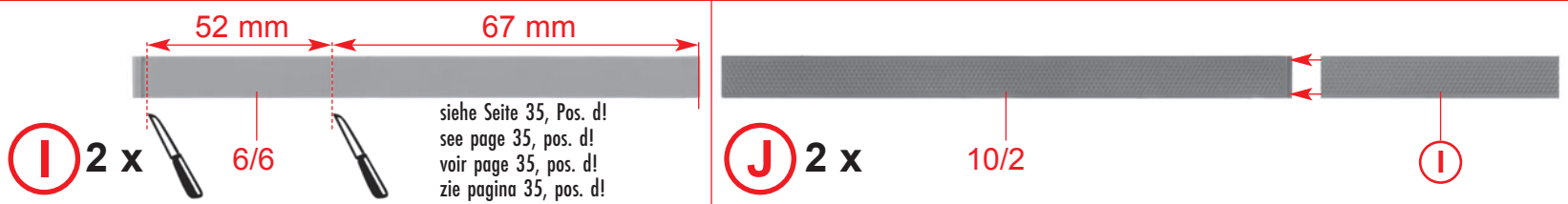
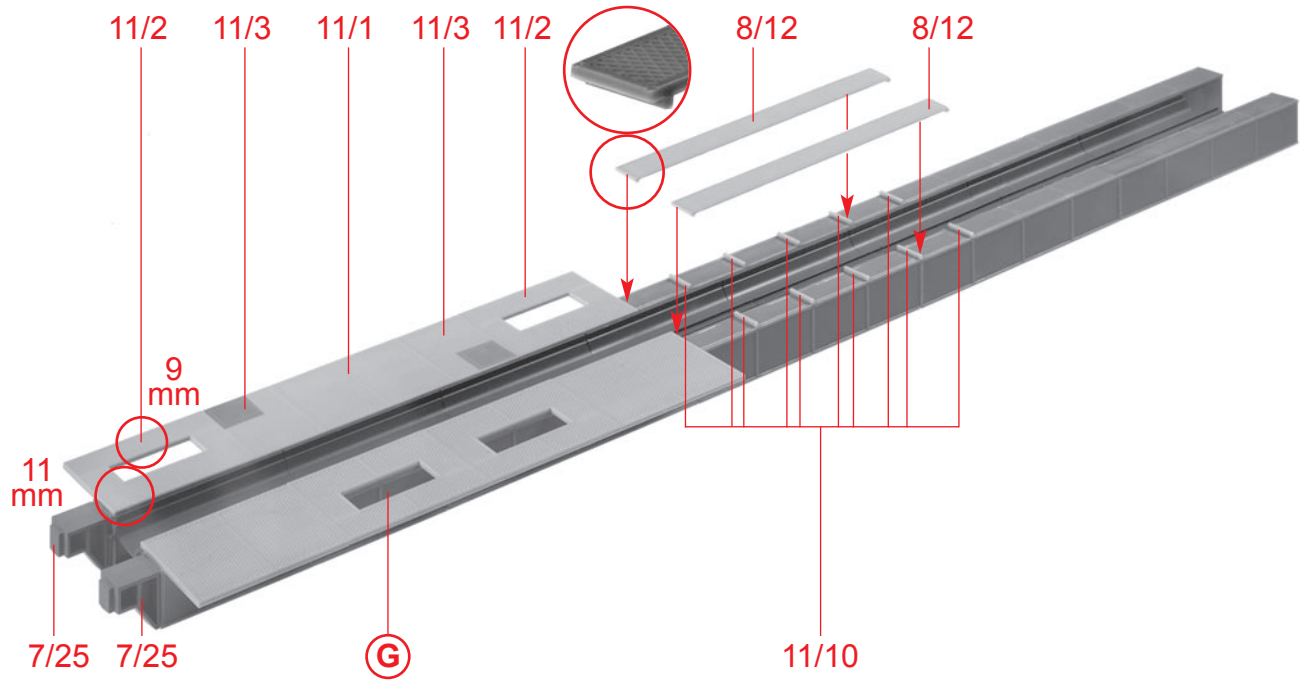
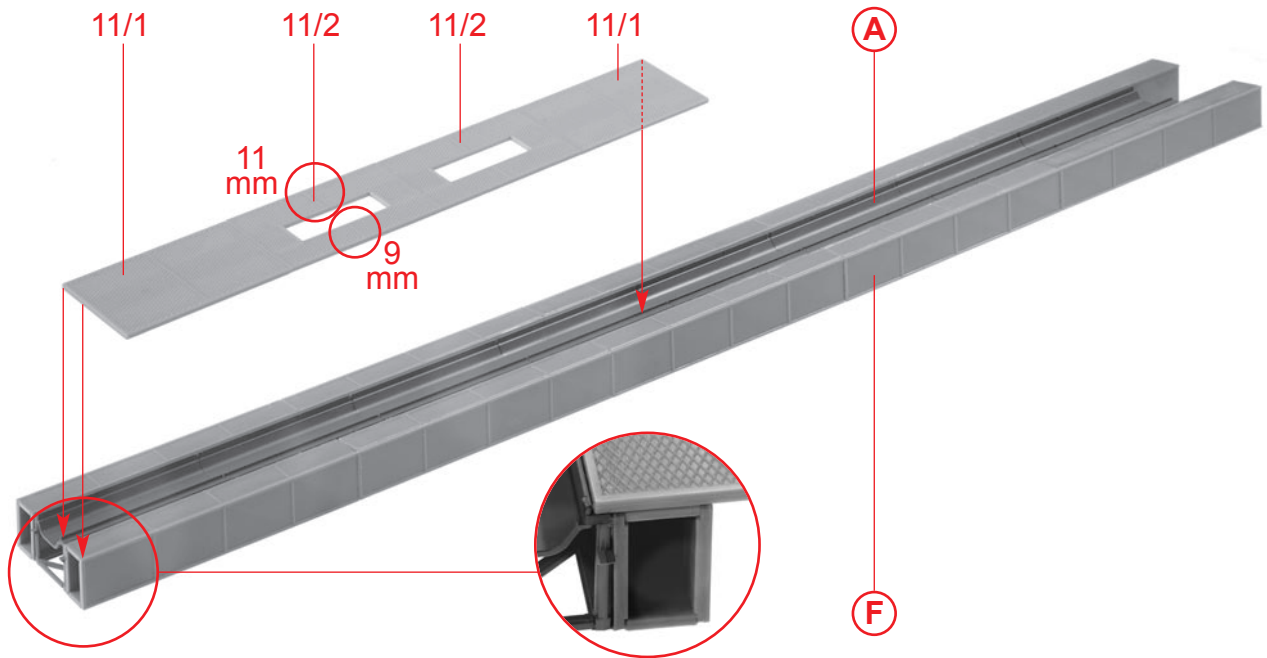

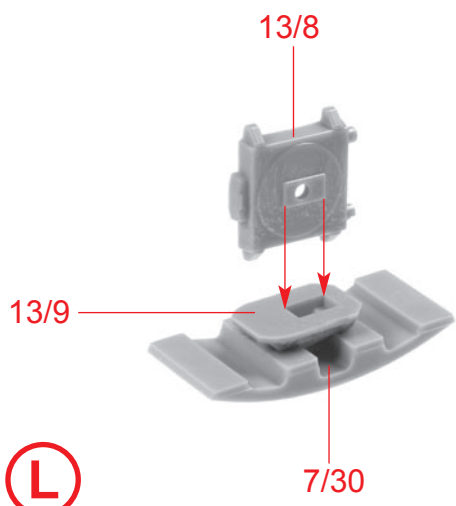

L

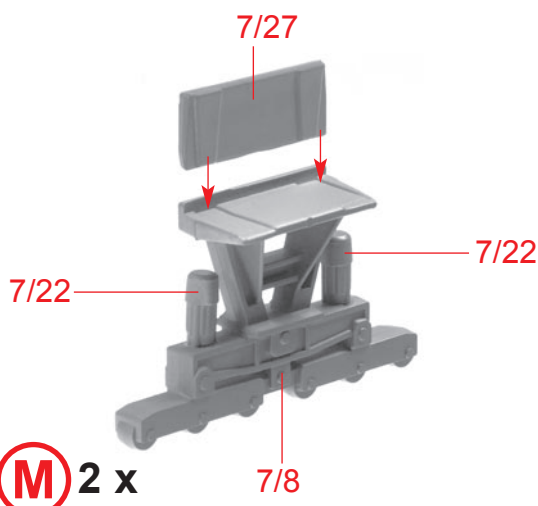

M 2 x

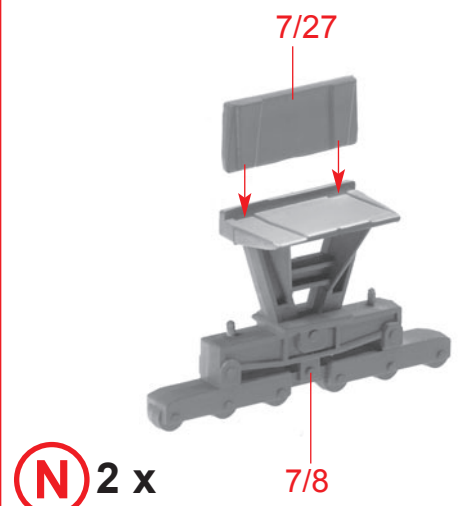

N 2 x

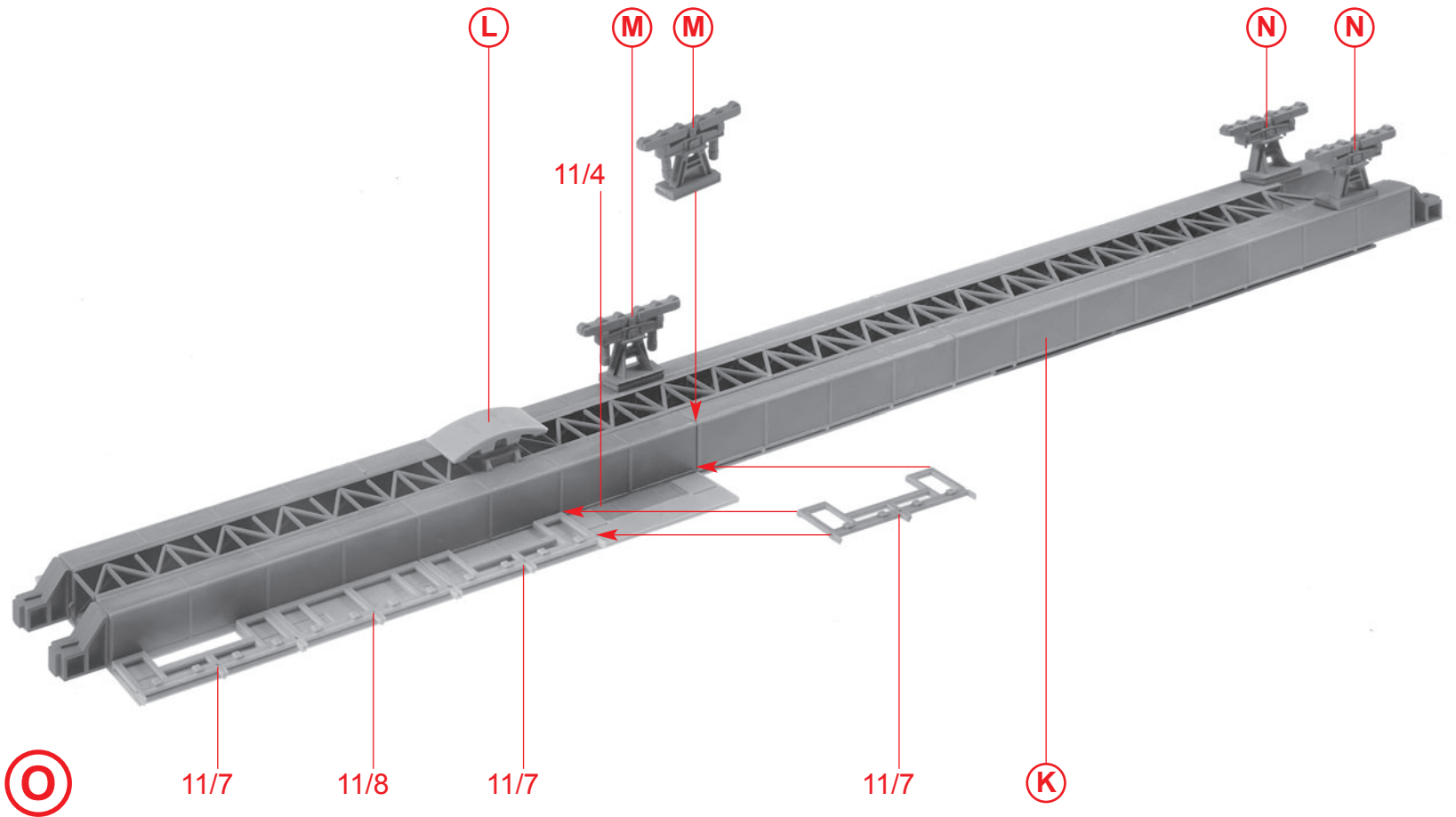

O

11/7

11/8

11/7

11/7

K

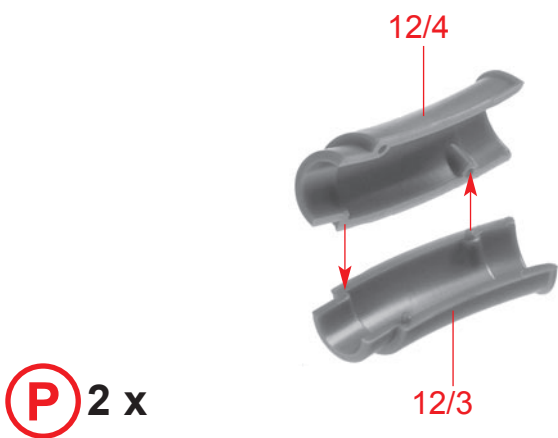

P 2 x

12/4

12/3

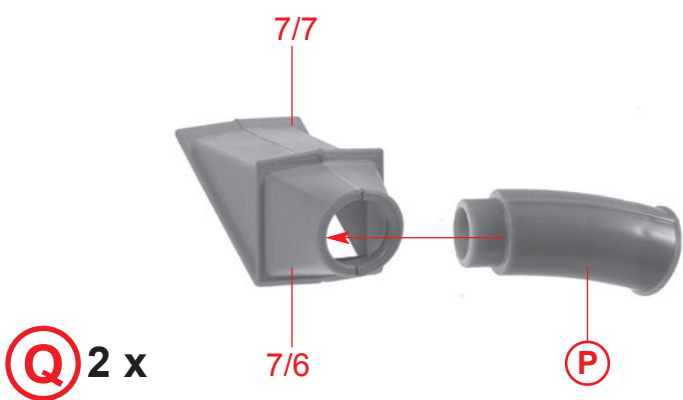

Q 2 x

7/7

7/6

P

R 7 x

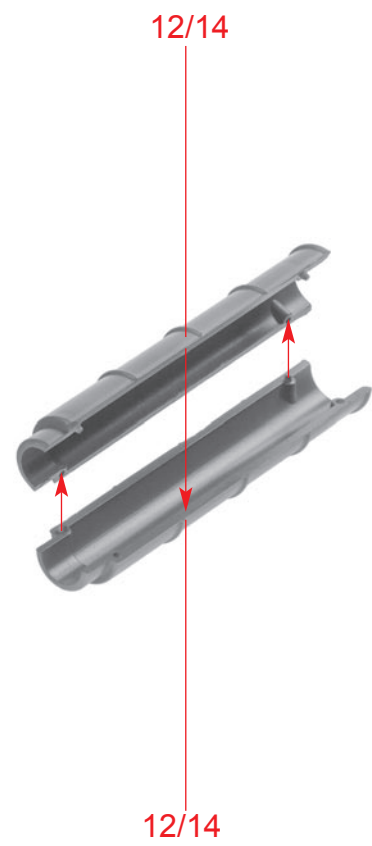

12/14

12/14

S

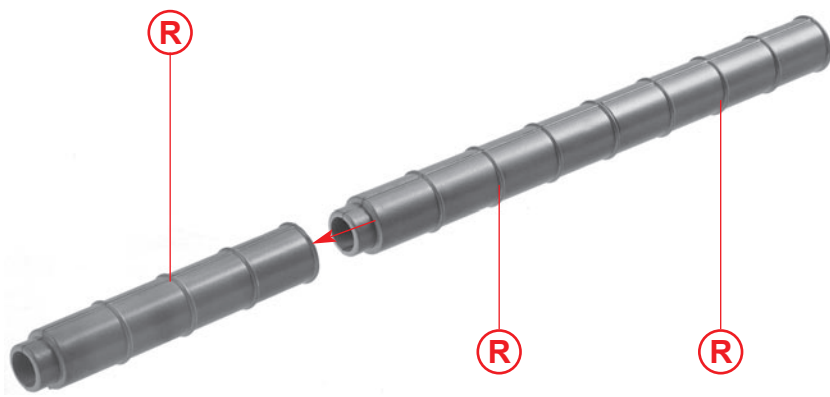

T

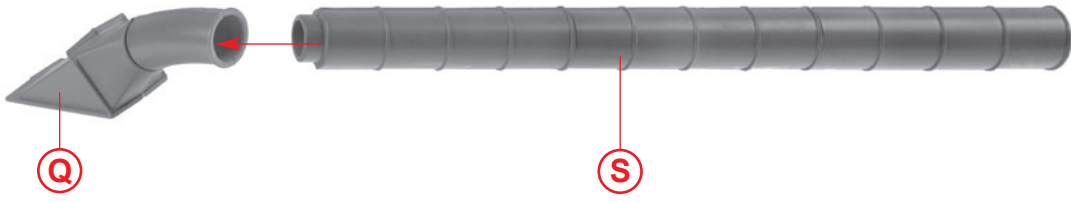

U

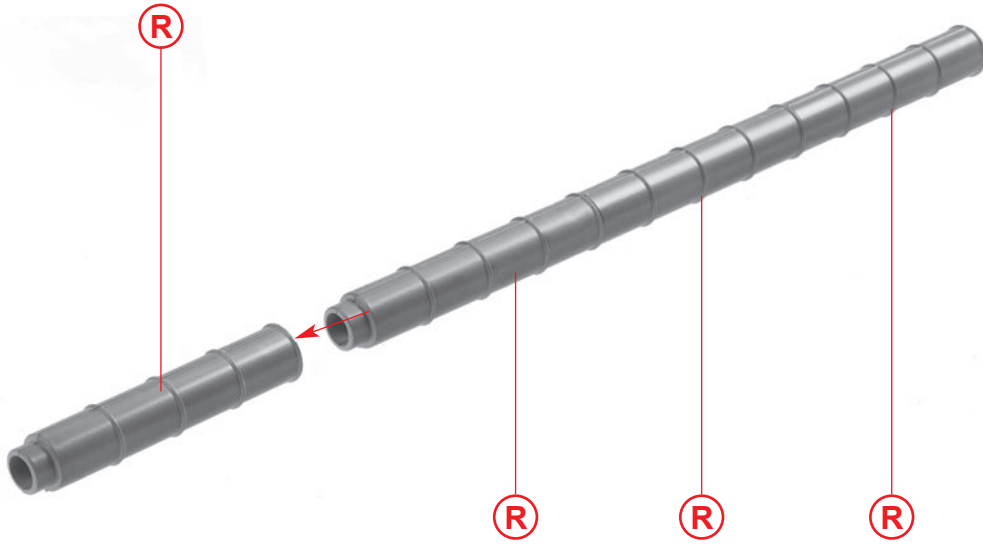

V

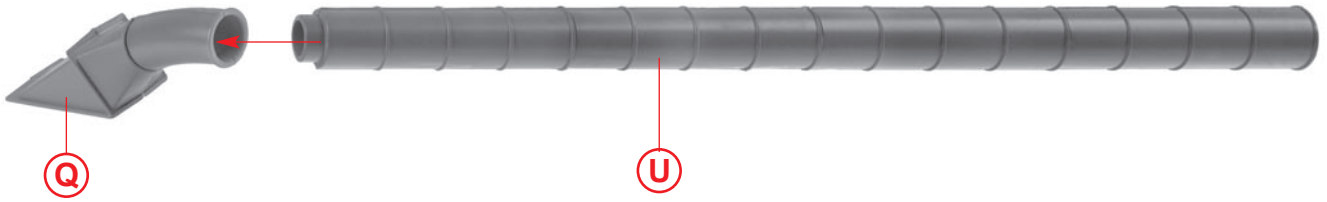

W

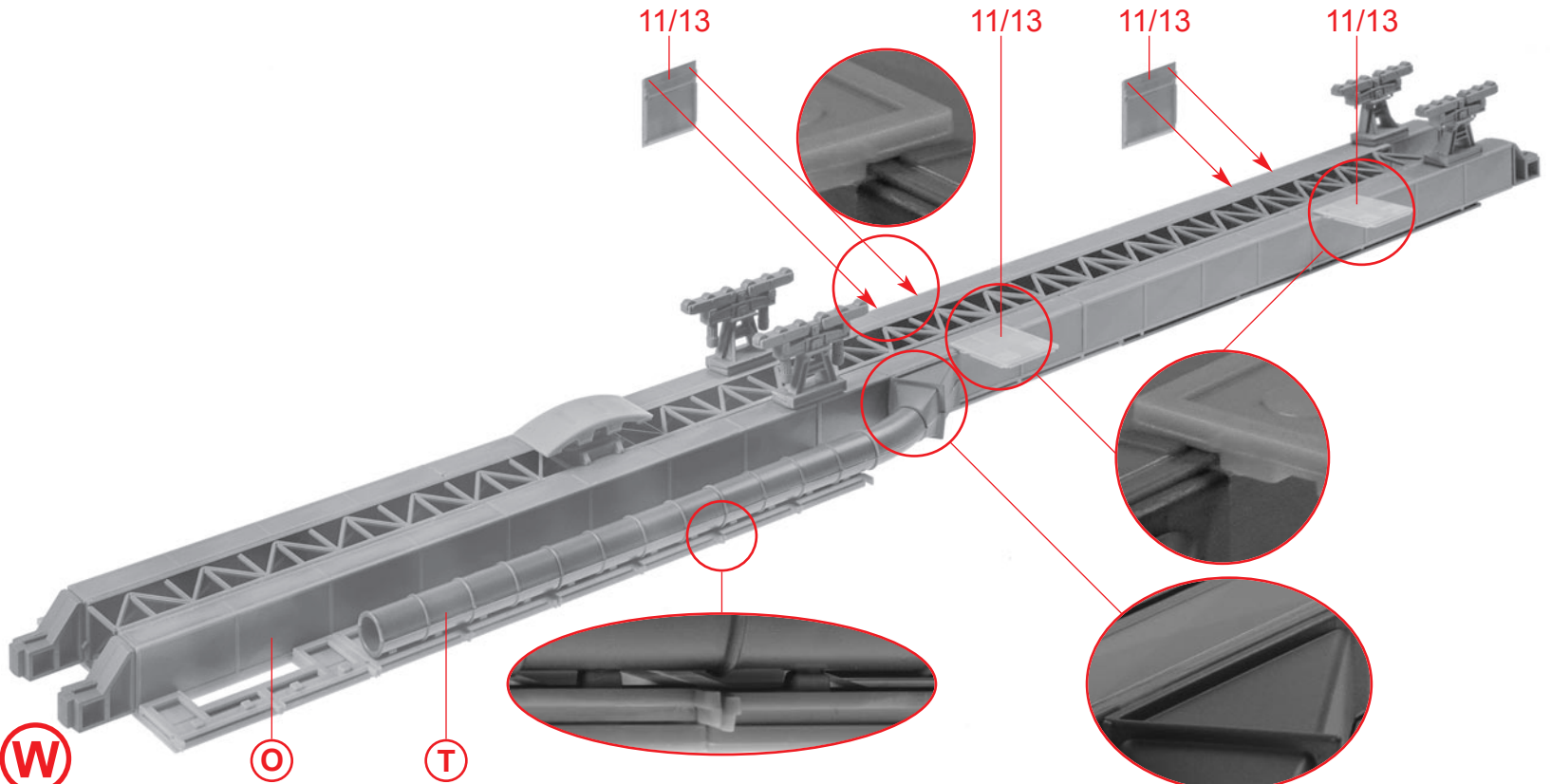

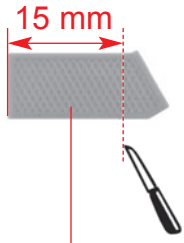

(X)

11/15

11/17 11/17

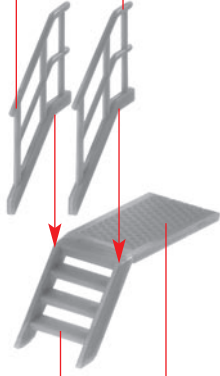

(Y)

11/19

(X)

(Y)

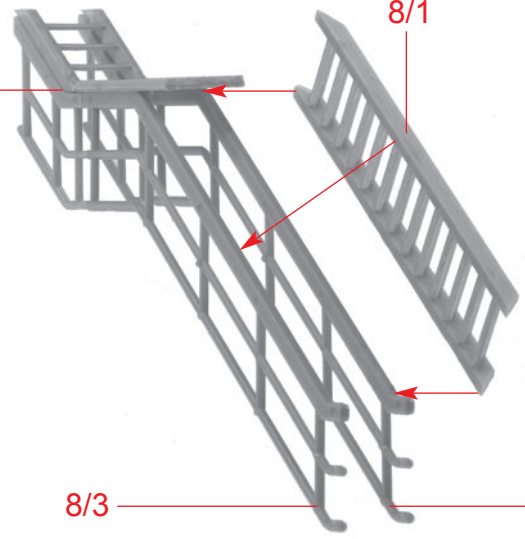

8/1

(Z)

8/3

8/3

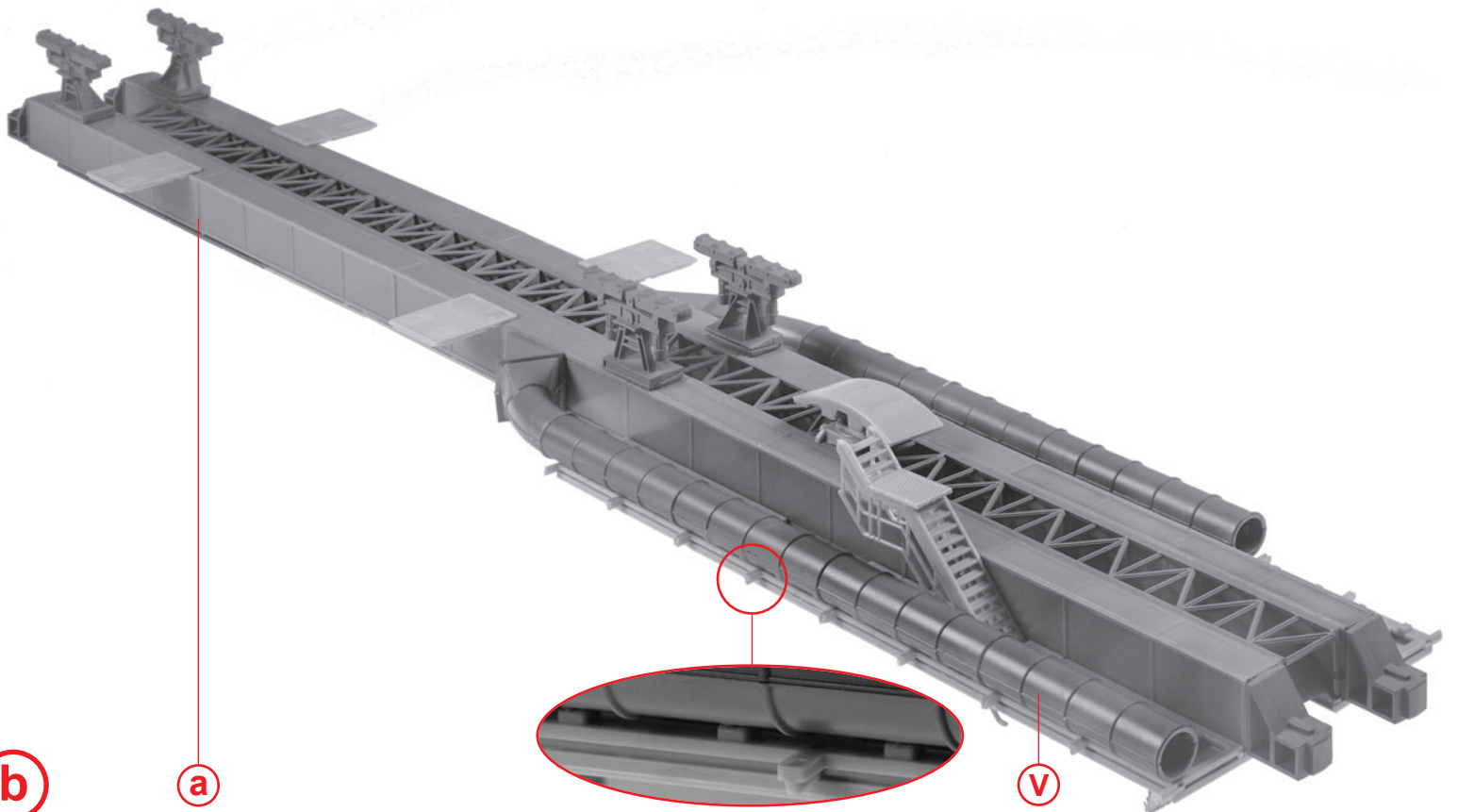
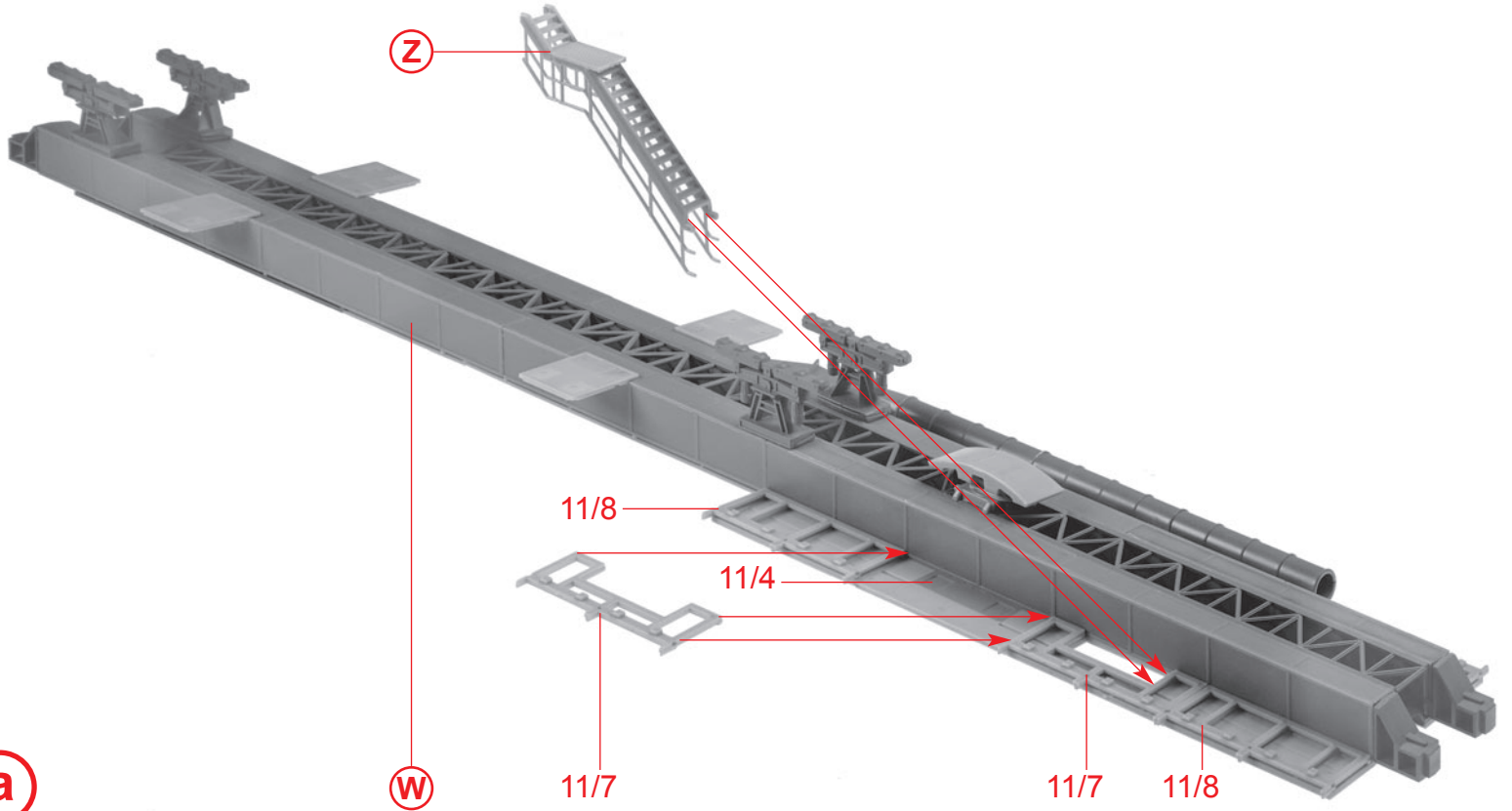

11/25

11/27

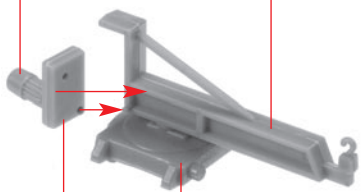

c

11/24

13/8

d

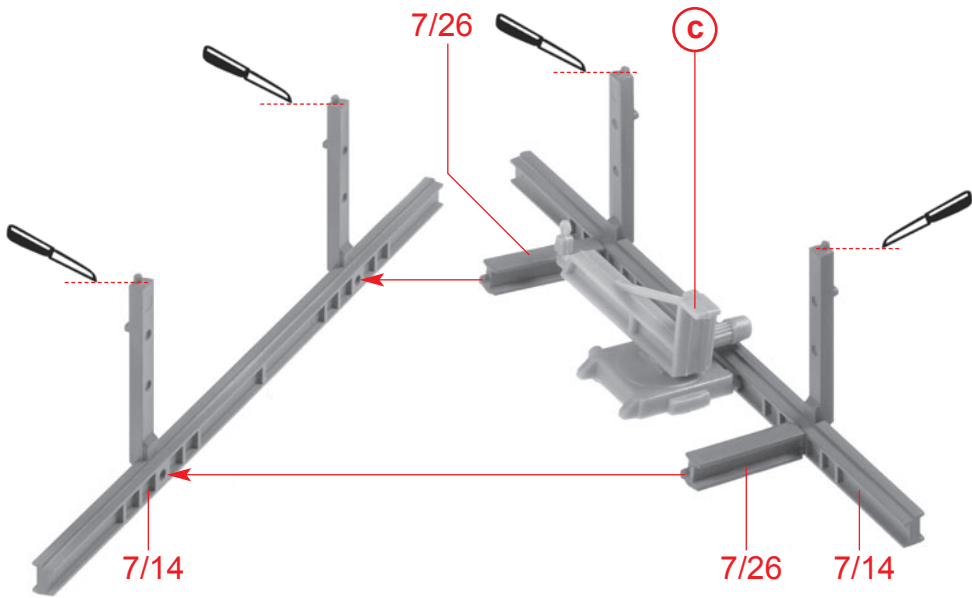

7/14

7/26

c

7/26

7/14

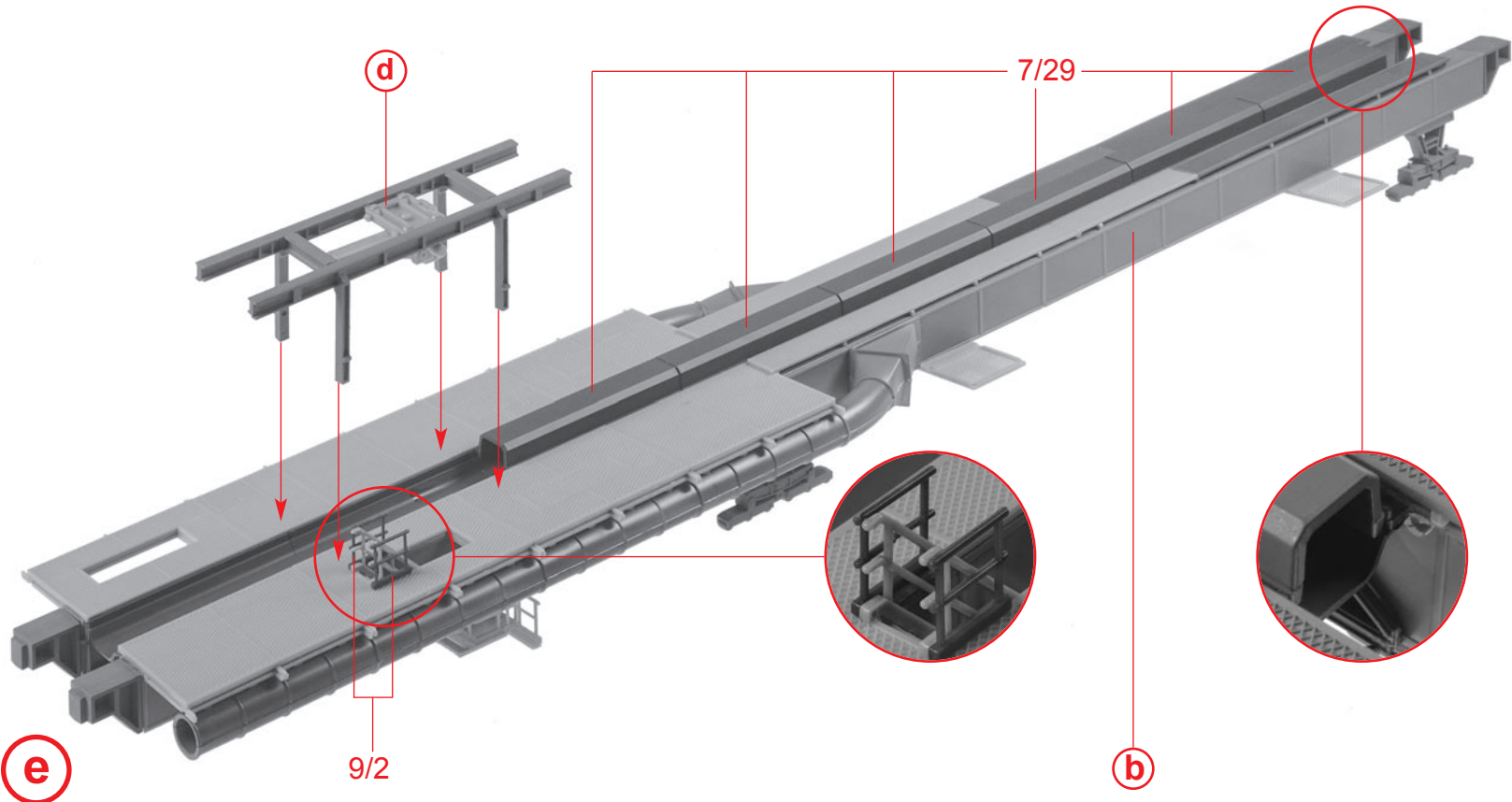

e

d

7/29

9/2

b

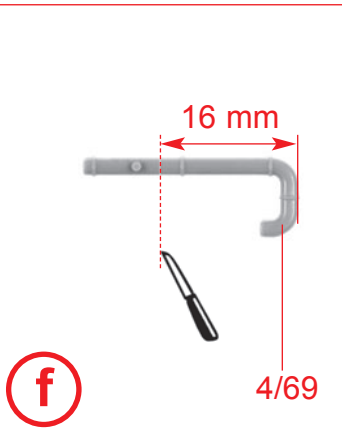

f

16 mm

4/69

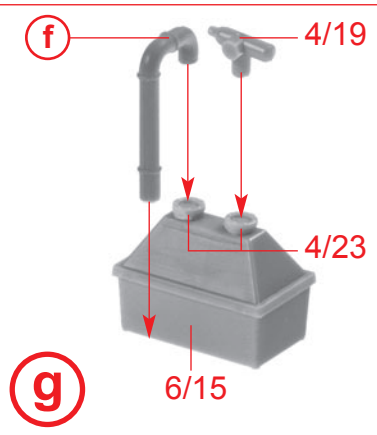

g

6/15

4/19

4/23

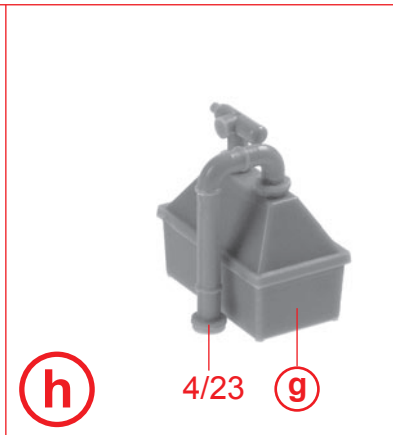

h

4/23

g

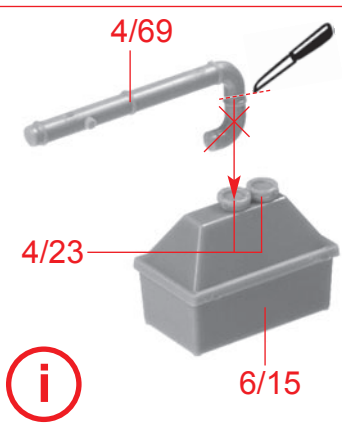

i

4/69

4/23

6/15

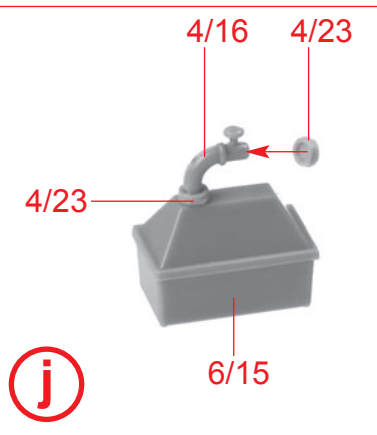

j

4/16

4/23

6/15

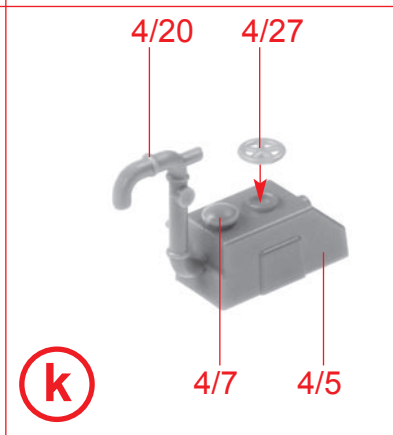

k

4/20

4/27

4/7

4/5

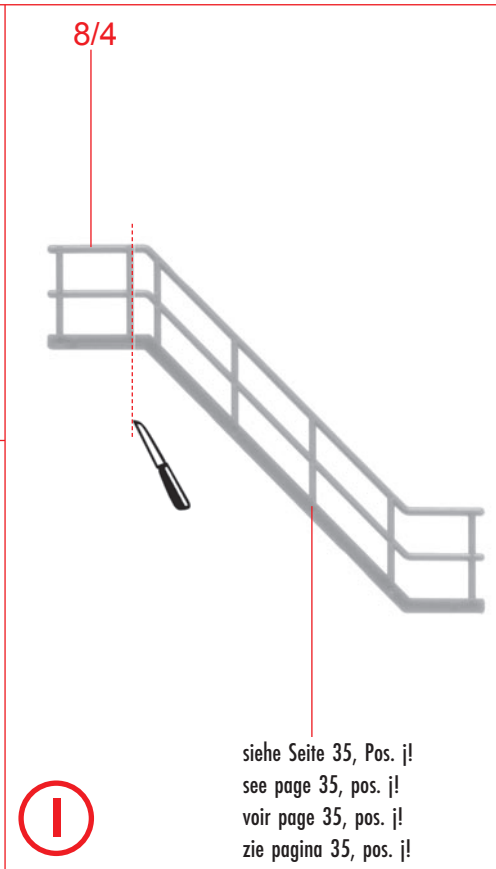

l

8/4

siehe Seite 35, Pos. j!
see page 35, pos. j!
voir page 35, pos. j!
zie pagina 35, pos. j!

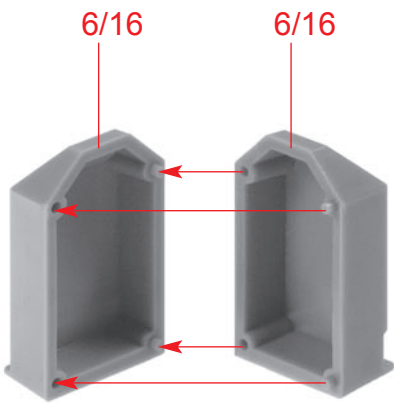
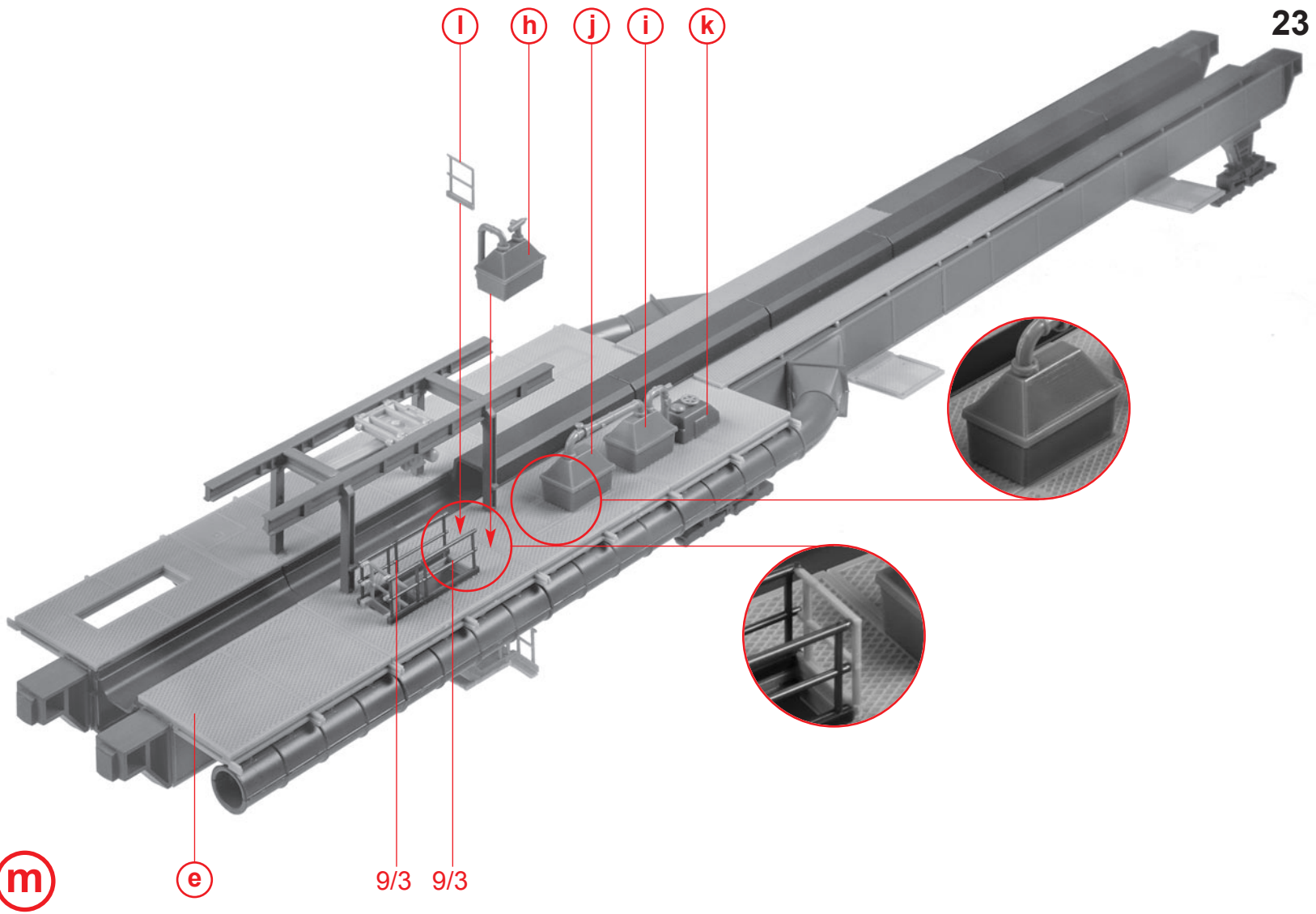

n 4 x

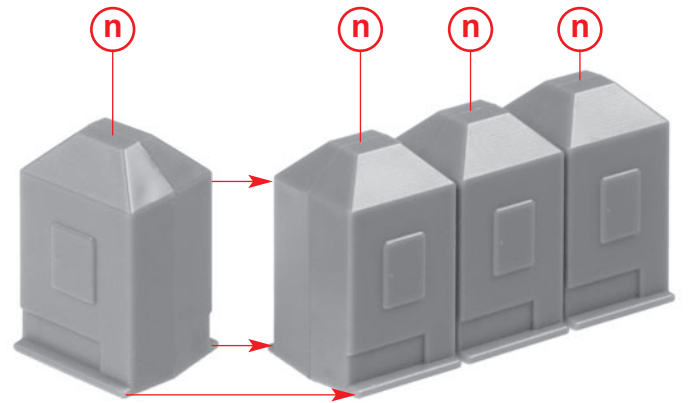

o

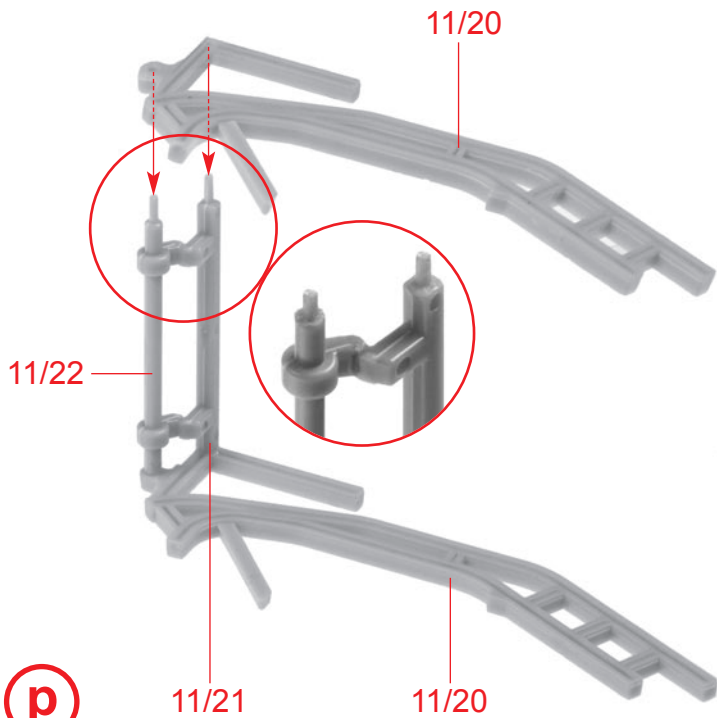

p

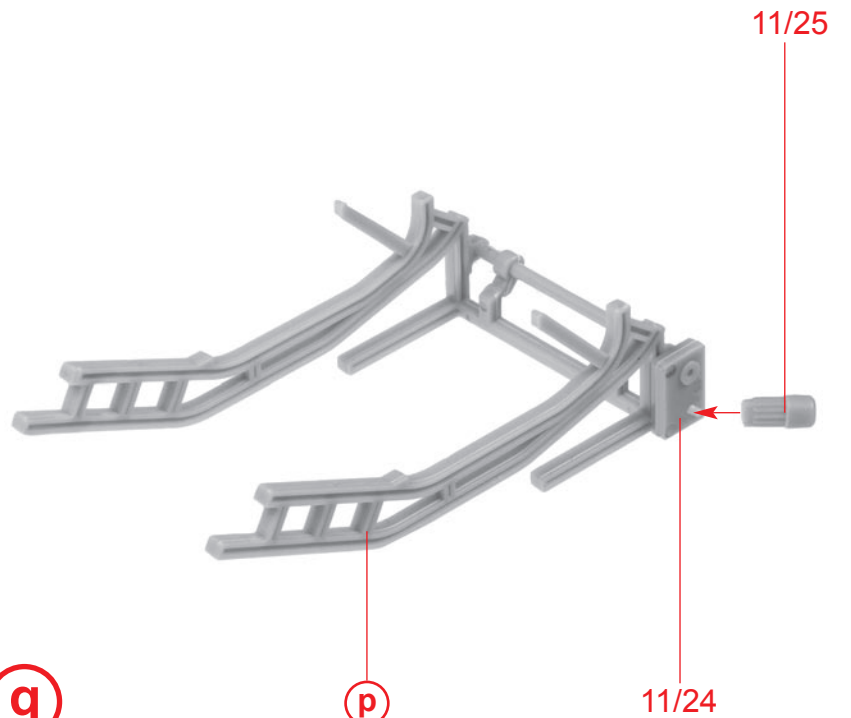

q

Fensterfolie
Window foil
Feuillet transparent
Vensterfolie

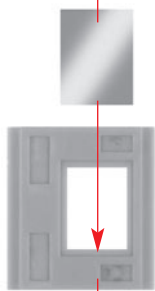

11/33

Fensterfolie
Window foil
Feuillet transparent
Vensterfolie



11/32

Deco 1



11/30

r

s

t

r

t

11/31

s

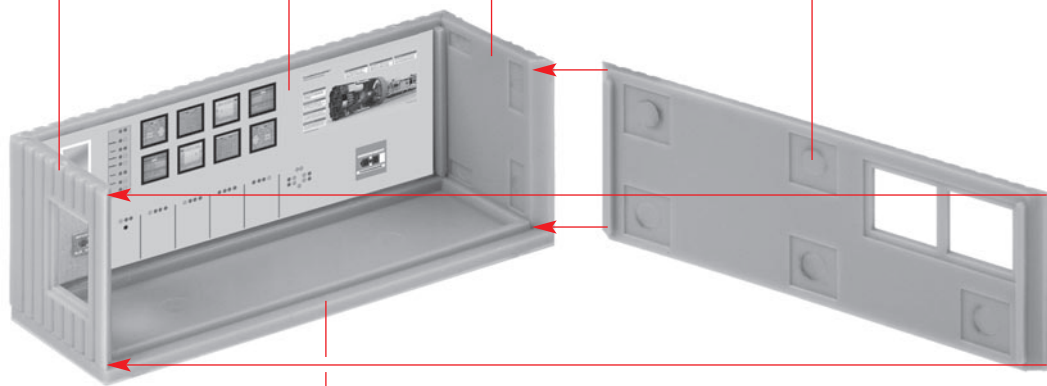

11/28

u

11/28

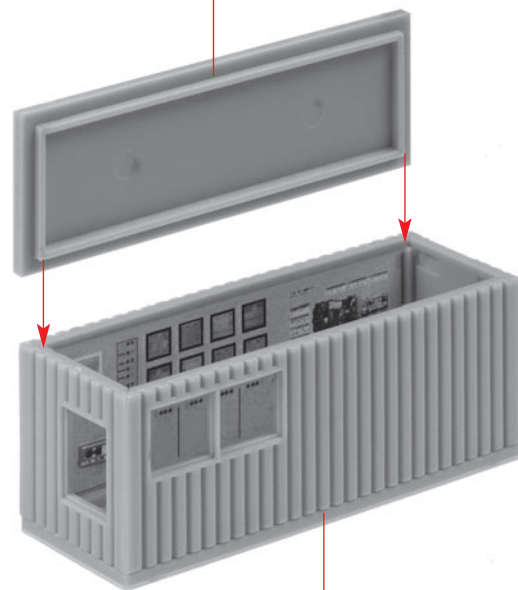

v

u

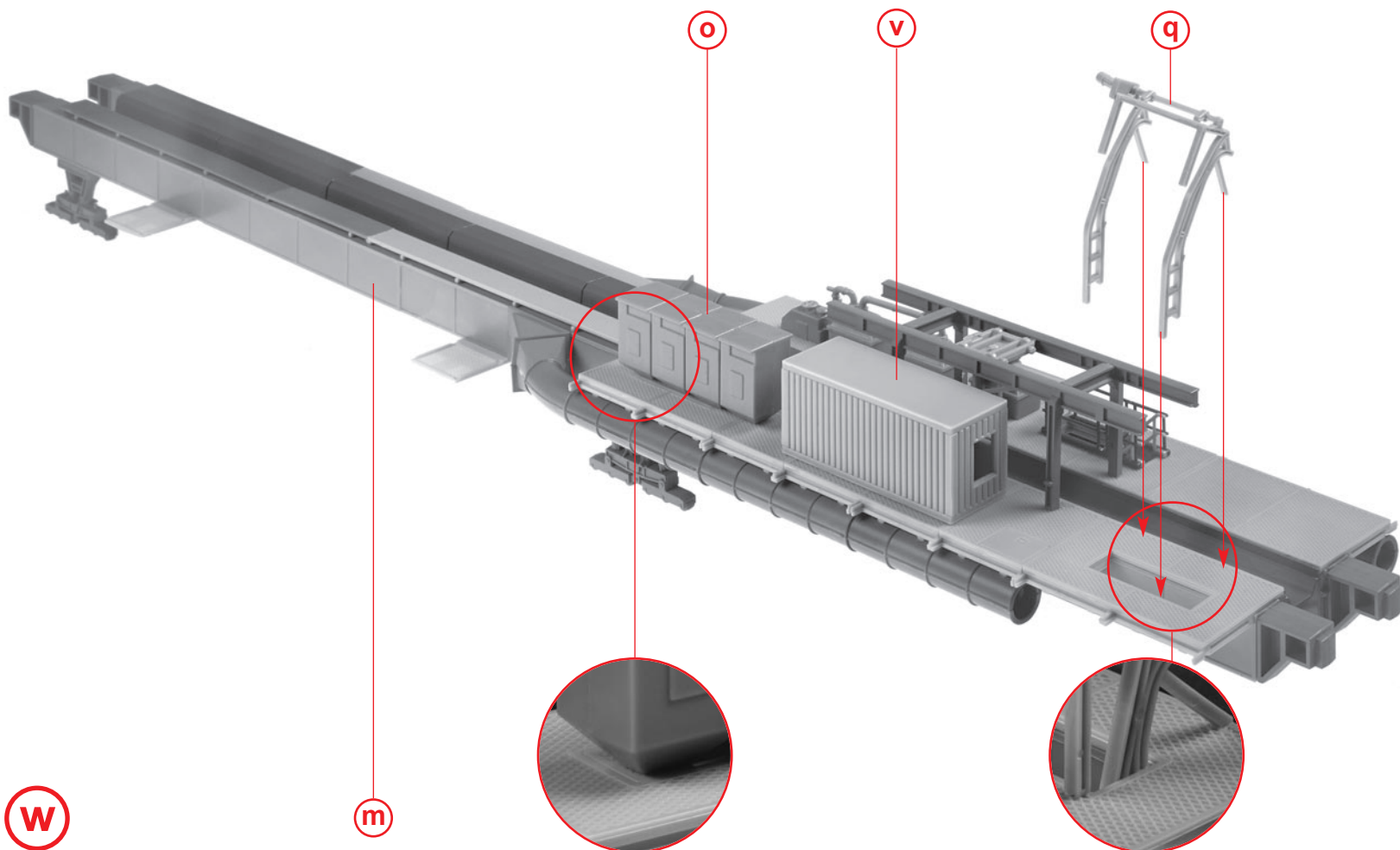

w

m

o

v

q

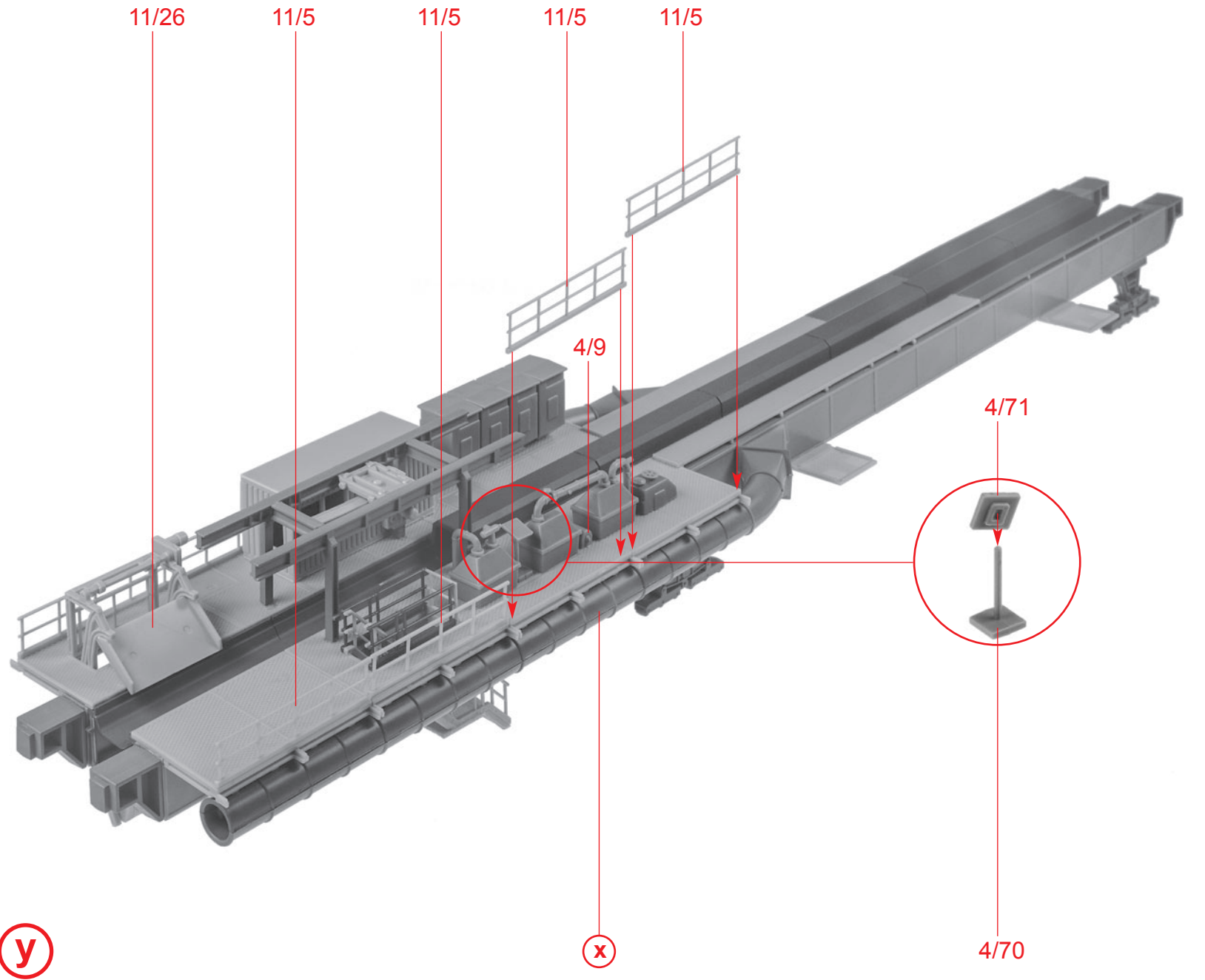
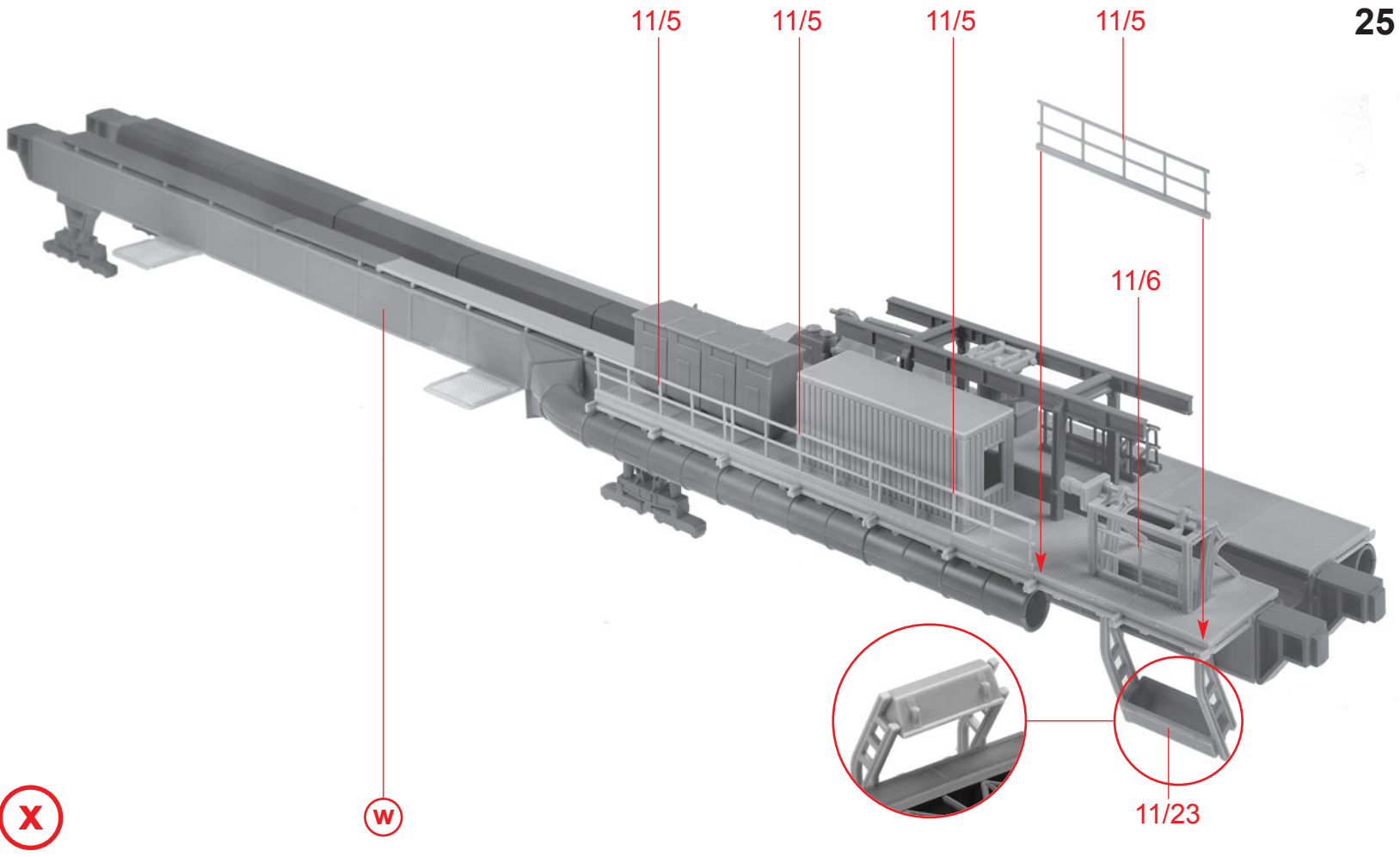

Z

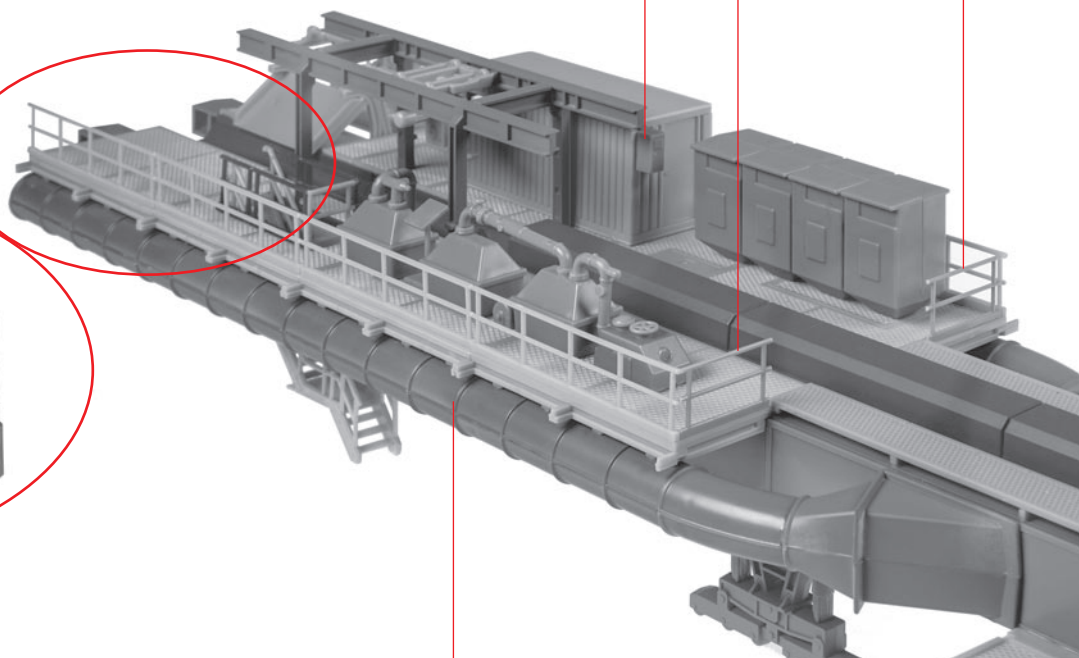
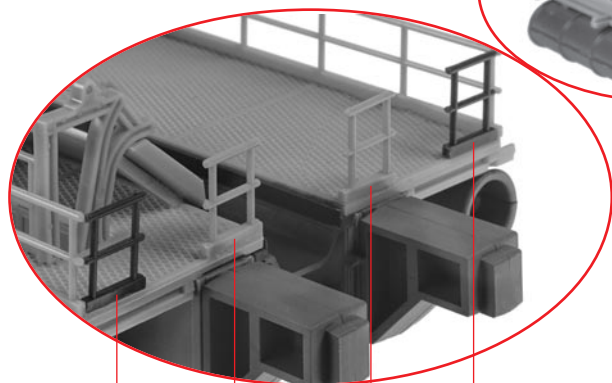
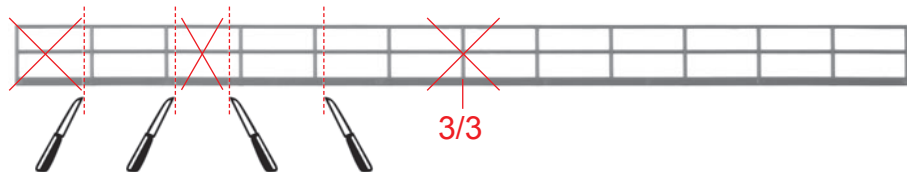

4/10 **Z**

Z

A

8/8

9/1

9/1

8/8

y

B

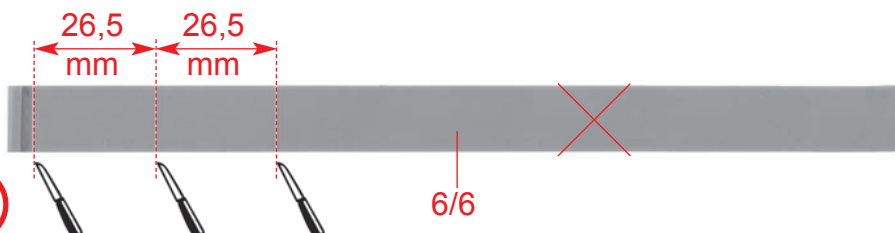

C 2 x

11/19

B

11/19

D 2 x

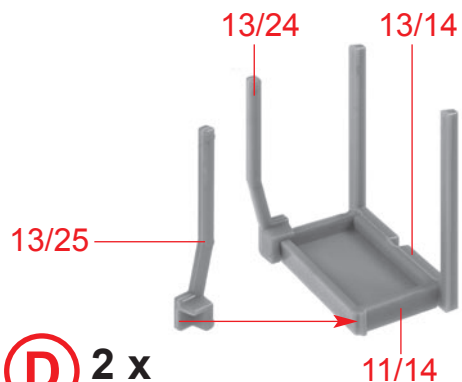

E 2 x

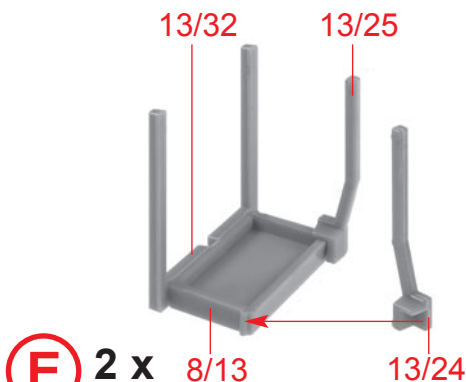

G 2 x

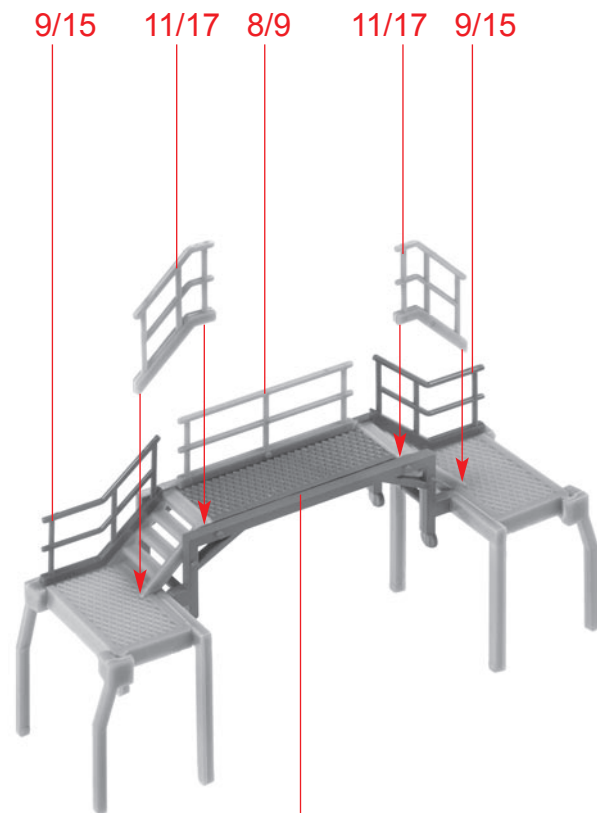

F

F 2 x

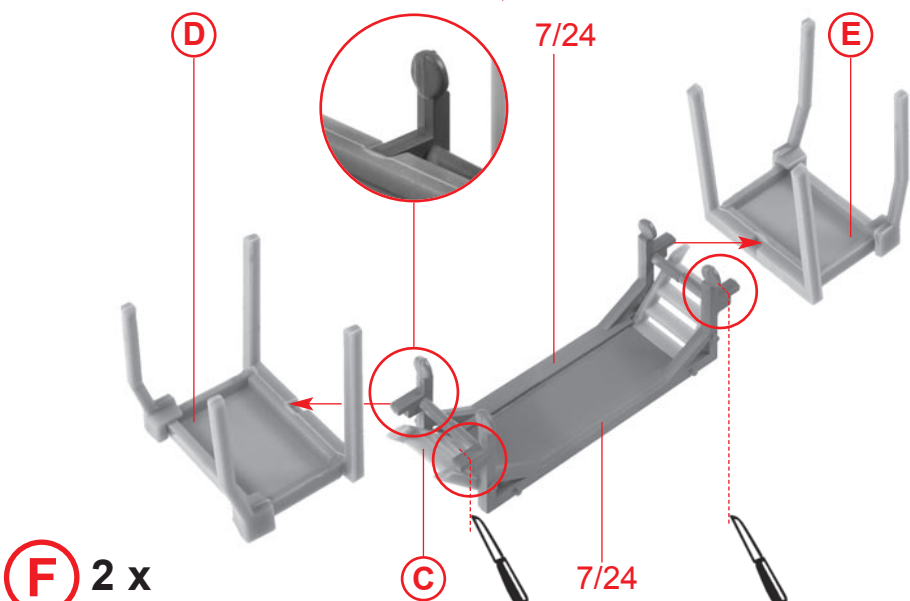

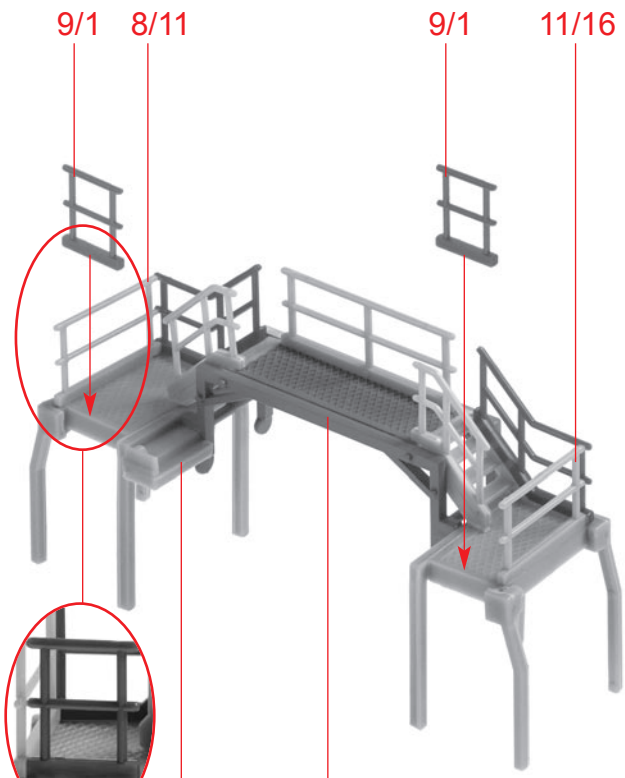

H 2 x

8/16

G

I 2 x

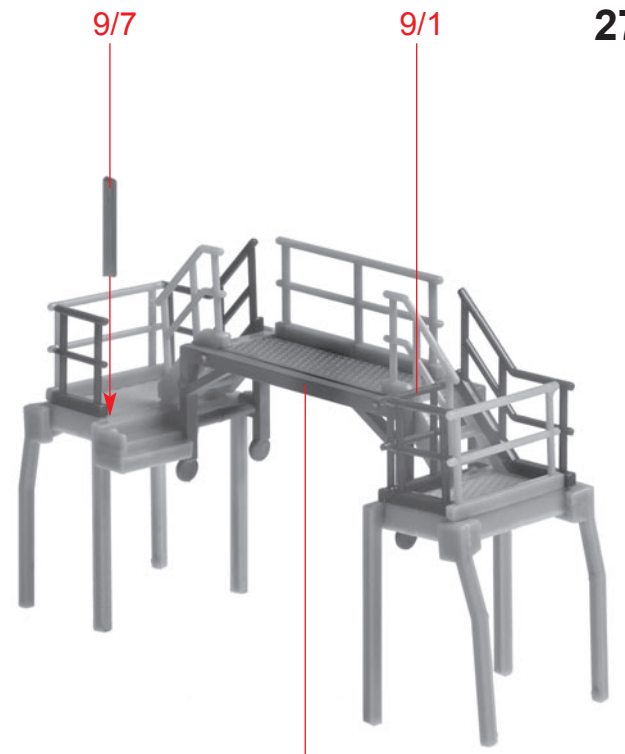

H

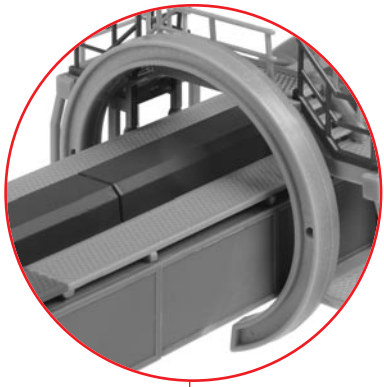
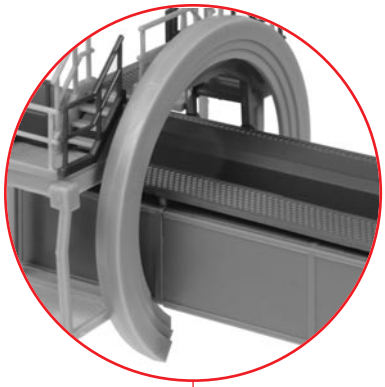

I

I

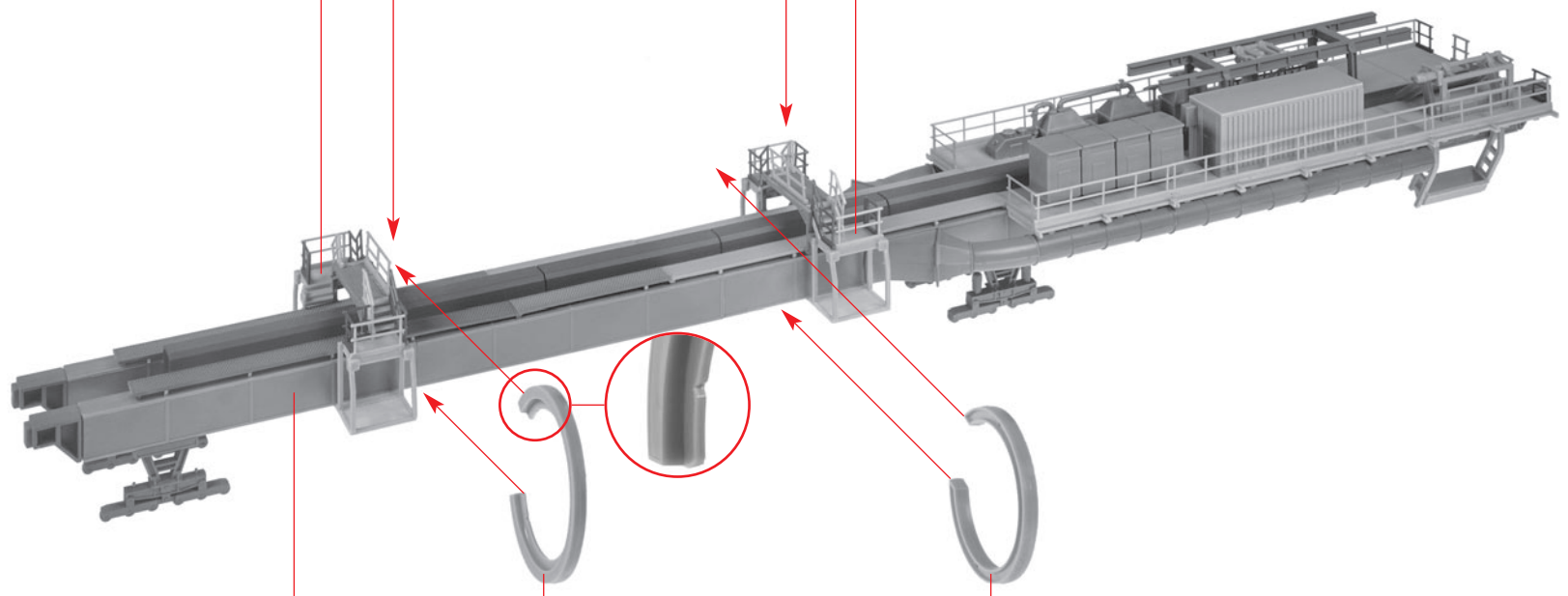

J

A

7/2

2/11

28

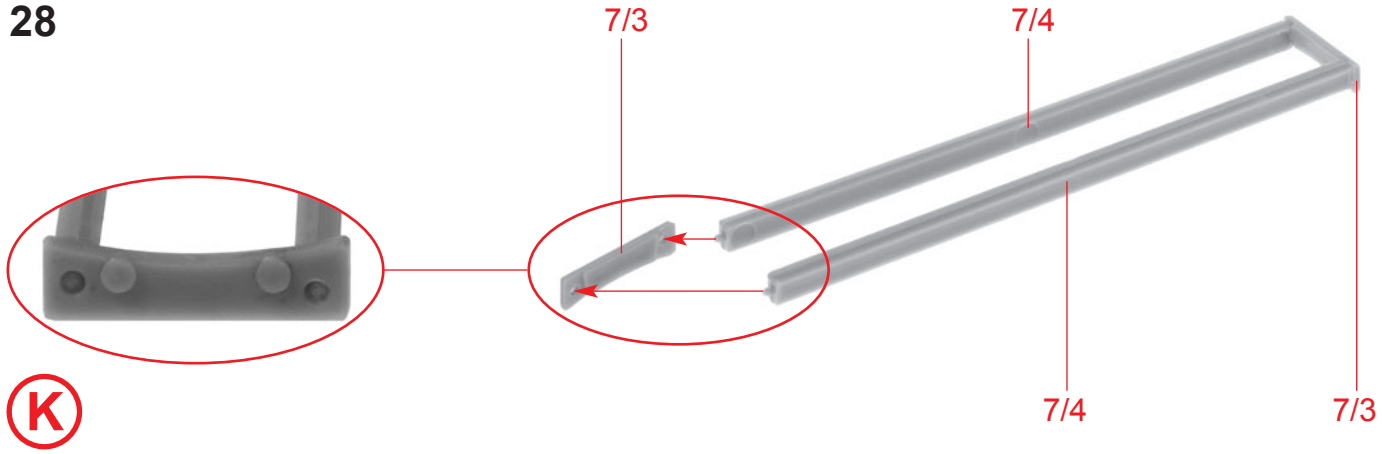

(K)

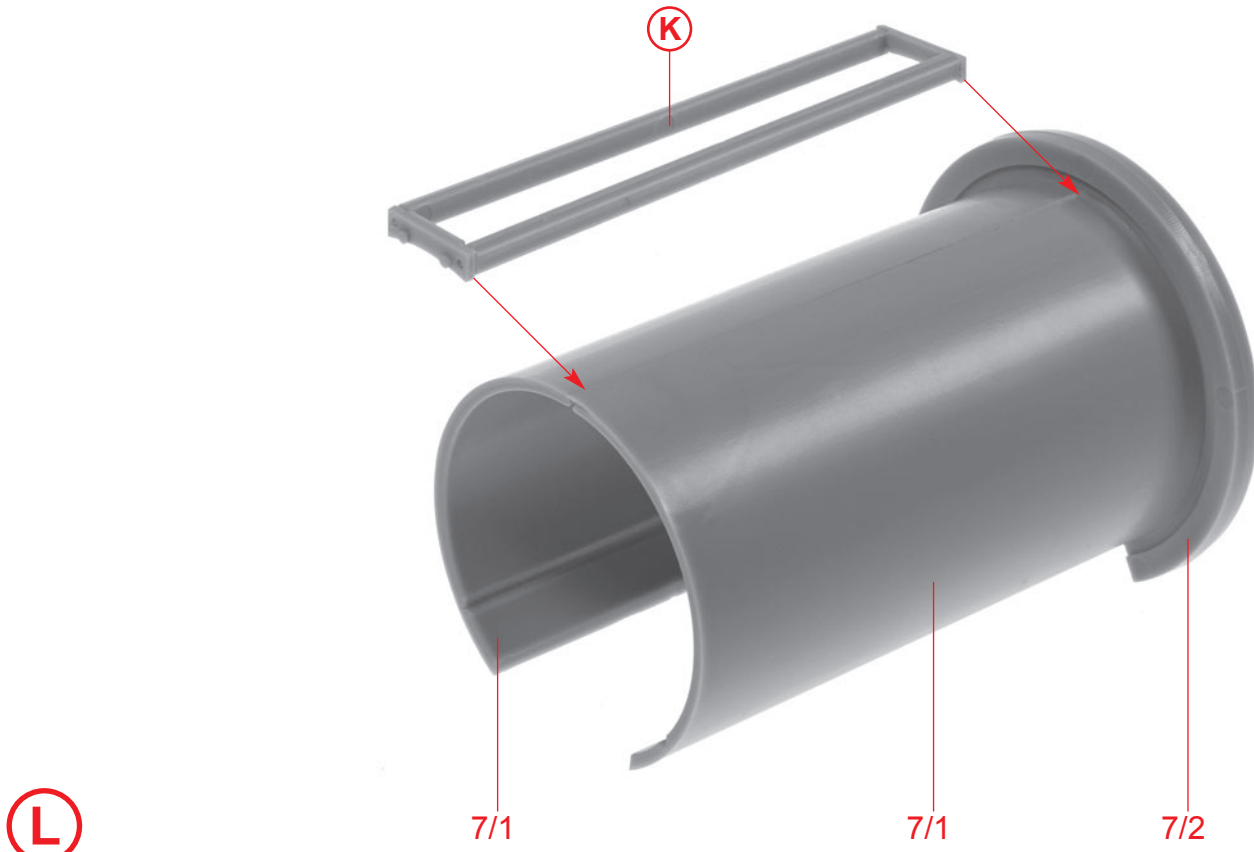

(L)

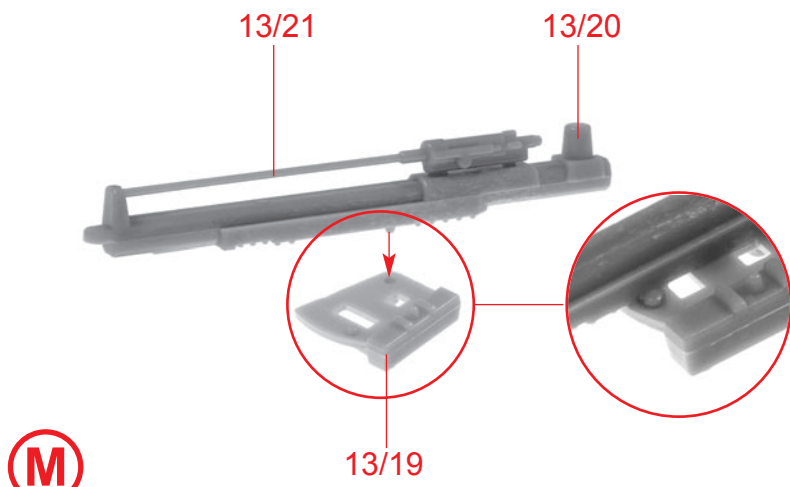

(M)

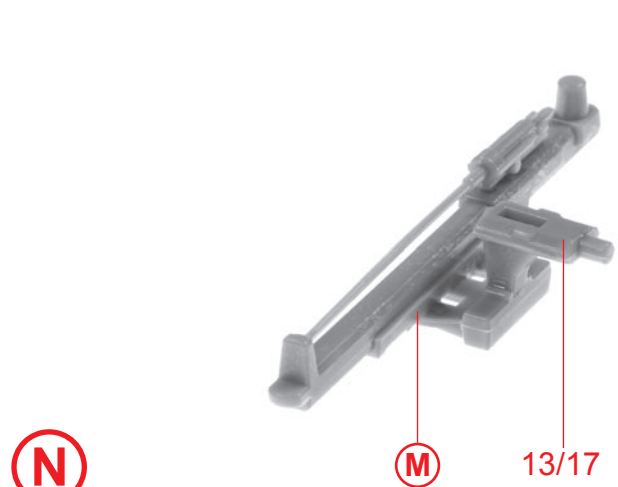

(N)

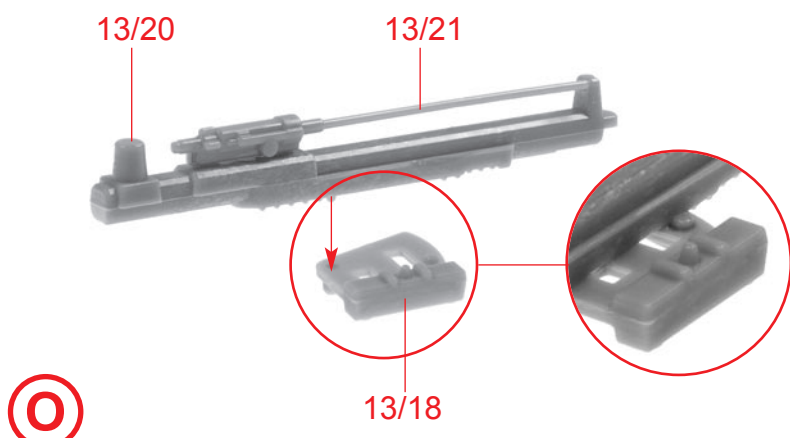

(O)

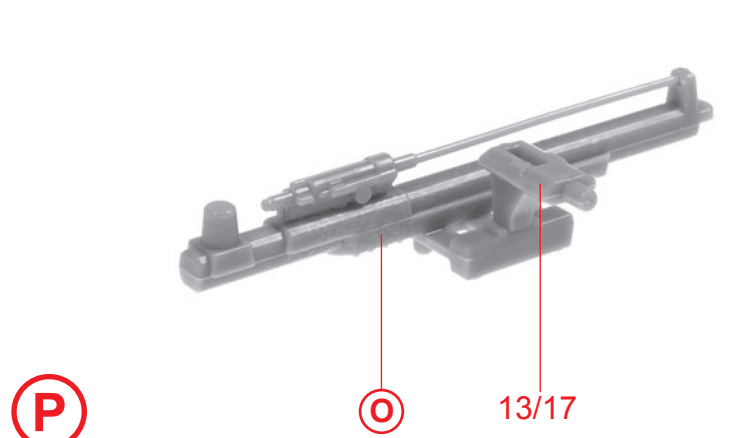

(P)

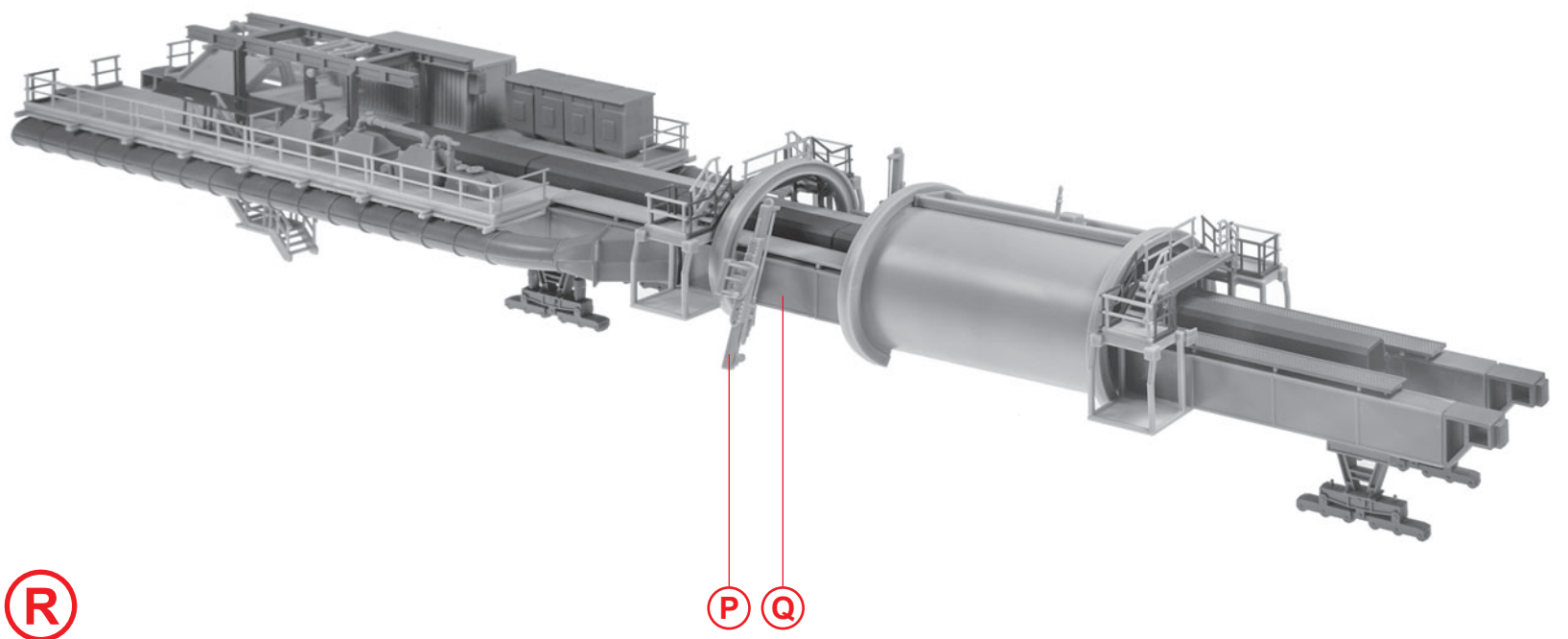
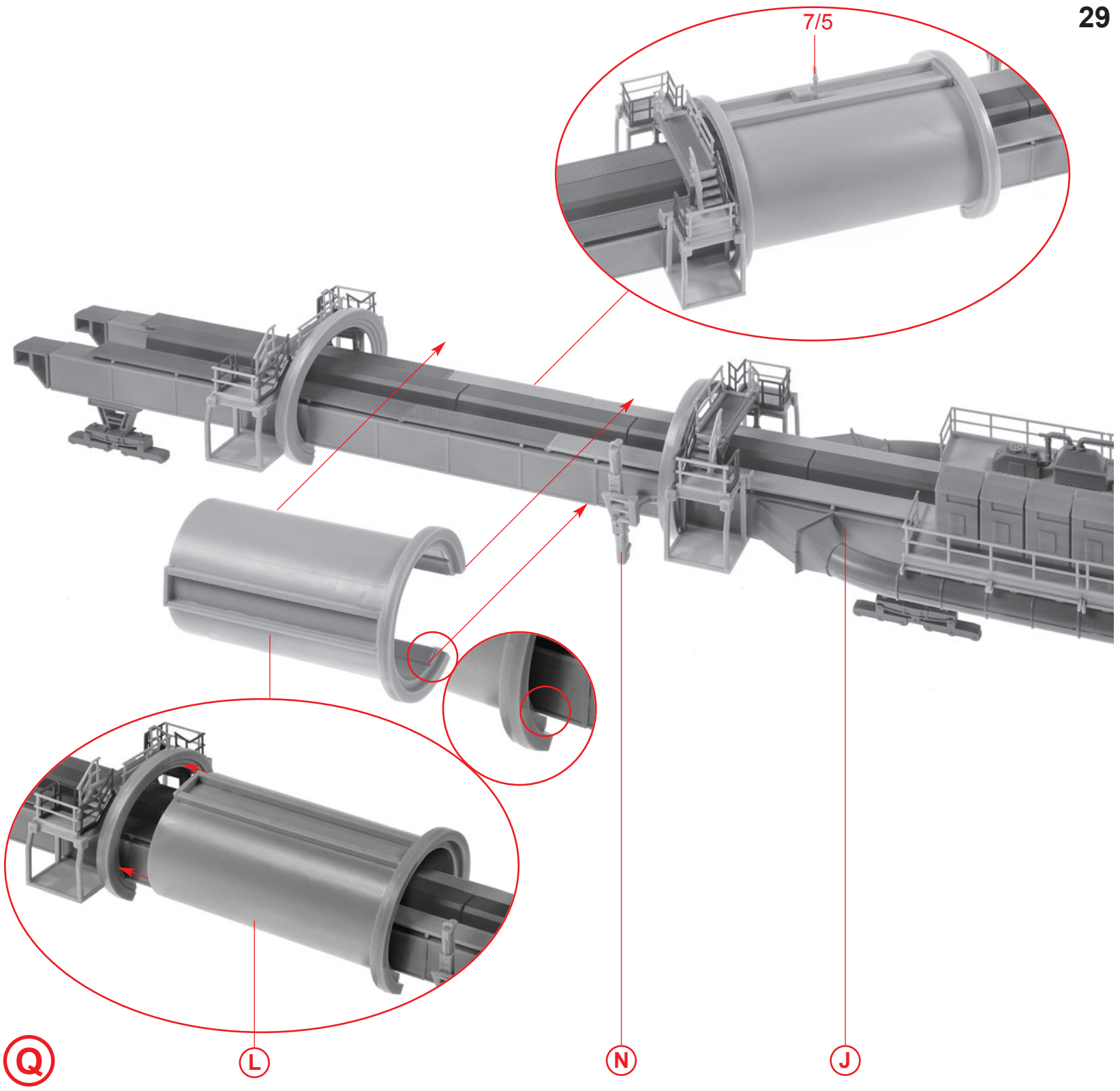

30

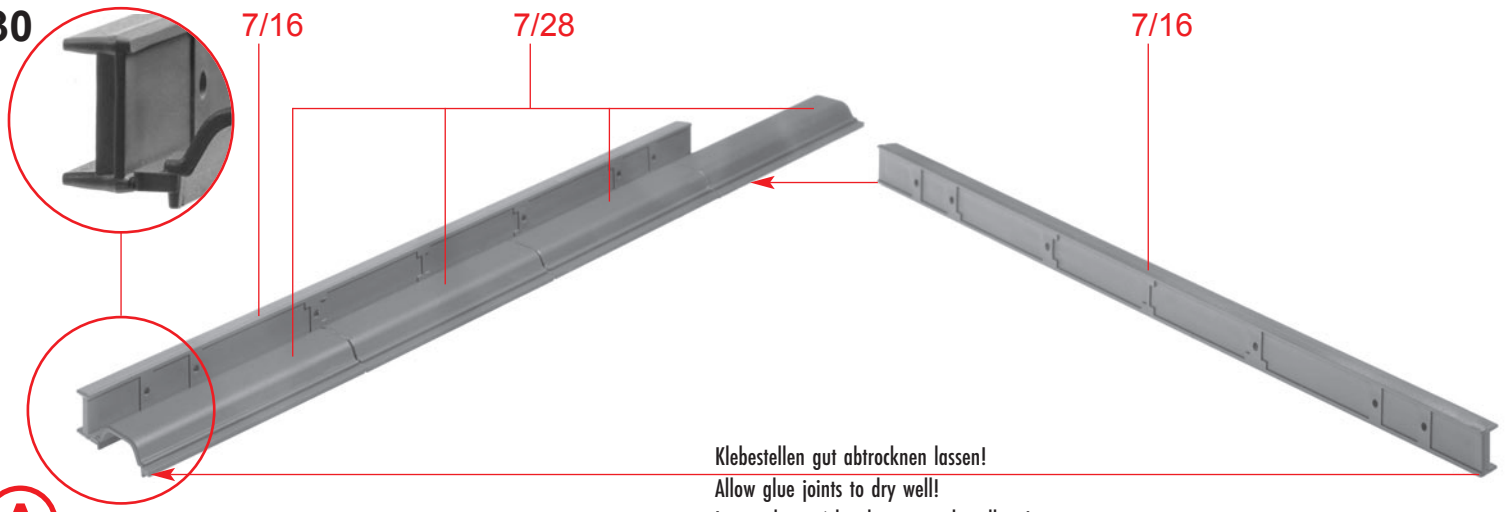

A

Klebestellen gut abtrocknen lassen!
 Allow glue joints to dry well!
 Laisser bien sécher les points de collage!
 Alle gelijmde punten goed laten drogen!

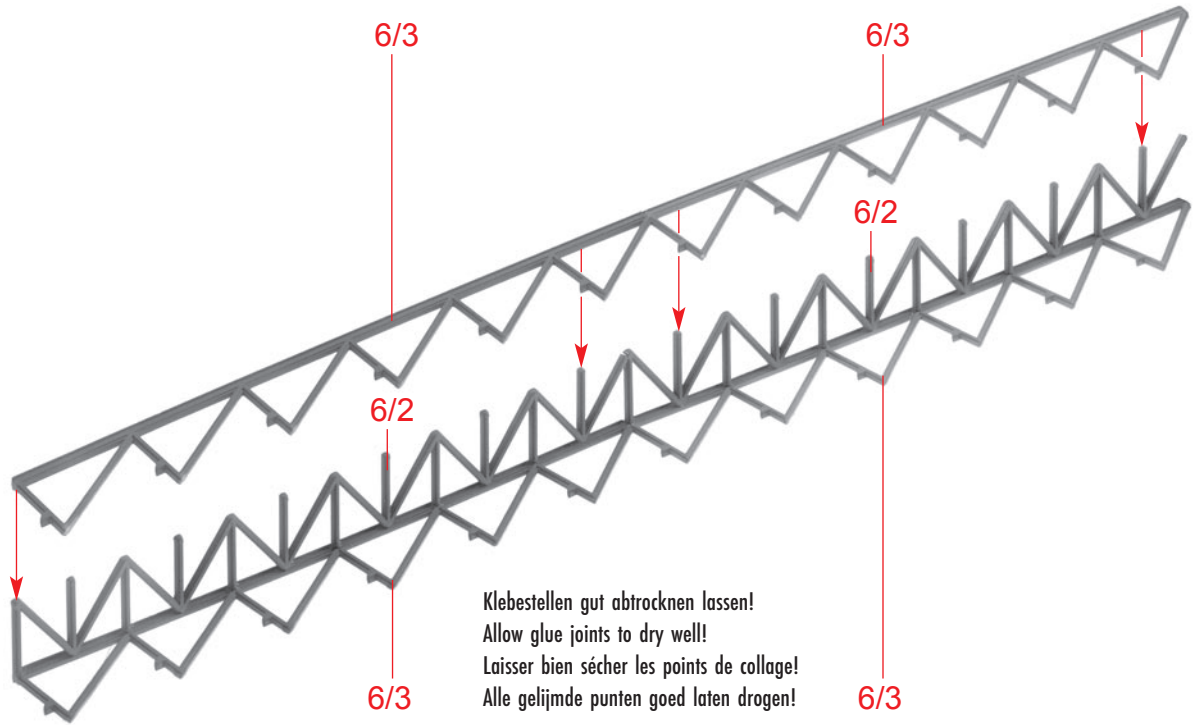

B

Klebestellen gut abtrocknen lassen!
 Allow glue joints to dry well!
 Laisser bien sécher les points de collage!
 Alle gelijmde punten goed laten drogen!

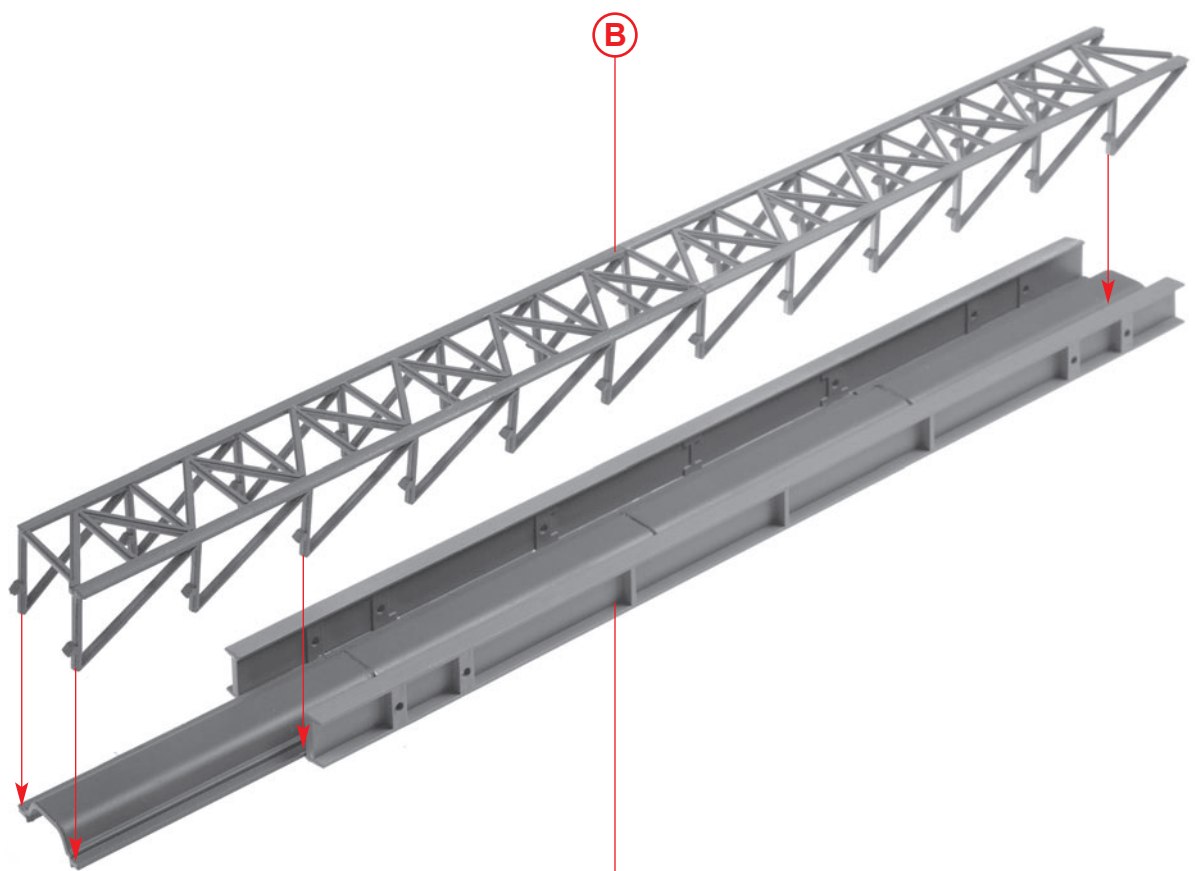

C

A

D

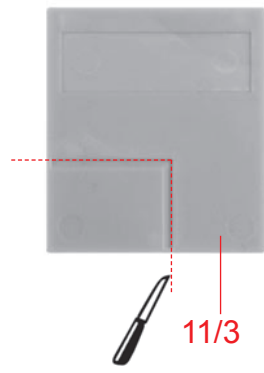

E

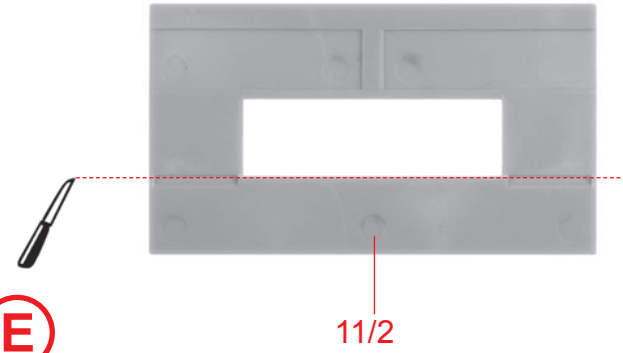

F

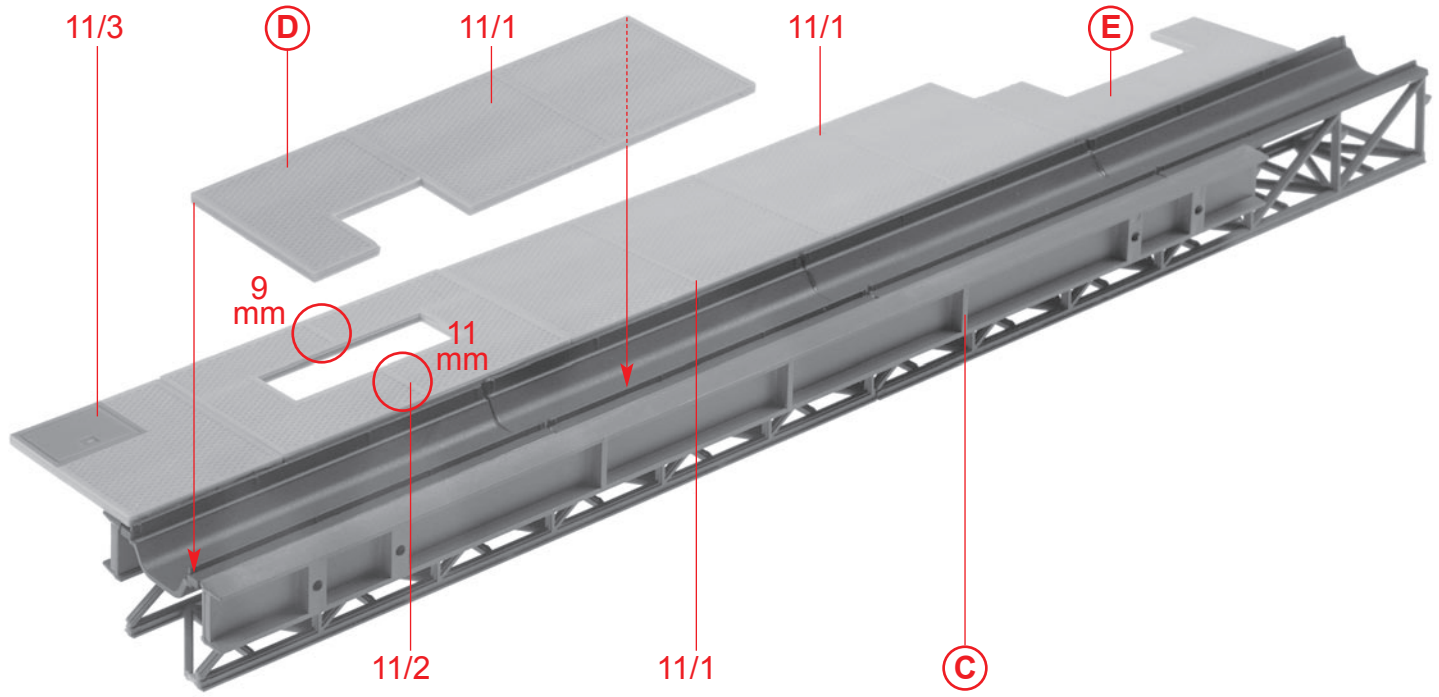

G

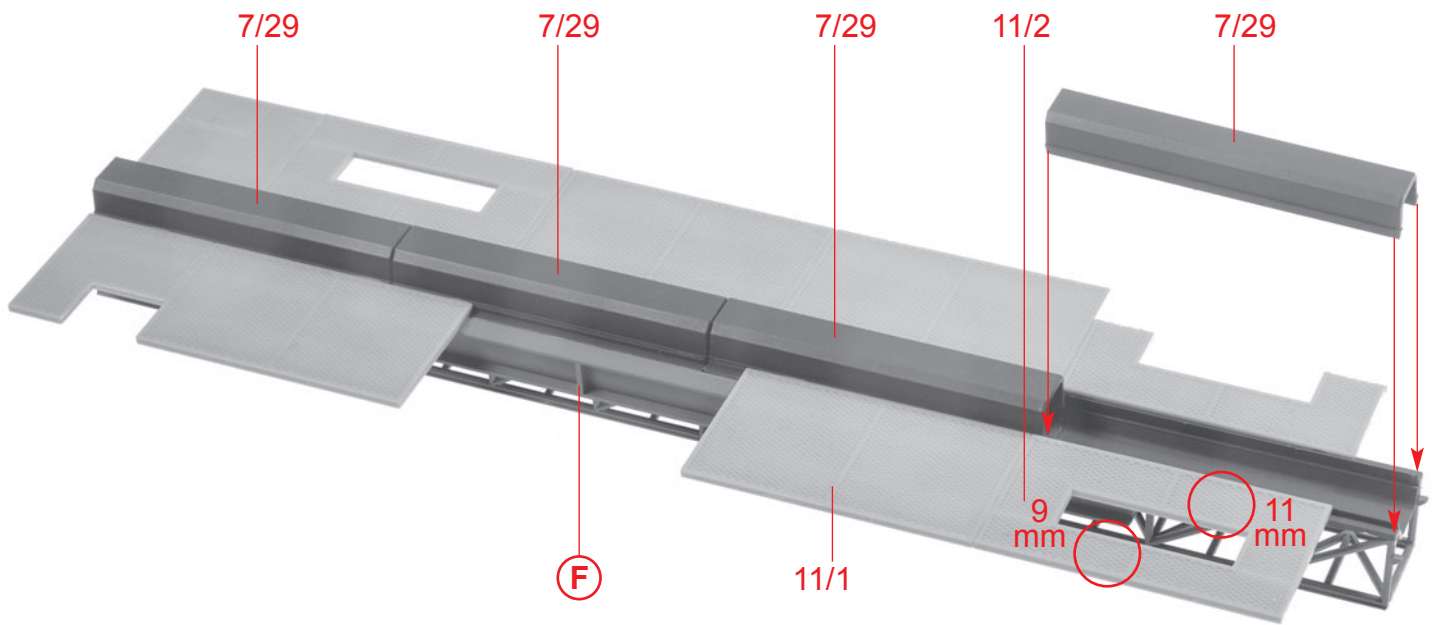

H

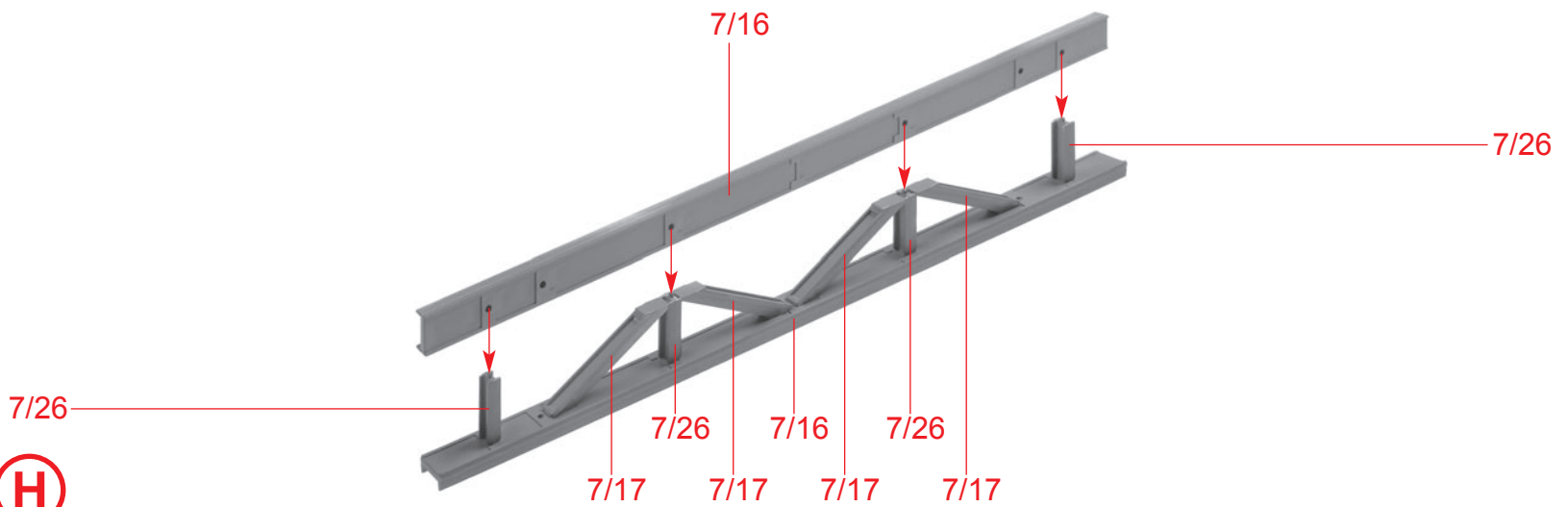

32

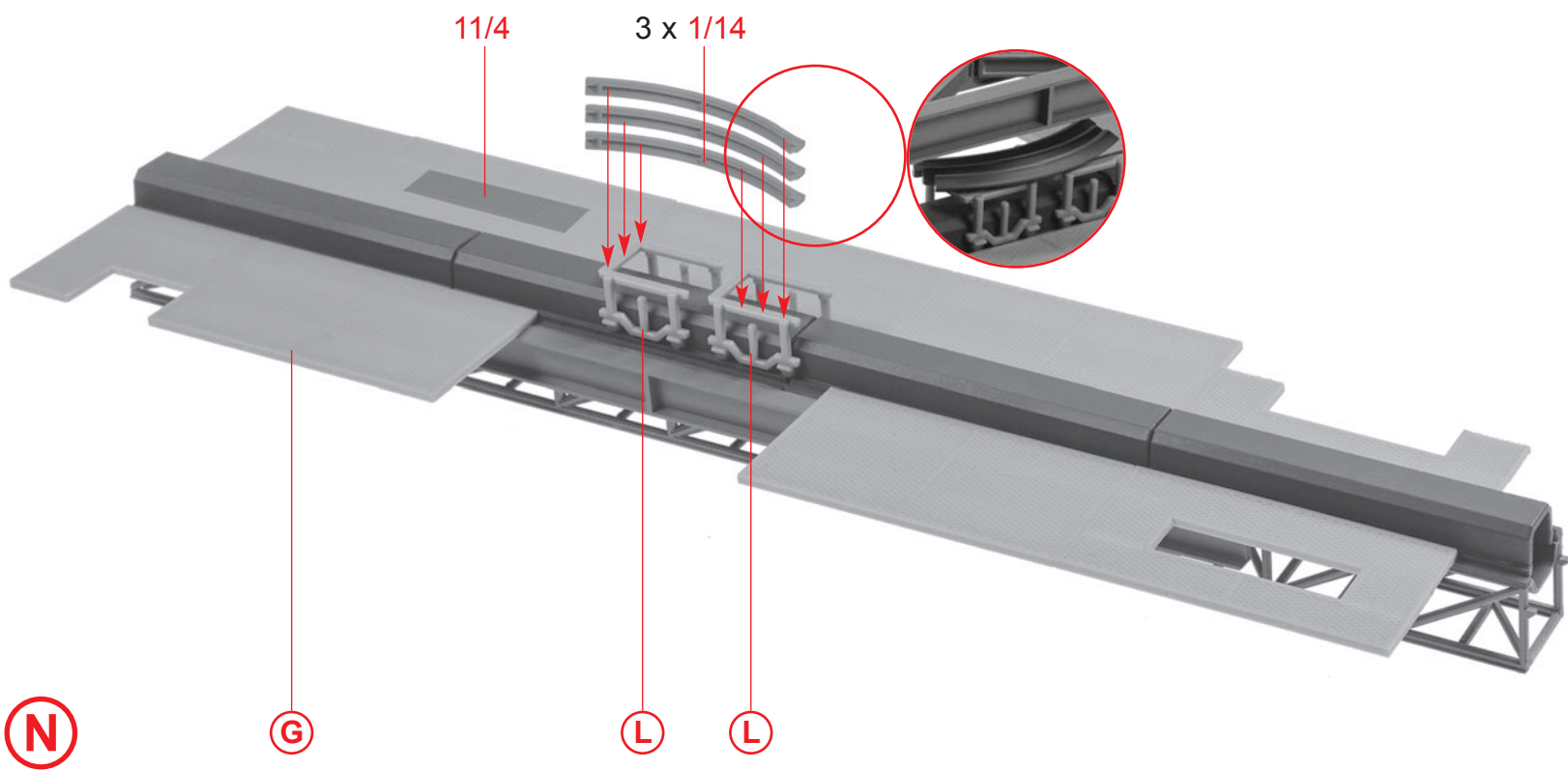
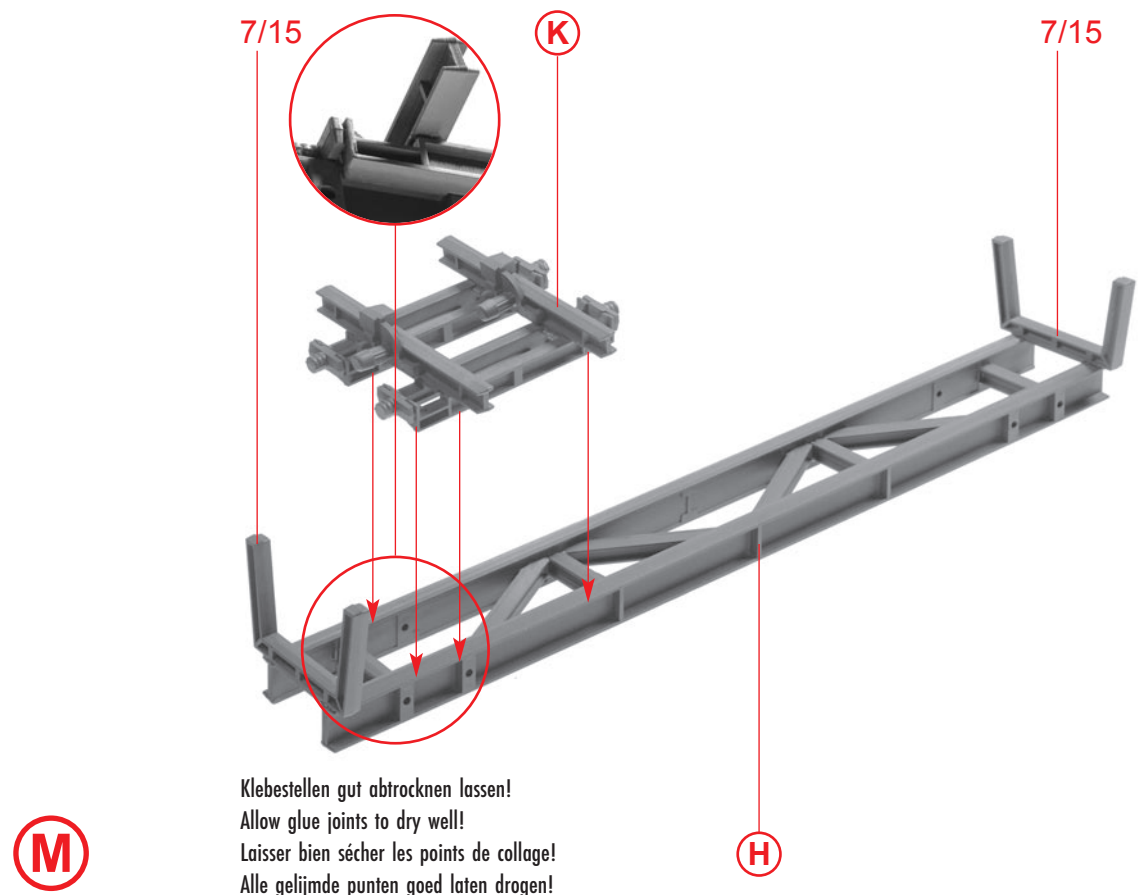
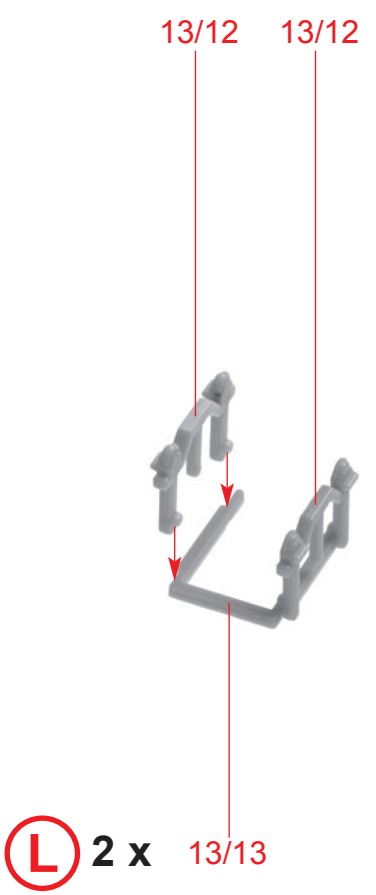
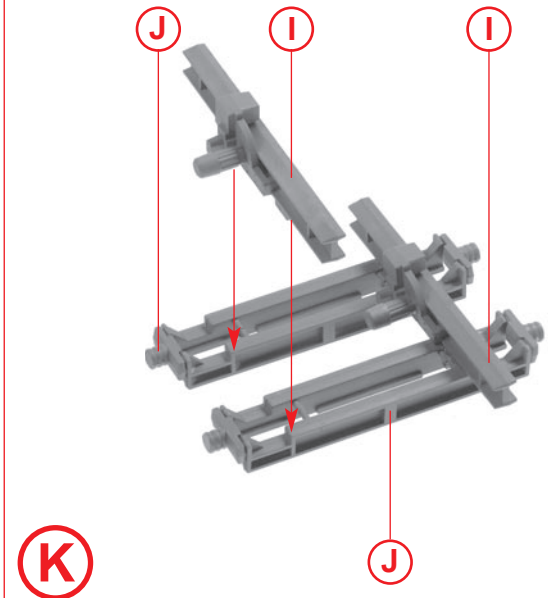
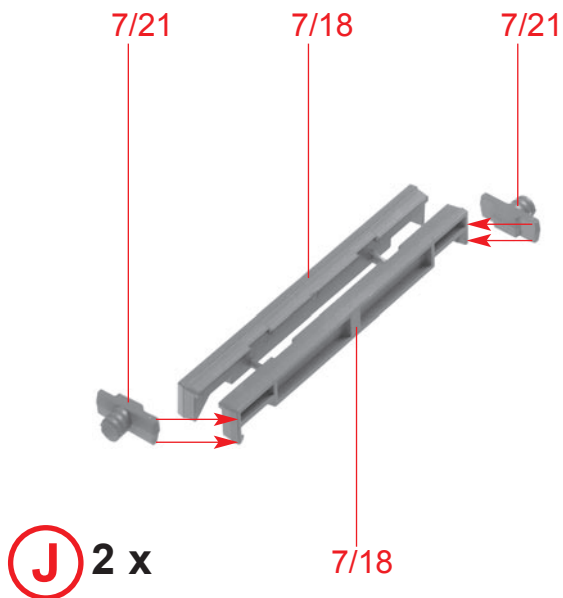
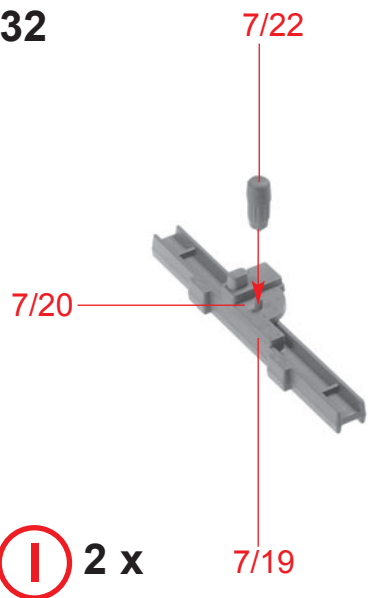

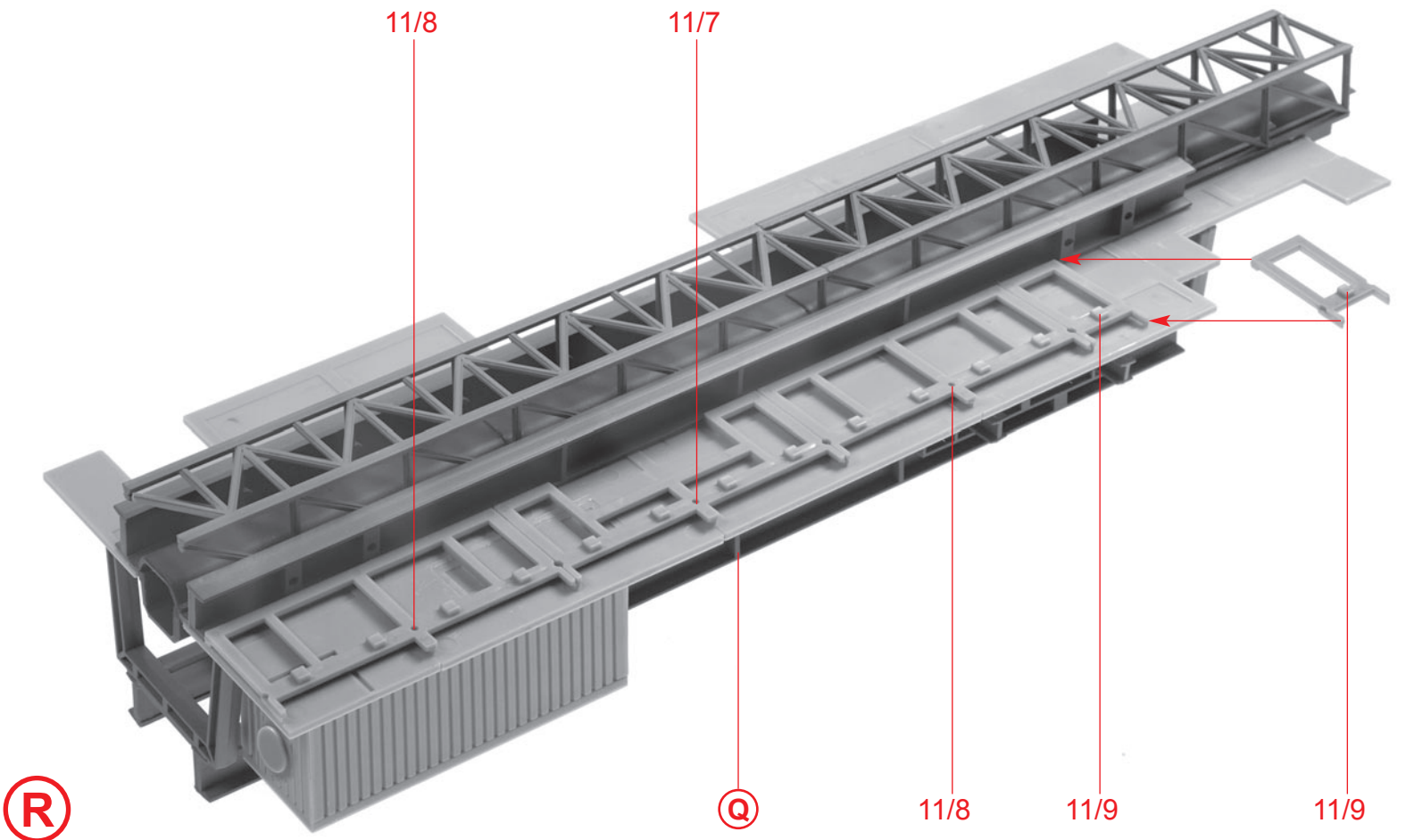
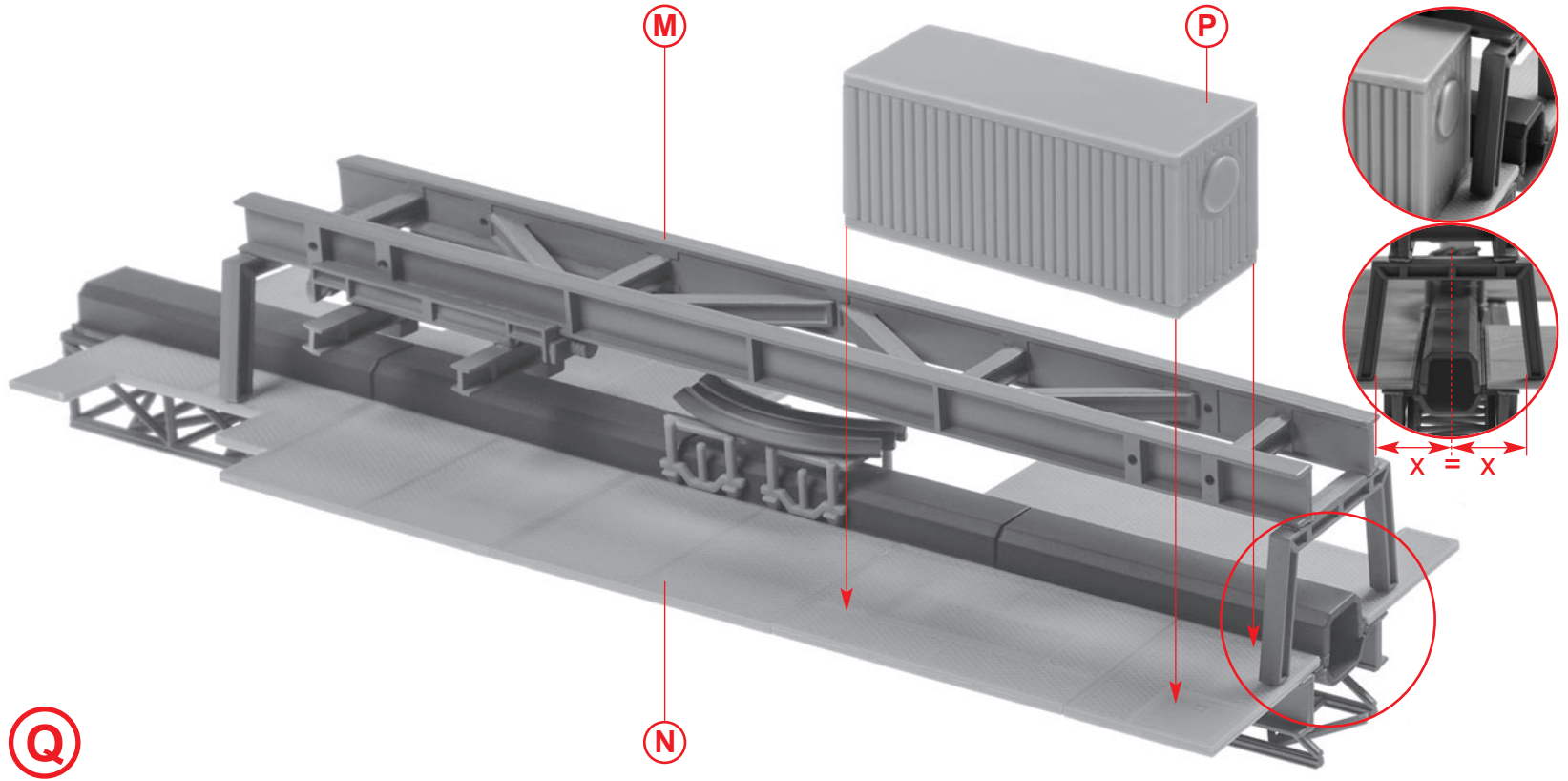
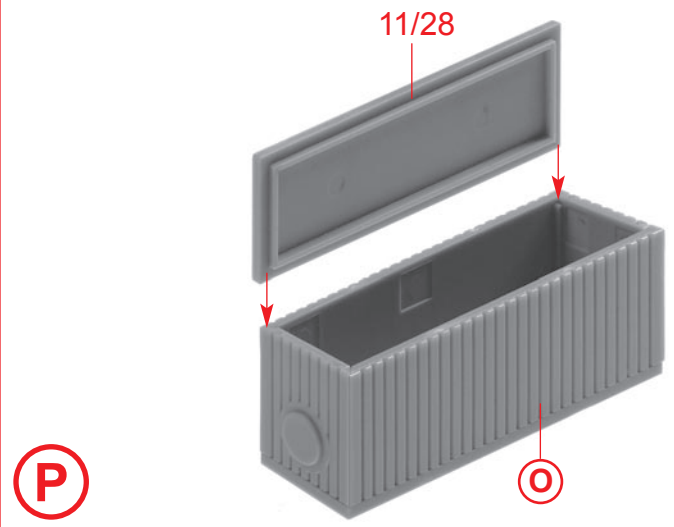
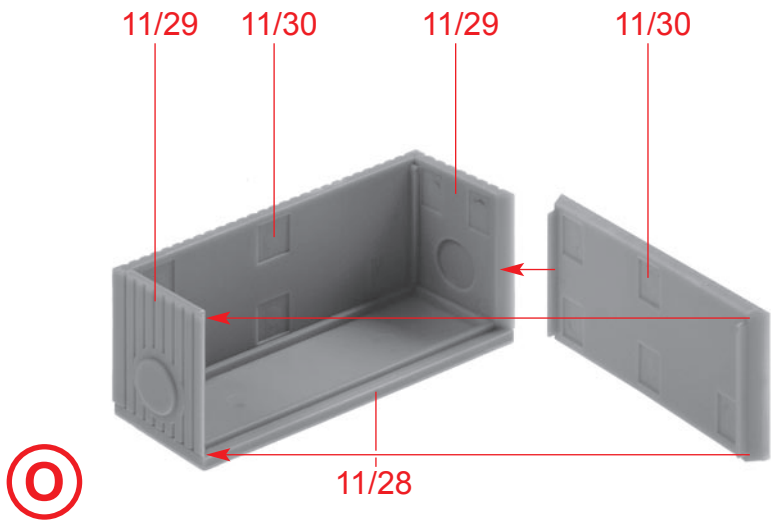

34

7/9

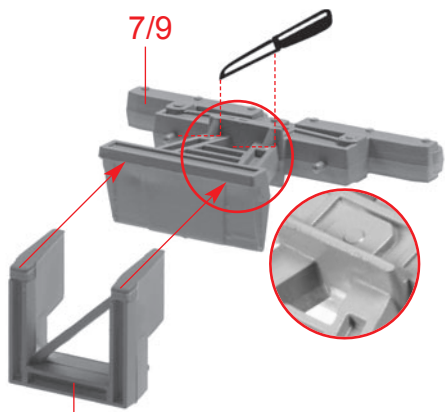

S 4 x 7/8

50/12

50/14

50/13

T

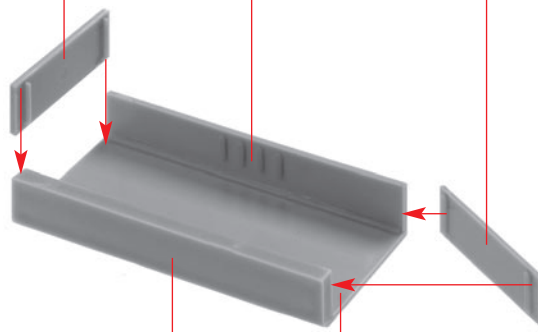

50/9

50/11

Deco 3

U

T

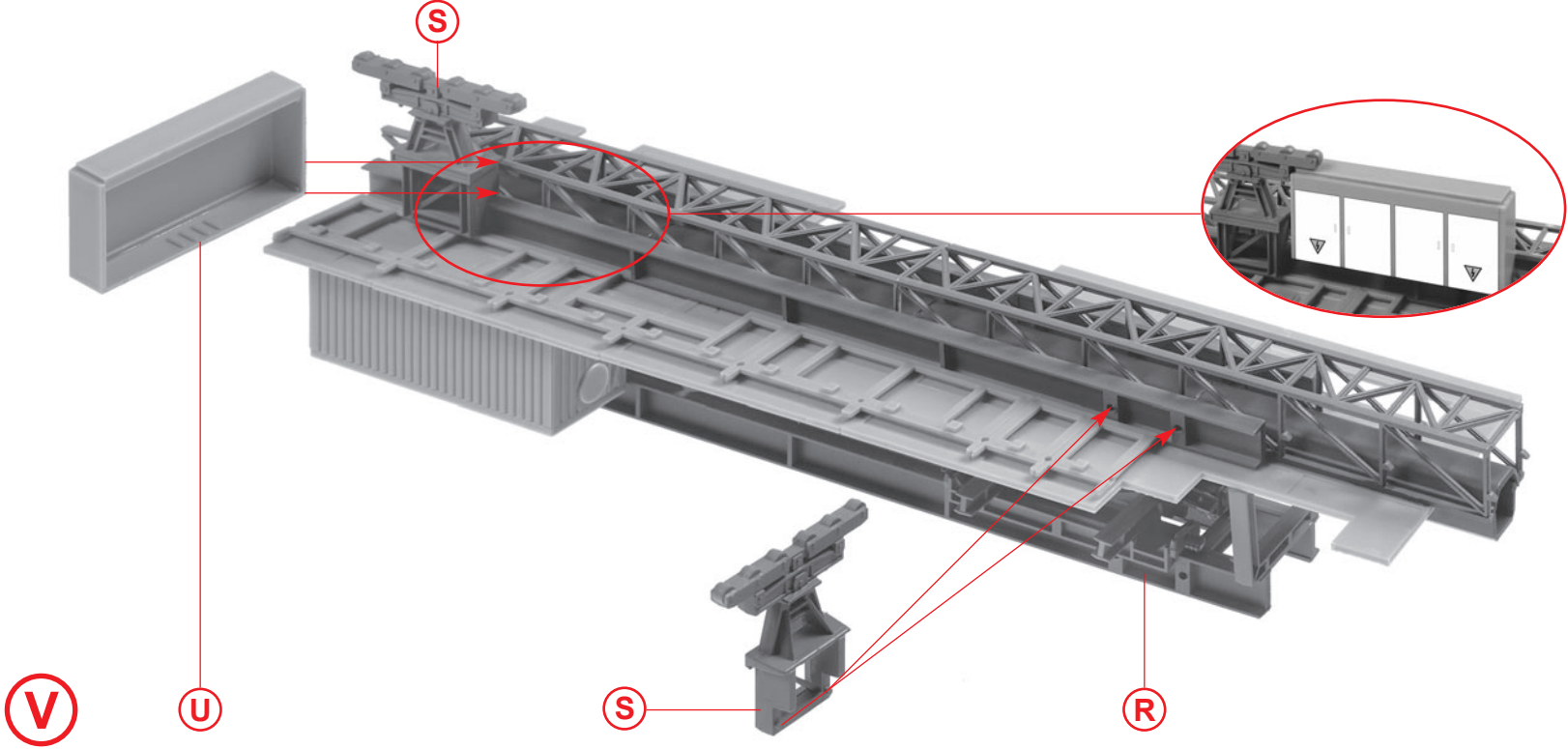
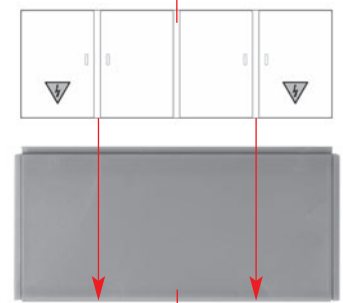

V

U

S

R

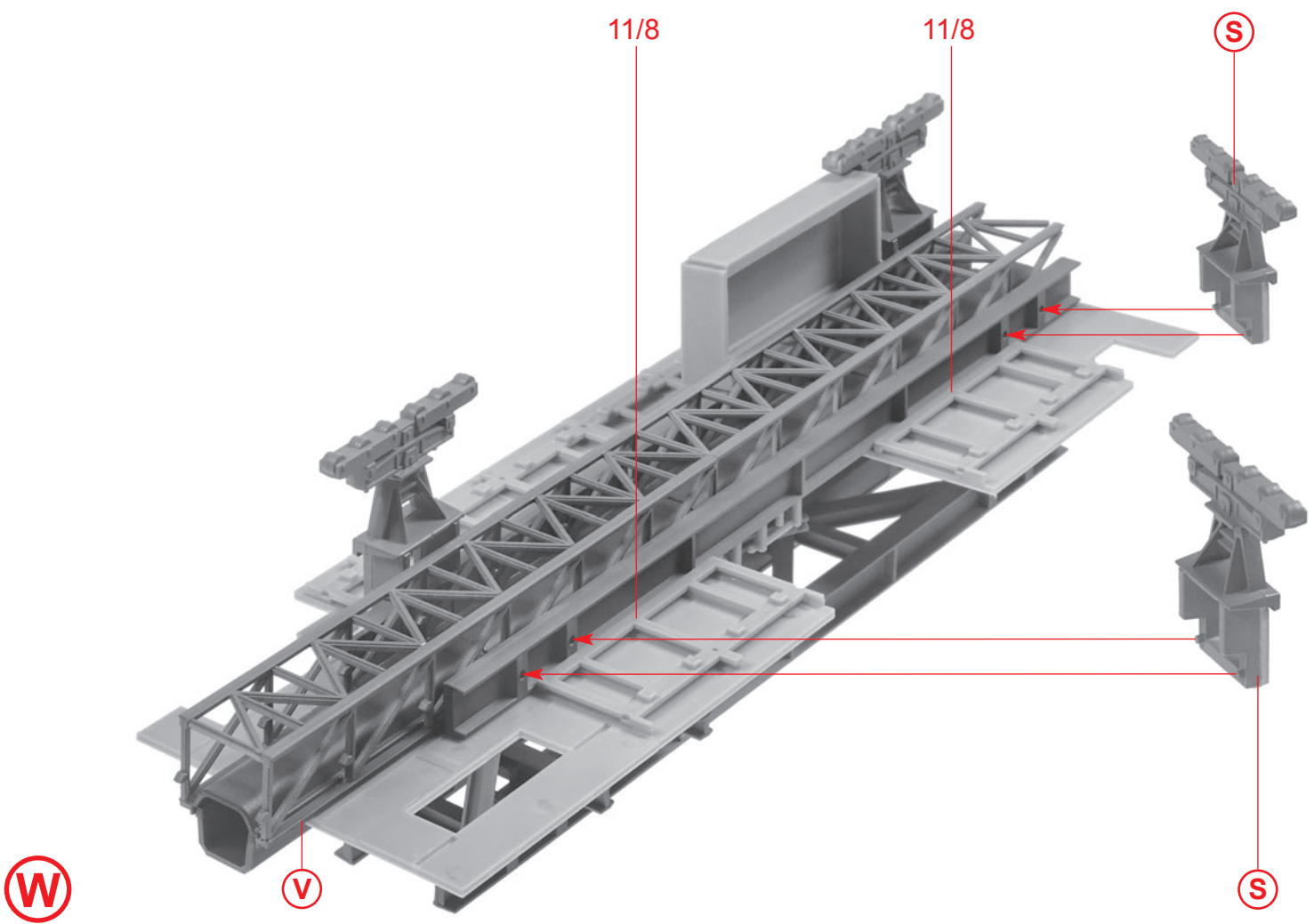

W

V

11/8

11/8

S

S

a

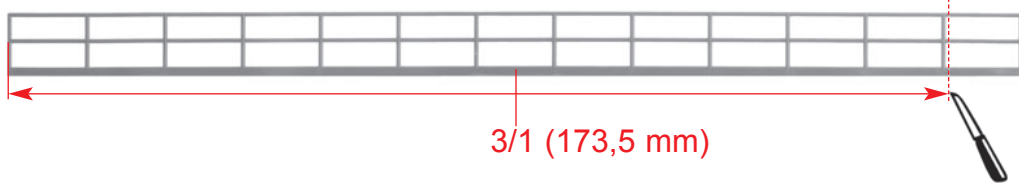

b

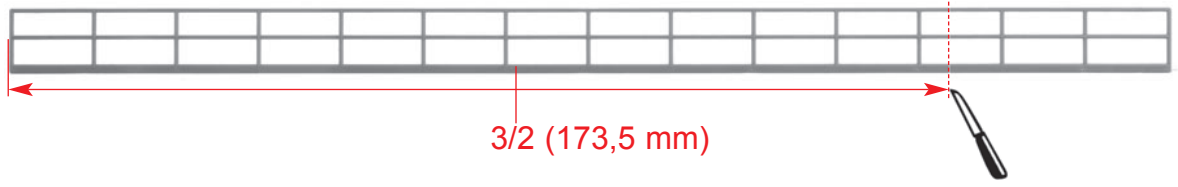

c 2 x

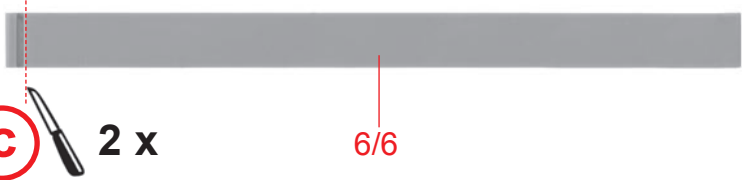

d 2 x

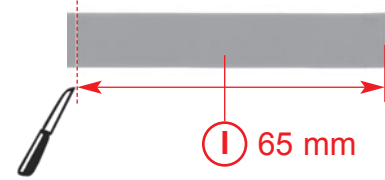

e 2 x



f

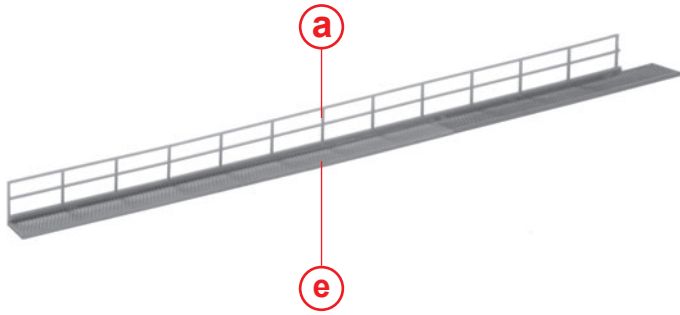

g

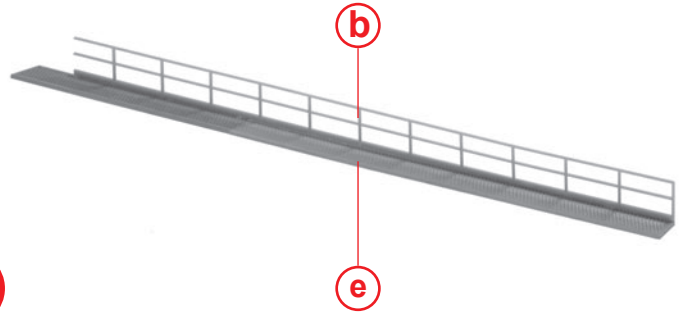

h

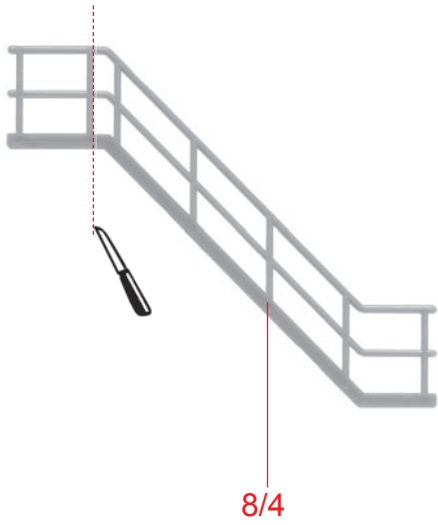

i

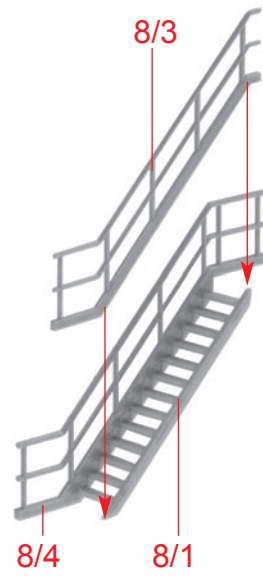

j

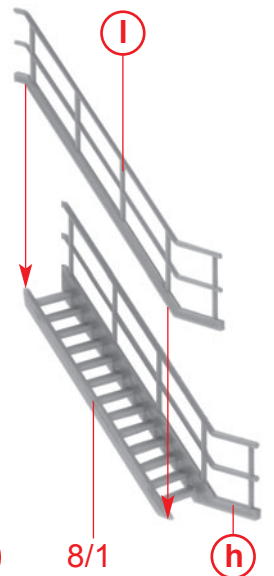

k

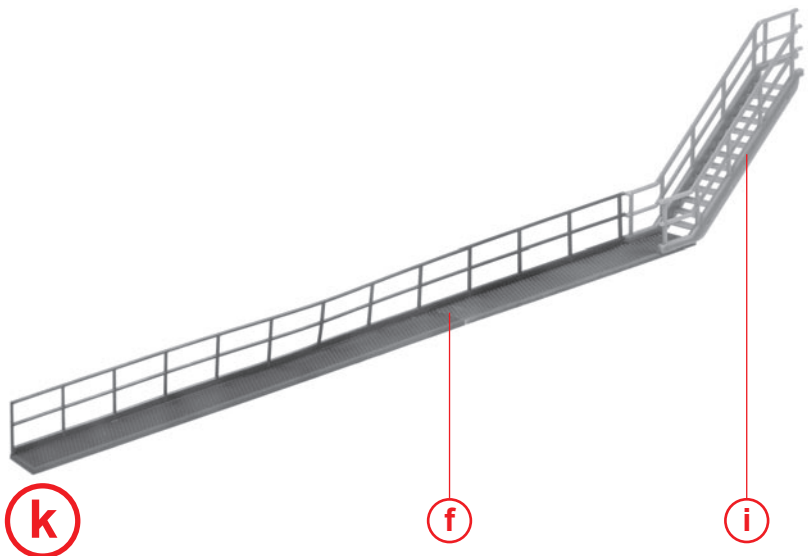

l

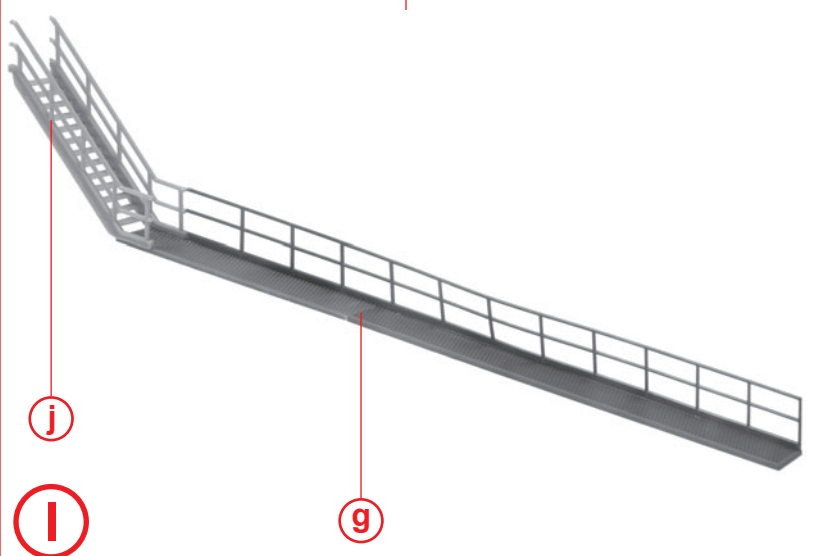

36

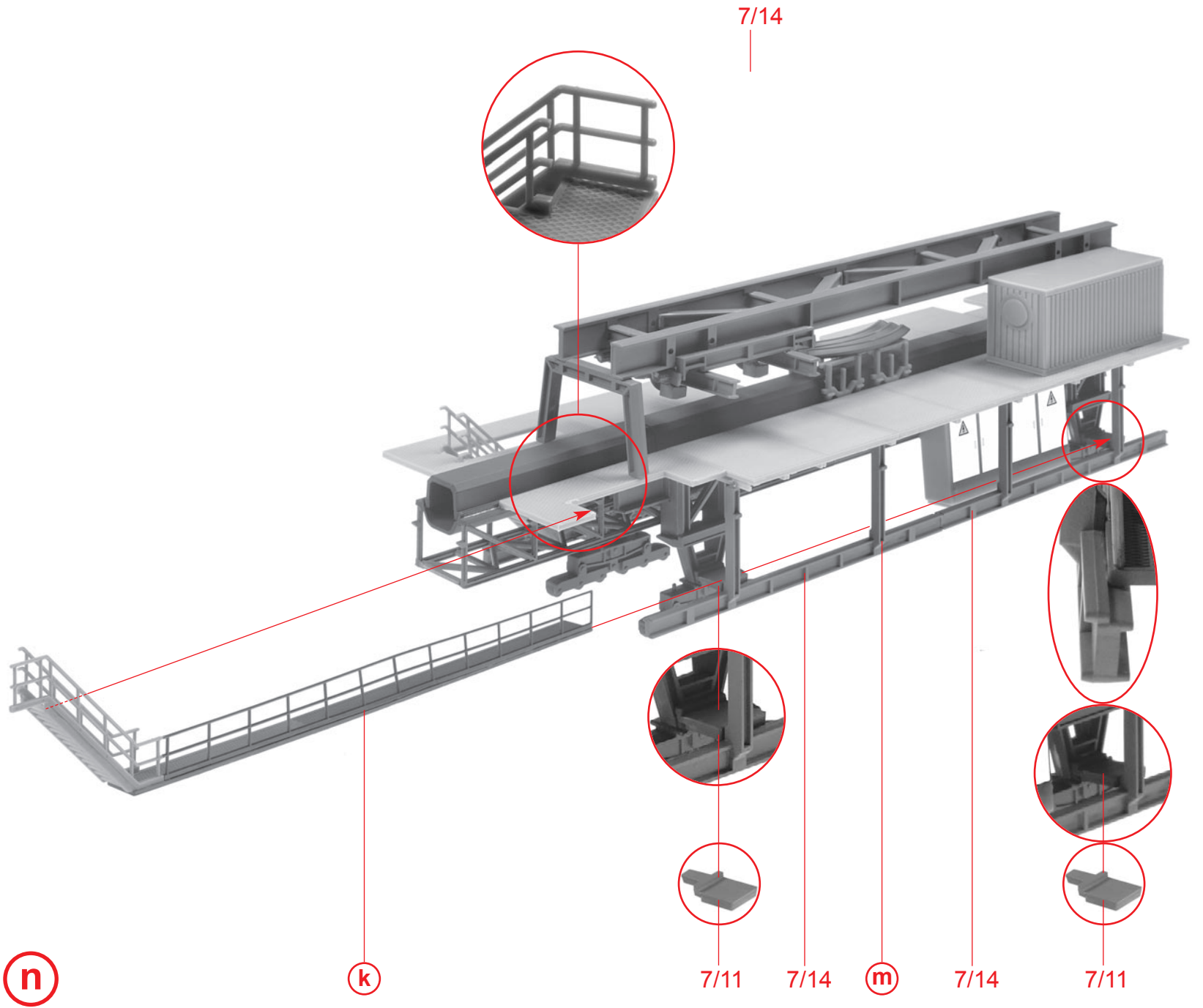
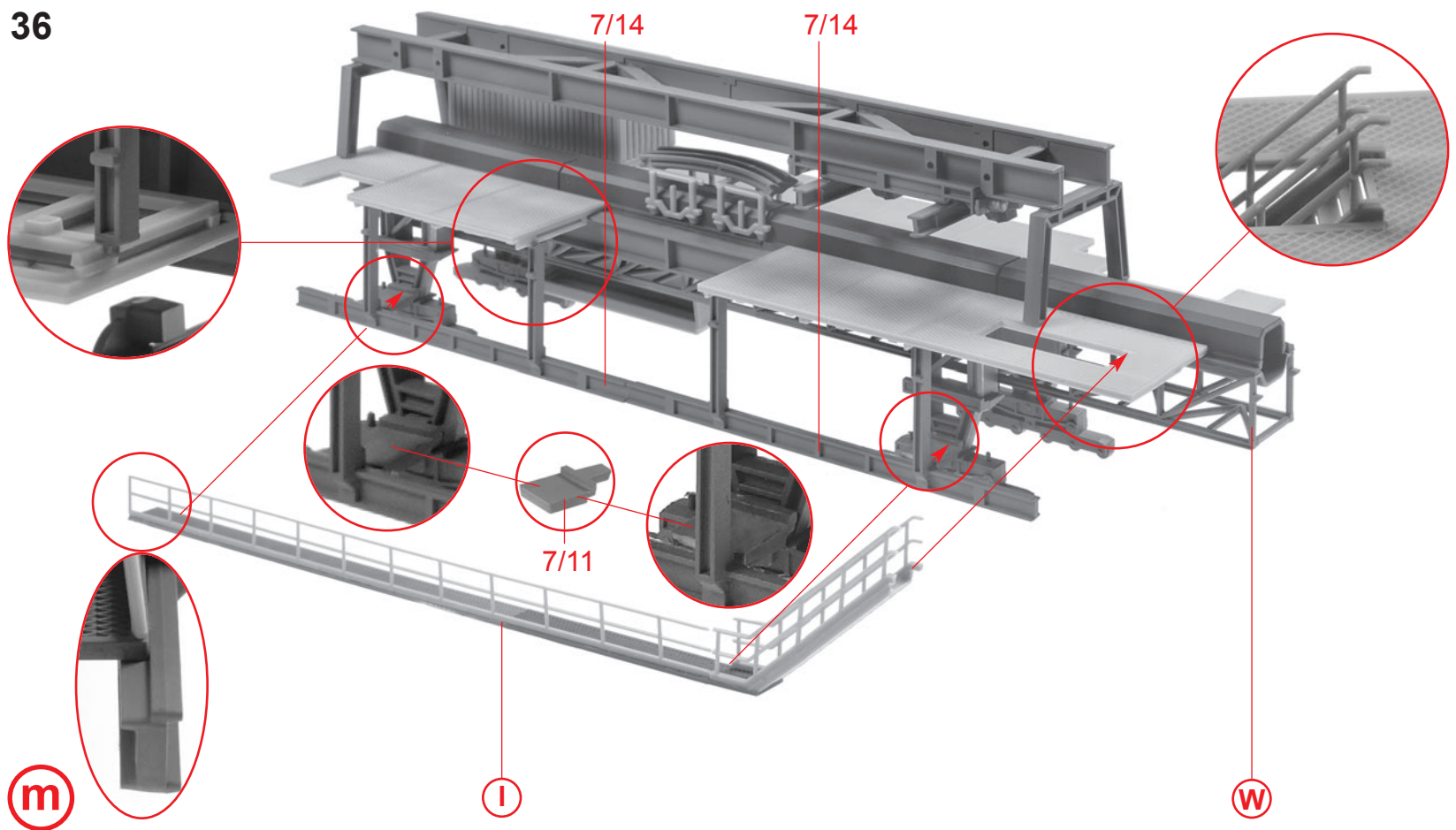

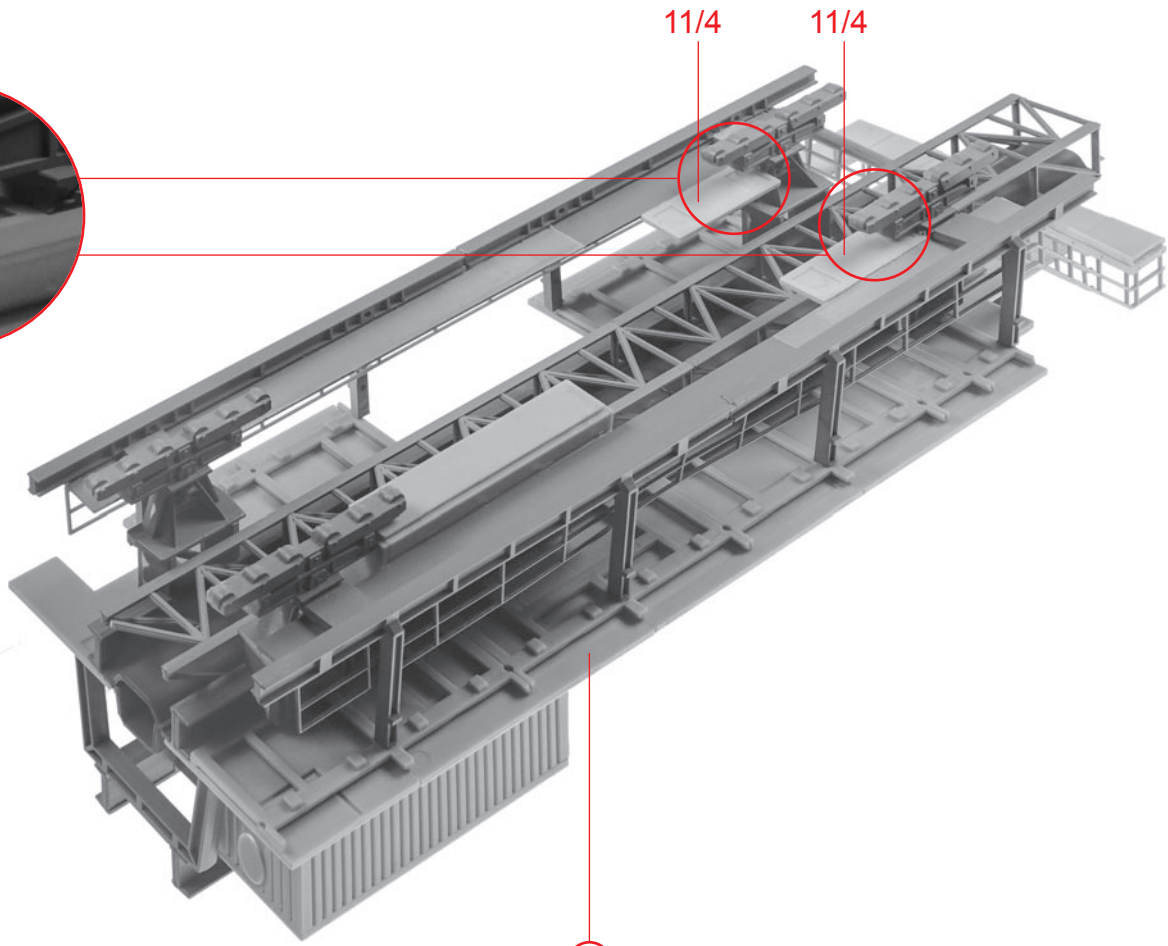
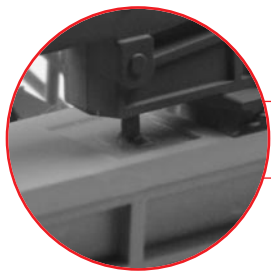

11/4

11/4

o

n

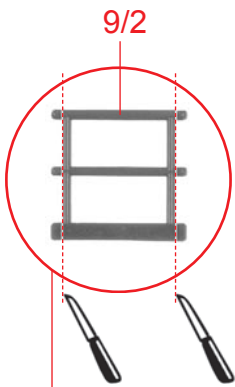

9/2

9/11

9/3

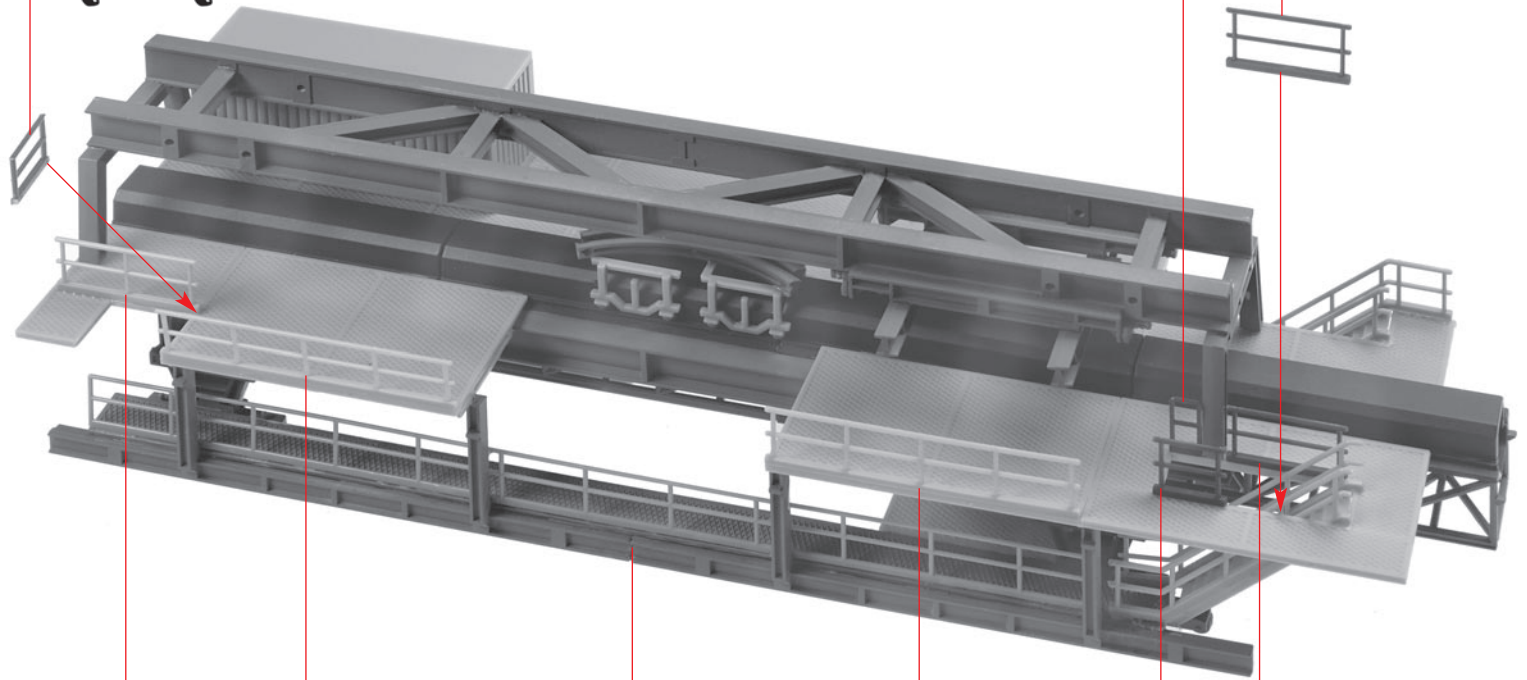

p

11/6

11/5

o

11/5

9/2

9/3

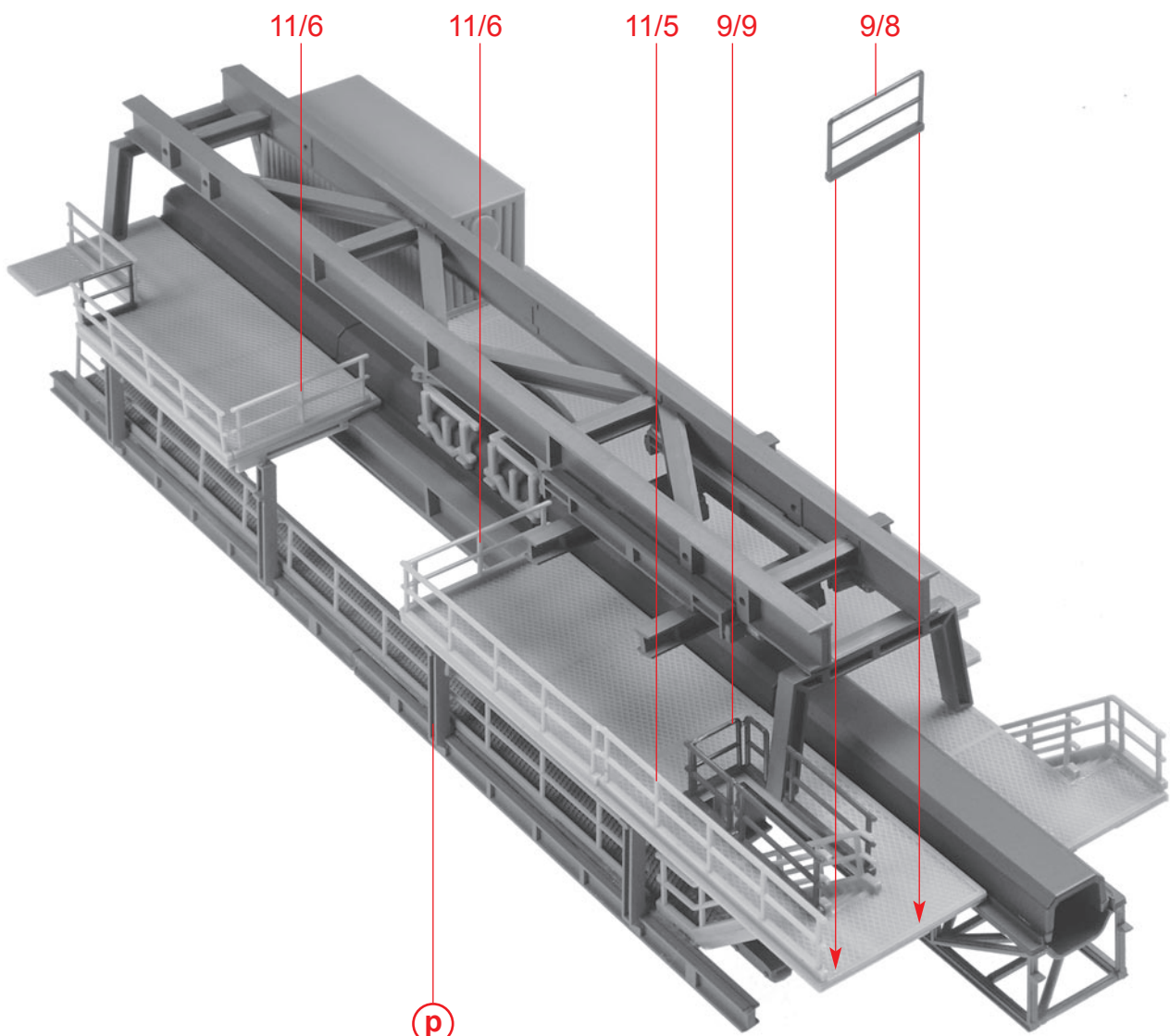

q

p

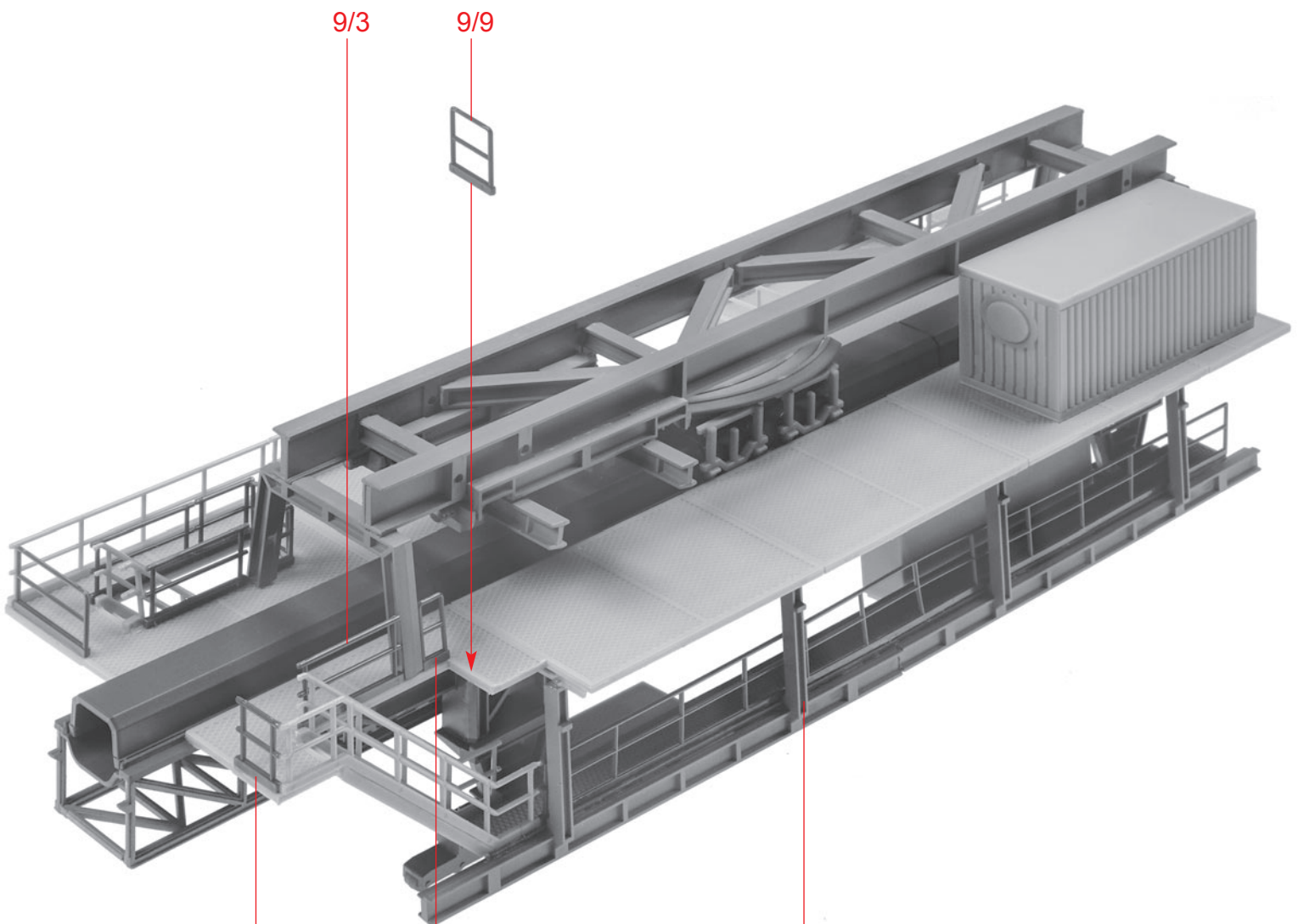

r

q

12/2

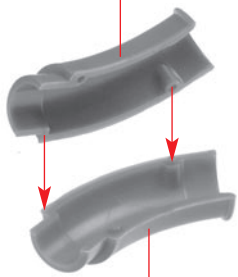

(A) 4 x 12/1

(A)



(B) 2 x **(A)**

12/4

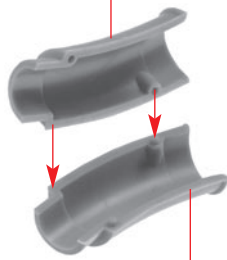

(C) 2 x 12/3

12/5

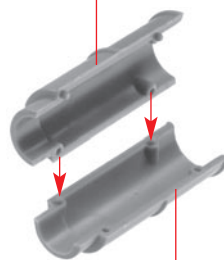

(D) 2 x 12/5

12/14

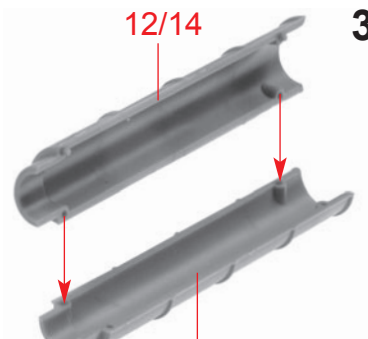

(E) 4 x 12/14

7/6

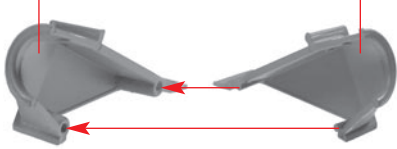

(F) 2 x

7/7

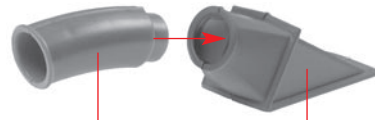

(G)

(C)

(F)

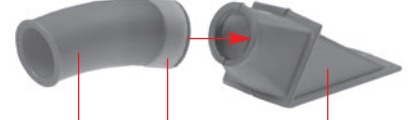

(H)

(C)

12/28

(F)

12/15



(I) 2 x

12/16

(B)

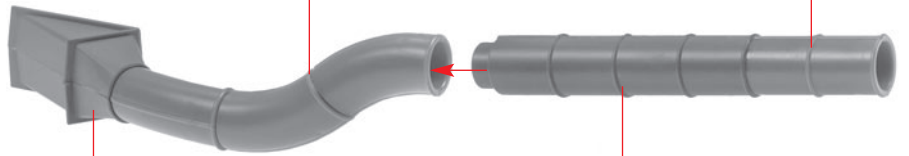

(J)

(G)

(E)

(D)



(K) **(I)**

(E)

(E)

(E)

(D)

(H)

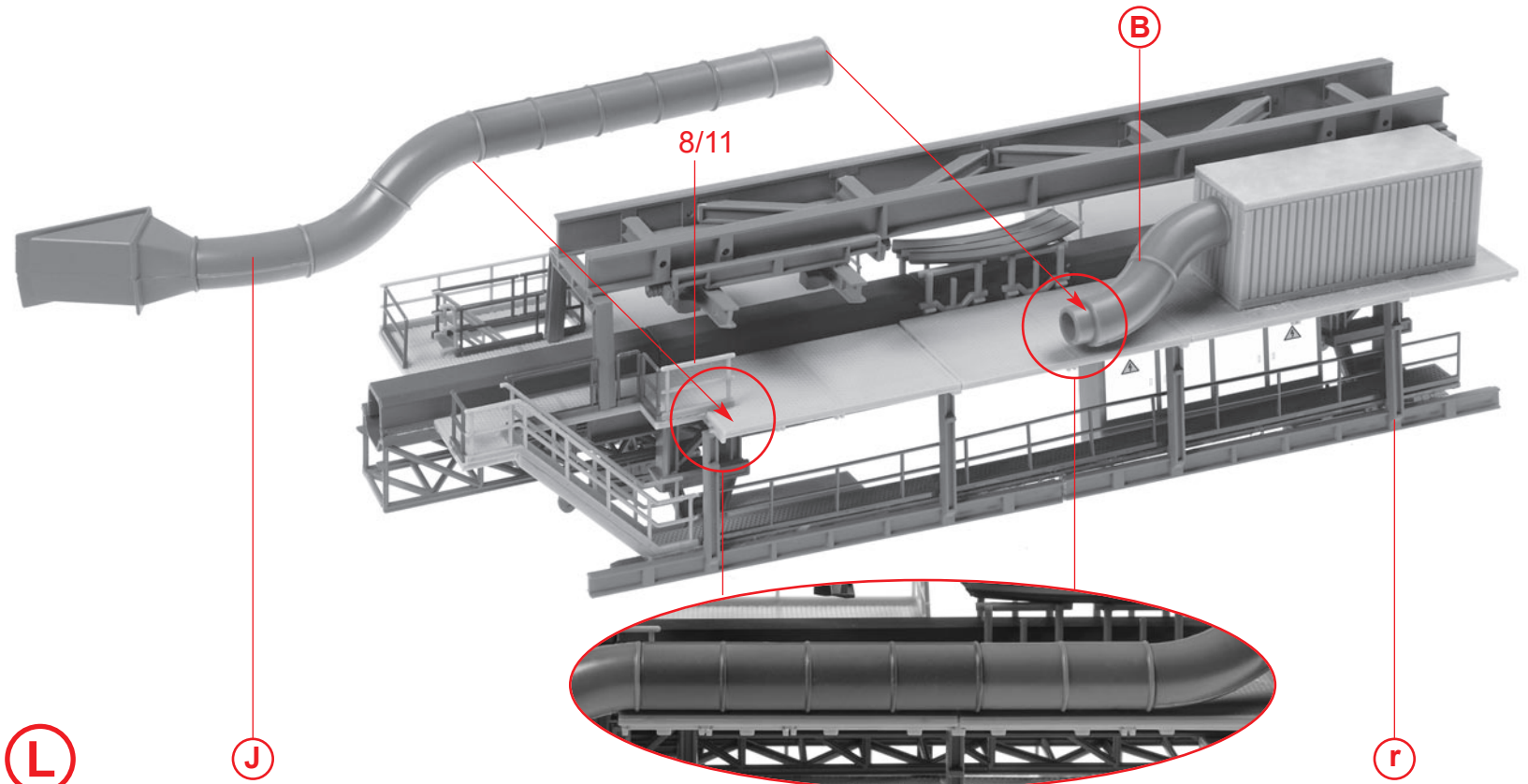

(L)

(J)

8/11

(B)

(r)

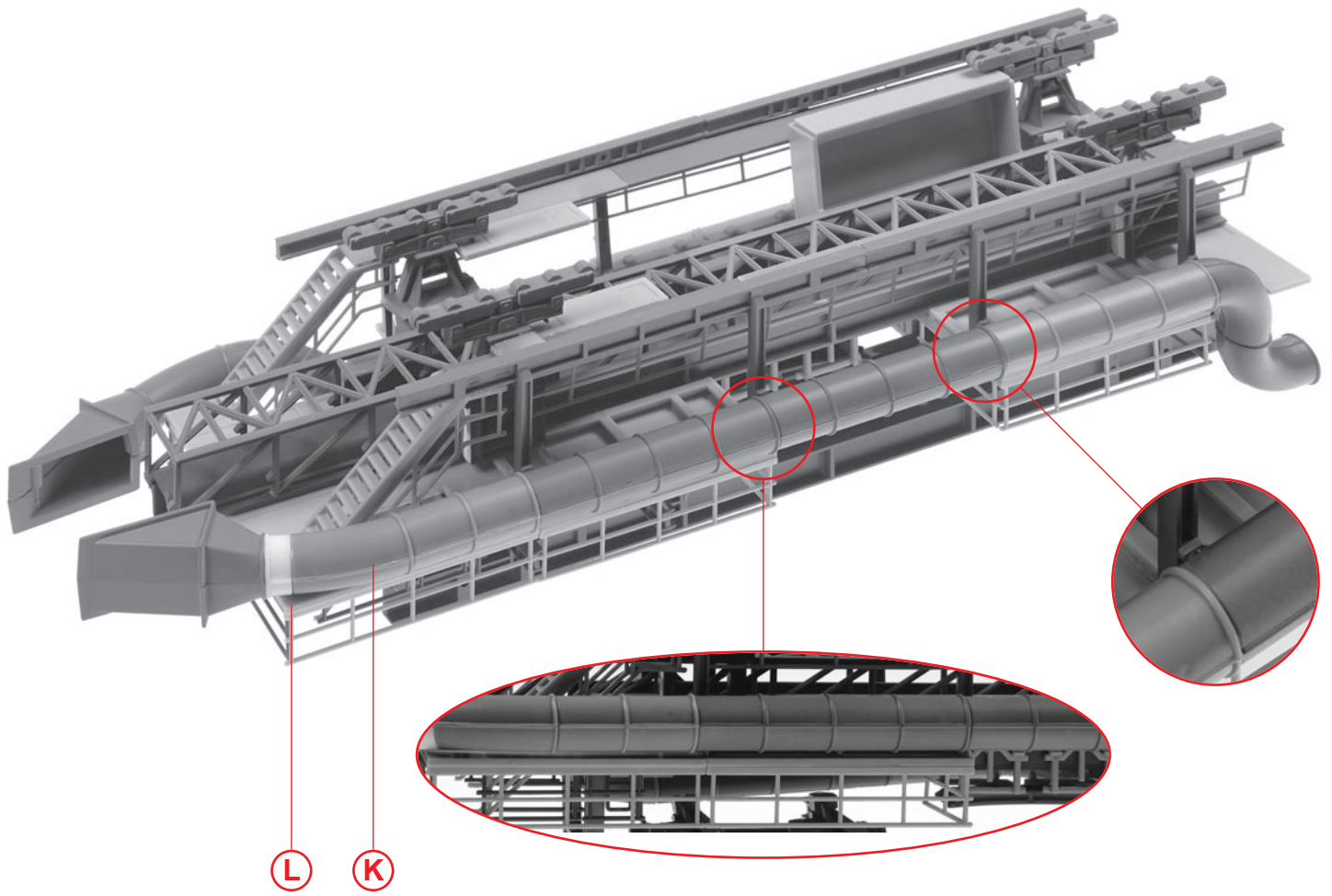

M

L

K

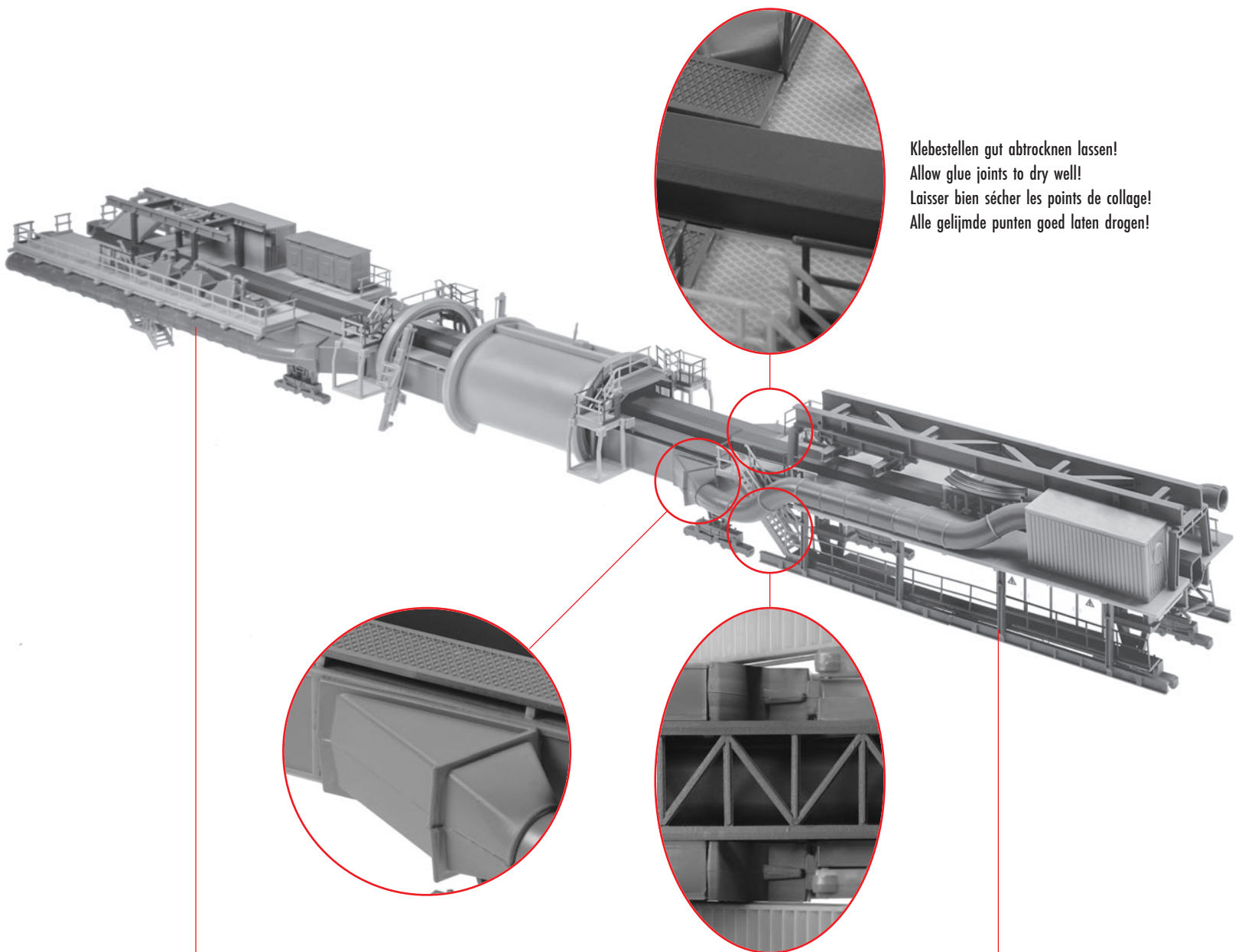

Klebestellen gut abtrocknen lassen!
 Allow glue joints to dry well!
 Laisser bien sécher les points de collage!
 Alle gelijmde punten goed laten drogen!

N

R

M

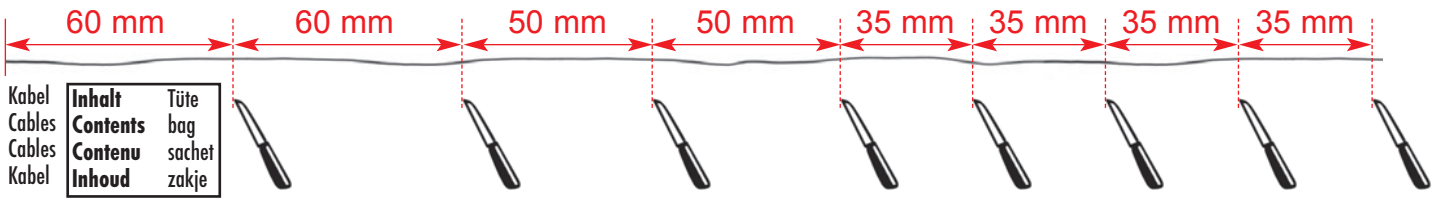

Kabel	Inhalt	Tüte
Cables	Contents	bag
Cables	Contenu	sachet
Kabel	Inhoud	zakje

35 mm   50 mm

Sekundenkleber verwenden.
Use instant modelling cement.
Utilisez la colle rapide.
Gebruik secondenlijm.

Kabelverlegung
Installation of cables
Installation des cables
Montage van de kabel

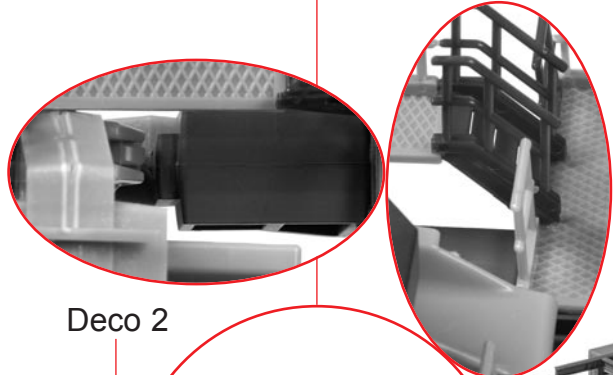
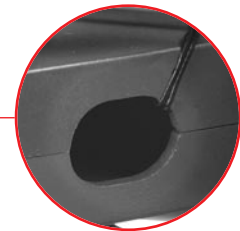
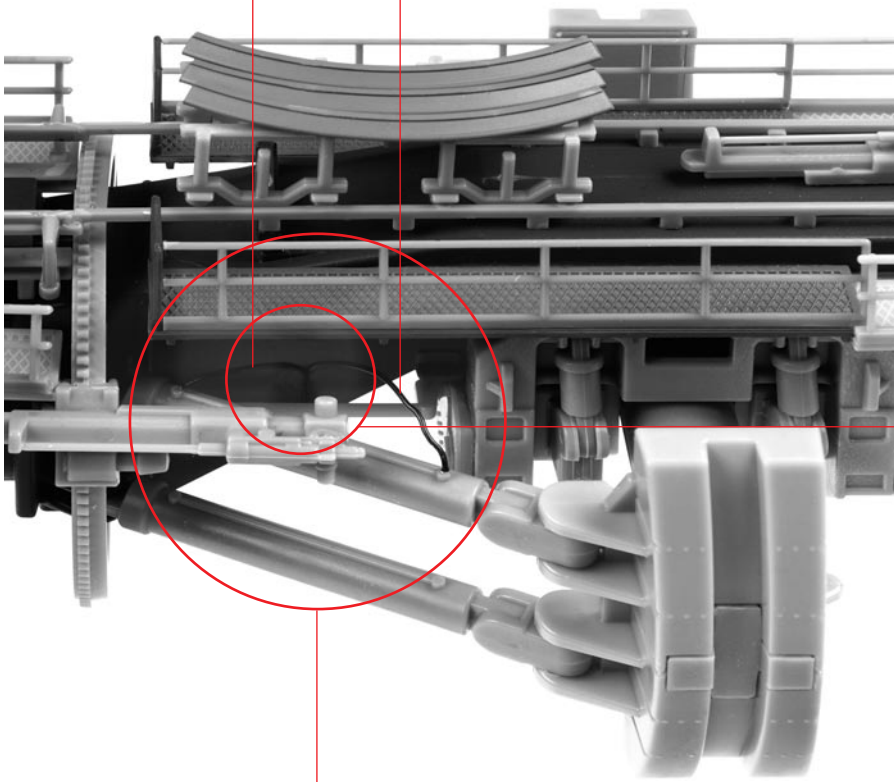

Deco 2

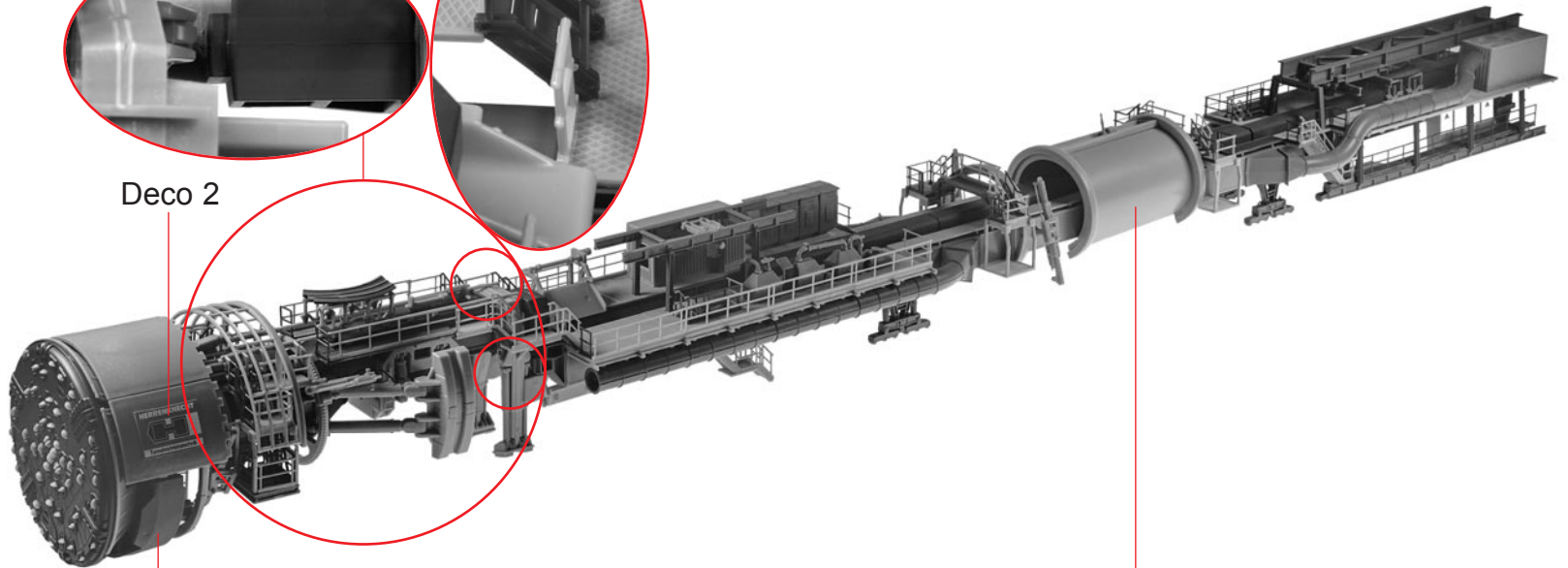

35 mm ○ 60 mm

Sekundenkleber verwenden.
Use instant modelling cement.
Utilisez la colle rapide.
Gebruik secondenlijm.

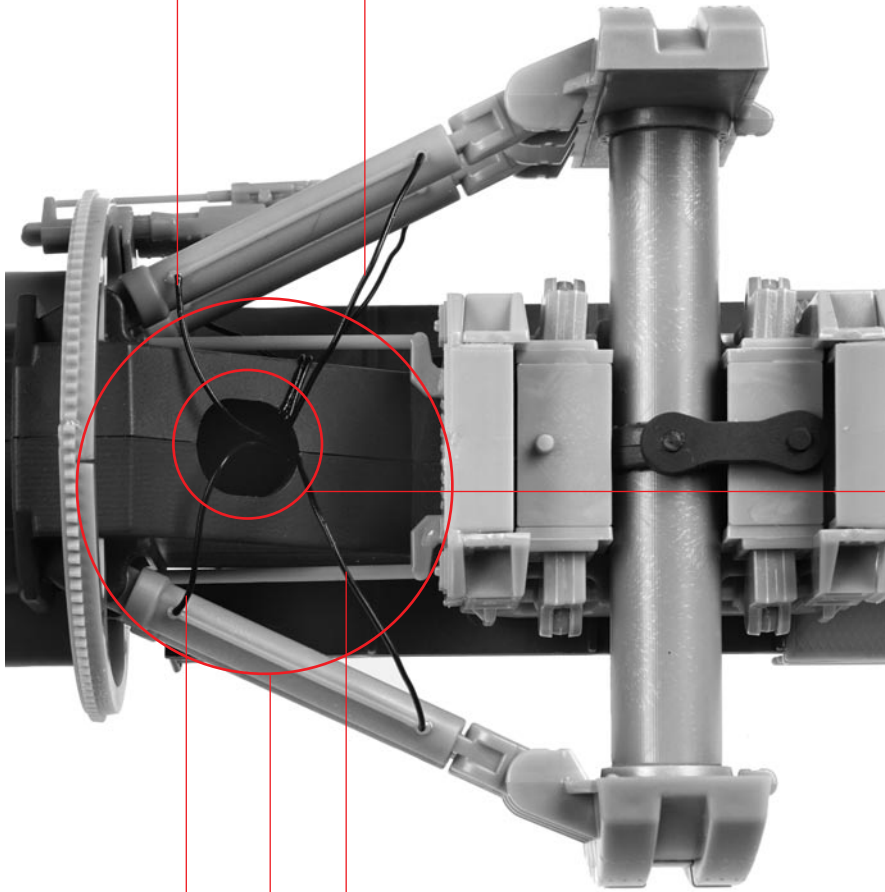

Kabelverlegung
Installation of cables
Installation des cables
Montage van de kabel

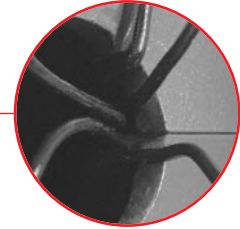

35 mm ○ 60 mm

Sekundenkleber verwenden.
Use instant modelling cement.
Utilisez la colle rapide.
Gebruik secondenlijm.

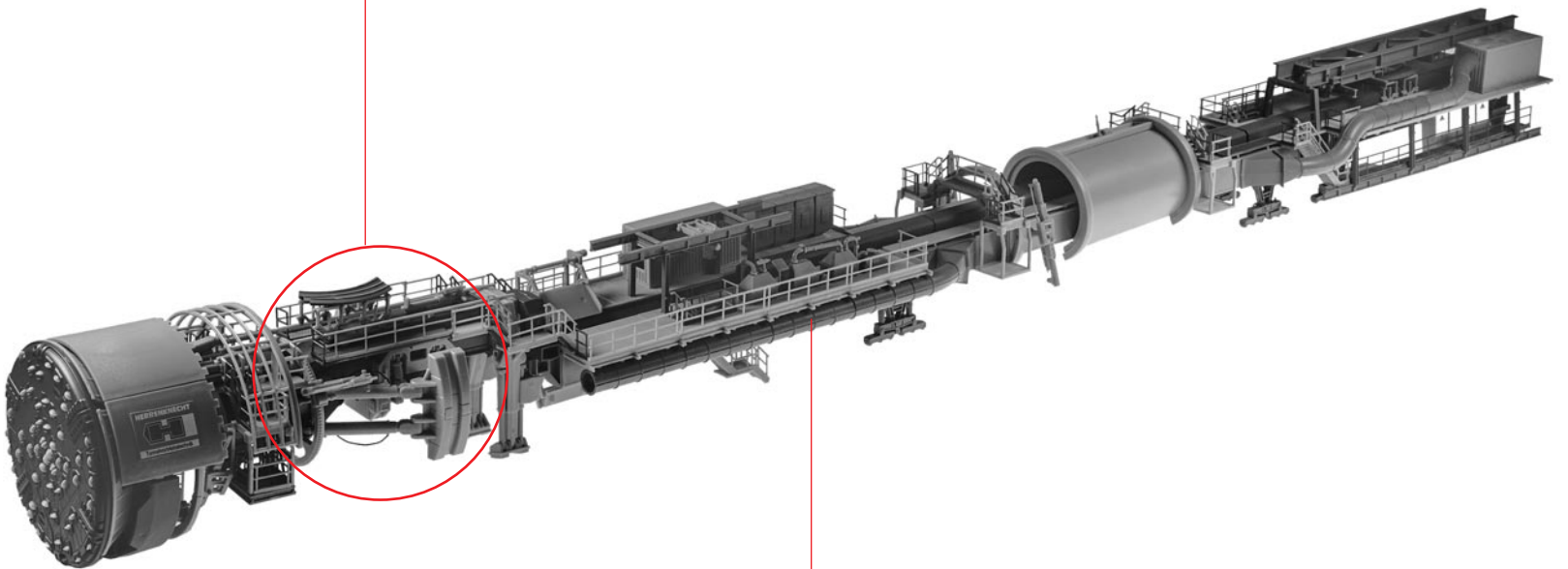

50 mm 35 mm

Sekundenkleber verwenden.
Use instant modelling cement.
Utilisez la colle rapide.
Gebruik secondenlijm.

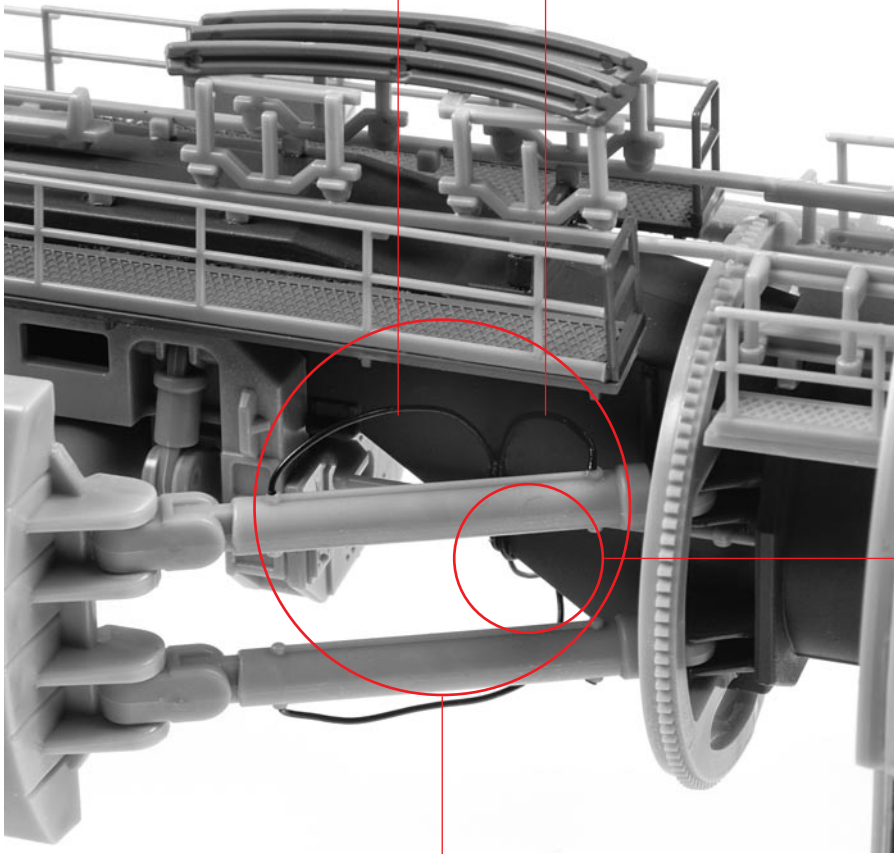

Kabelverlegung
Installation of cables
Installation des cables
Montage van de kabel

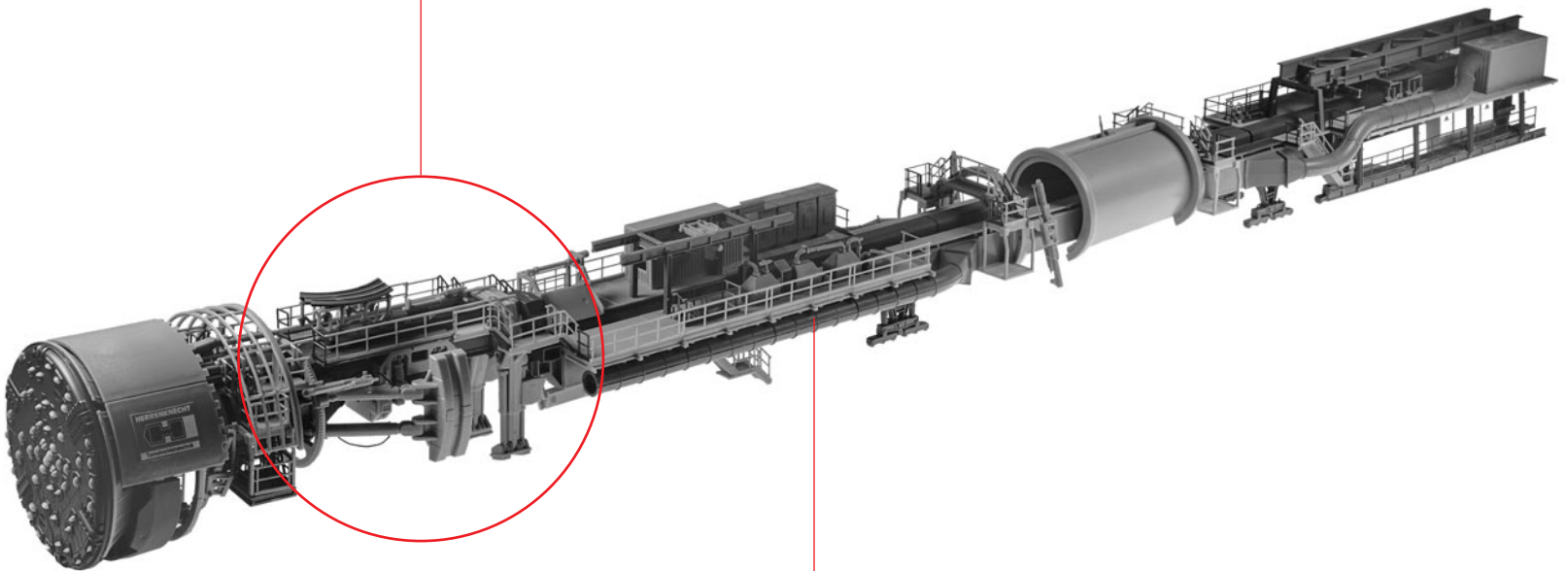
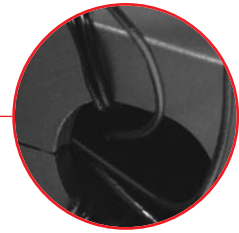

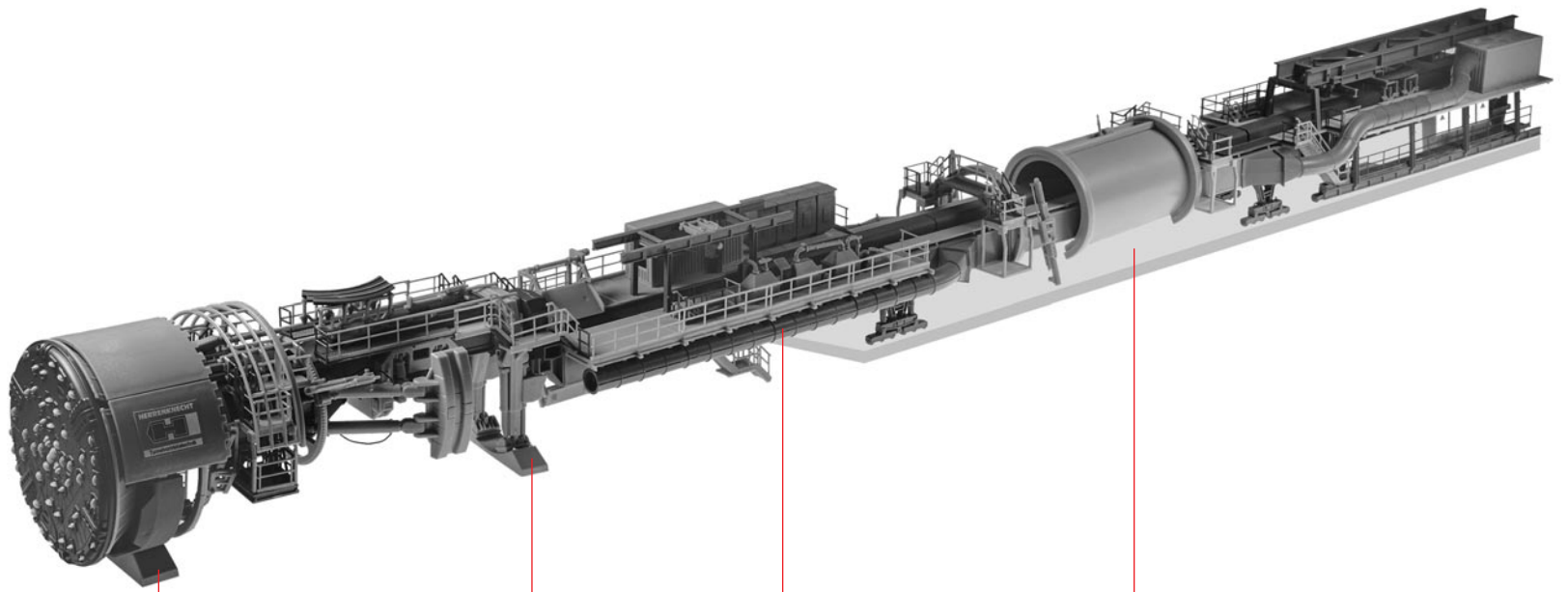

S

2/4

nicht kleben
do not glue
ne pas coller
niet lijmen

Variante

2/4

nicht kleben
do not glue
ne pas coller
niet lijmen

R

Plattenhöhe (liegt nicht bei): 6,7 mm
Plate height (not included): 6.7 mm
Hauteur du plateau (non jointe) : 6,7 mm
Plaathoogte (niet bijgevoegd): 6,7 mm

Drehrichtung
Direction of rotation
Sens de rotation
Draairichting



Ergänzungs-Set: Nachläufer für »Gripper-TBM«, Art. 130899 mit weiteren Nachläufervarianten separat erhältlich.
Supplementary set: Trailers for »Gripper TBM«, Art. 130899 with further trailing unit variants available separately.
Coffret complémentaire: Remorque pour le »Gripper-TBM«, Art. 130899 avec d'autres variantes de remorques disponibles séparément.
Aanvullende set: Naloper voor »Gripper-TBM«, Art. 130899, met meer volgwagenvarianten is apart verkrijgbaar.

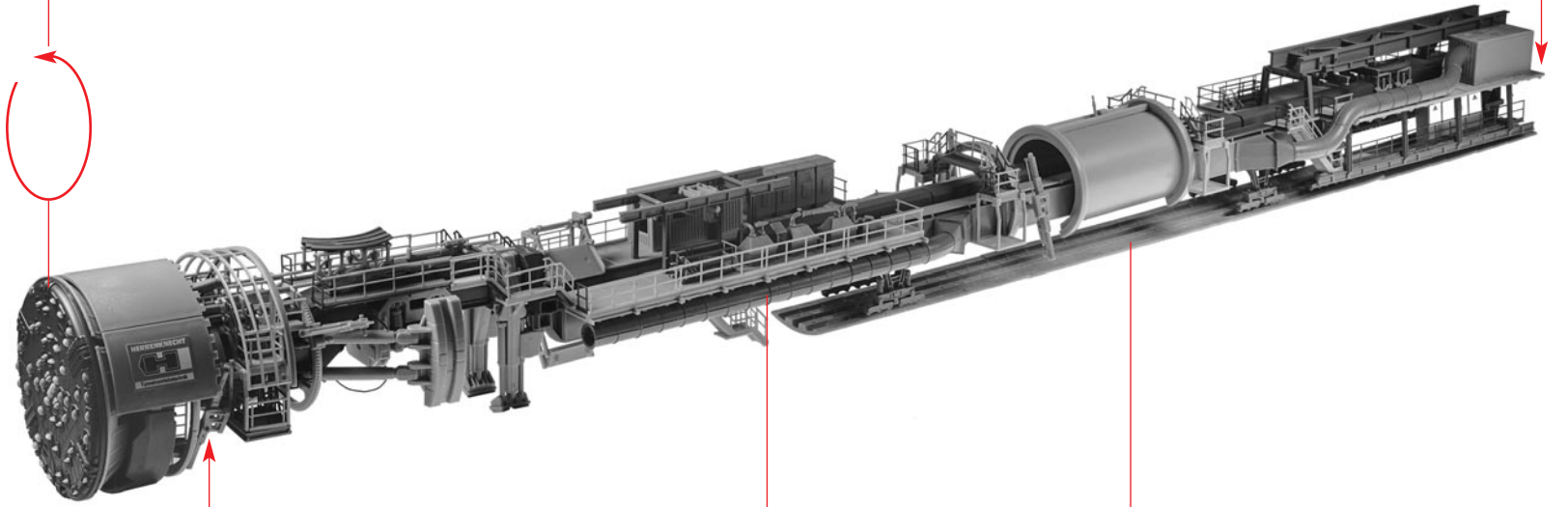

T

Der Anschluss erfolgt an max. 5 V Gleichspannung.
The connection is made to max. 5 V DC.
L'alimentation électrique est de 5 V CC.
Aansluiten op max. 5 V gelijkspanning.

R

Variante: 41 x 7/30

nicht kleben
do not glue
ne pas coller
niet lijmen