



HO Scale Structure Kit 933-2954

FREIGHT HOUSE

Thanks for purchasing this Cornerstone Series kit. All parts are made of styrene plastic, so use compatible glue and paint to finish your model. Please take a few minutes to read these instructions and study the drawings before starting. **PLEASE NOTE:** This kit can be constructed as a freestanding building or attached to the Freight Office (#933-2953, sold separately). If you are building a combined structure, follow these instructions and use the parts included with this kit.

For decades, the movement of small freight shipments was critical to a railroad's financial success. Railroads were the best all-weather, long-distance transportation system available and became THE way to ship virtually anything. But moving individual packages was a slow and complex operation as every item had to be handled many times. Mountains of routing slips, waybills, checklists and other paperwork were needed and they required an army of clerks to process and maintain. As single items, they were classified as less-than-carload lot (lcl) shipments; while each item didn't require its own car, they were sorted and grouped by destination then reloaded into a single car for their trip.

In small towns where there were few customers, freight shipments were handled at the local depot, usually a small "combination station," so called because freight, passenger and office facilities were combined under one roof. In towns with more business and small industries, railroads often constructed separate freight houses. Here, cargo could be stored securely and transferred easily between road and rail for local delivery. The biggest freight houses were found in major cities, where railroads often needed separate facilities

for lcl shipments moving in freight trains and express business handled aboard passenger runs. Big city operations generated so much paperwork that they required a dedicated office area. This was usually attached to the freight handling buildings, but some were freestanding structures located close by.

In the years following World War II, competition for lcl traffic grew dramatically with the arrival of newer and bigger trucks, and commercial airlines. This led many railroads to look at ways of modernizing and improving their service. Colorful express service boxcars appeared on some roads, while others ran dedicated trains that rushed lcl freight between major terminals. Other changes were also taking place, as lessons learned about logistics and shipping during the war years, such as the use of pallets and forklifts to handle cargo, were adapted to civilian industry.

As a result of all the hands-on operation, these big city facilities were open around the clock. This also kept items moving in tune with the schedules of the railroads, for packages had to be sorted, processed and reloaded by a set time each day in order to be on the trains. This also allowed packages to be ready for pickup at certain times, allowing an extra measure of service for larger customers.

While the railroad package business was a good system (and served as the model for today's parcel delivery services), it was just no match for the advantages of local and long-distance trucking and most railroads were out of the lcl business by the 1960s.

ON YOUR LAYOUT

Based on a Milwaukee Road facility located a few blocks south of the main

passenger station and close to both the central business and industrial areas in Milwaukee, Wisconsin, this kit is similar to freight houses used by many railroads.

Its brick construction and detail fits any era from the early 1900s to the present. The building can be combined with the Freight Office (#933-2953, sold separately) to model a typical city freight handling operation. By itself, this structure is also an ideal addition to heavy industry such as steel mills, assembly plants and railroad yards where they serve as warehouses.

Being 24-hour operations, these facilities were well lit inside and out. Exterior lights can be modeled with Wall Mounted Lights (#933-1094 or #933-2310) over the entry and dock doors.

Shipments to and from these facilities included virtually anything that could be loaded in a boxcar or reefer; facilities handling express shipments would also service a wide range of baggage cars, express boxcars and express reefers that typically moved on passenger trains.

Detailing the interior or the loading dock areas of your new building is easy with SceneMaster™ accessories including the Forklift with Crates & Barrels (#433-1619), the Vertical Crates (#433-1664) and the Loading Dock Set (#433-1678).

See your dealer, check out the latest Walthers HO Scale Model Railroad Reference book or visit walthers.com for more ideas to detail your new model.

Note: If you are combining with Freight Office (#933-2953) or multiples of this kit, observe the special directions.

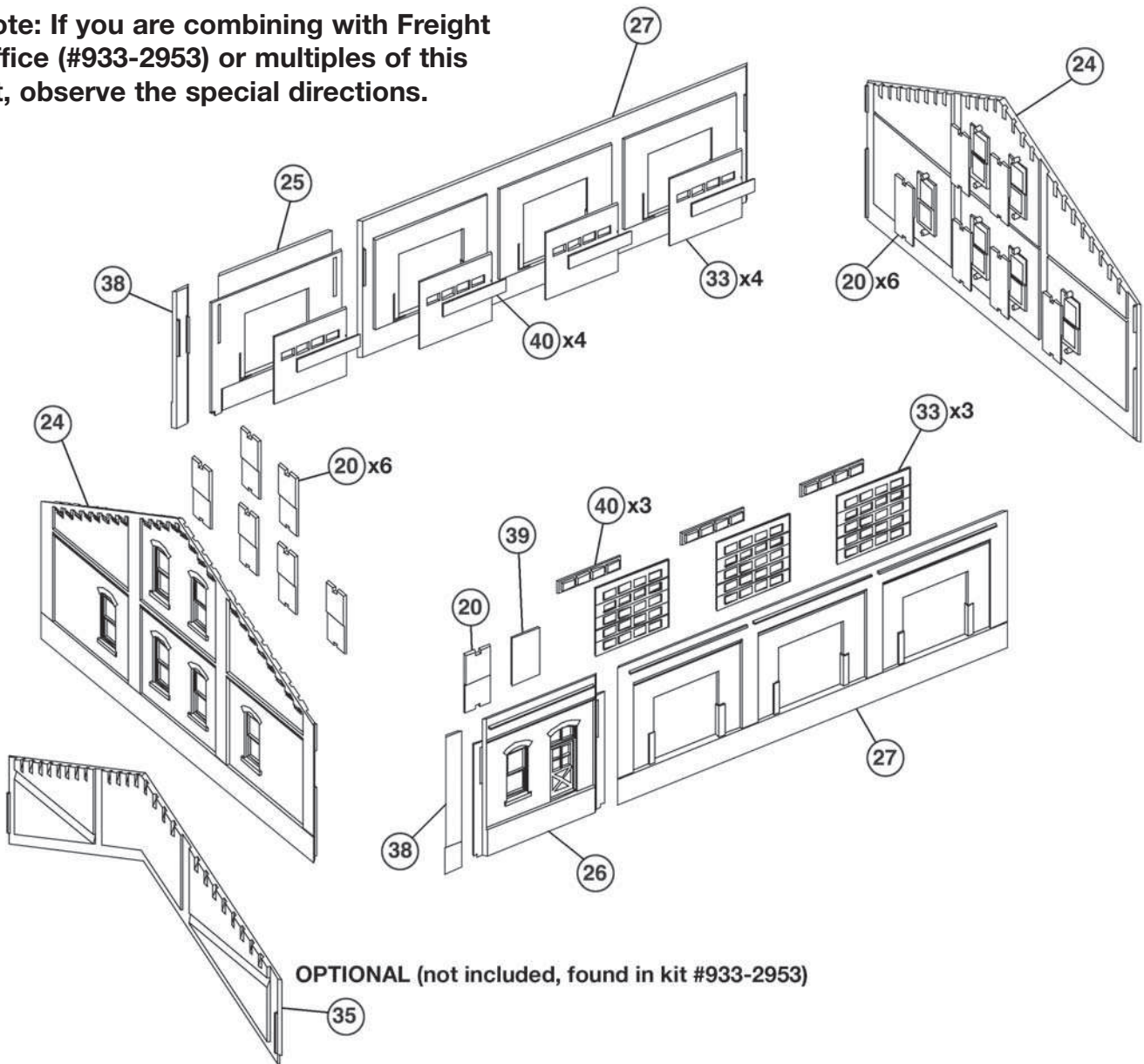

1. Glue the window “glass” (20) in place on the backs of the end walls (24). Note: If you wish to combine this kit with the Freight Office 933-2953 (sold separately), substitute wall #35 for one of the end walls (24) which must be glued on the office building.

2. Glue the “glass” into the windows on the backs of the freight doors (33). Then glue the doors in place in the backs of the walls (25, 27).

3. Glue the window “glass” (20) and door “glass” (39) in place on the back of wall #26.

4. Glue the side walls (25, 26, 27) together and glue the end pilaster (38) at the end of short wall #25 or #26 as illustrated (use #38 only when building a free-standing structure, not when combining kits). Note: The short walls (25, 26) are interchangeable depending on if you want all freight doors or a combination.

IMPORTANT: If you are combining structures, parts #25 and 26 must always be on the office end of the wall.

5. Glue the base (34, 37) together. Note: Besides being able to combine this building with the Freight Office (933-2953 – sold separately) it can also be expanded lengthwise when combining multiples of this kit (sold separately). If you wish to combine with the Freight Office, leave base piece (37) off the end where the office will go. When expanding lengthwise, leave off base piece (37) where the side walls are joined and glue bases #34 end-to-end.

6. Glue the walls together and to the completed base.

7. Glue the roof (36) together and on top of the walls. Note: There are cutting grooves found on the underside of #36. If you are combining with the Office, cut the roof off at the inside roof groove at the end where the buildings meet and glue the roof on top of the ridge found on part #35. If you are lengthening the sides, trim the roof at the outside roof grooves and glue the roofs end-to-end.

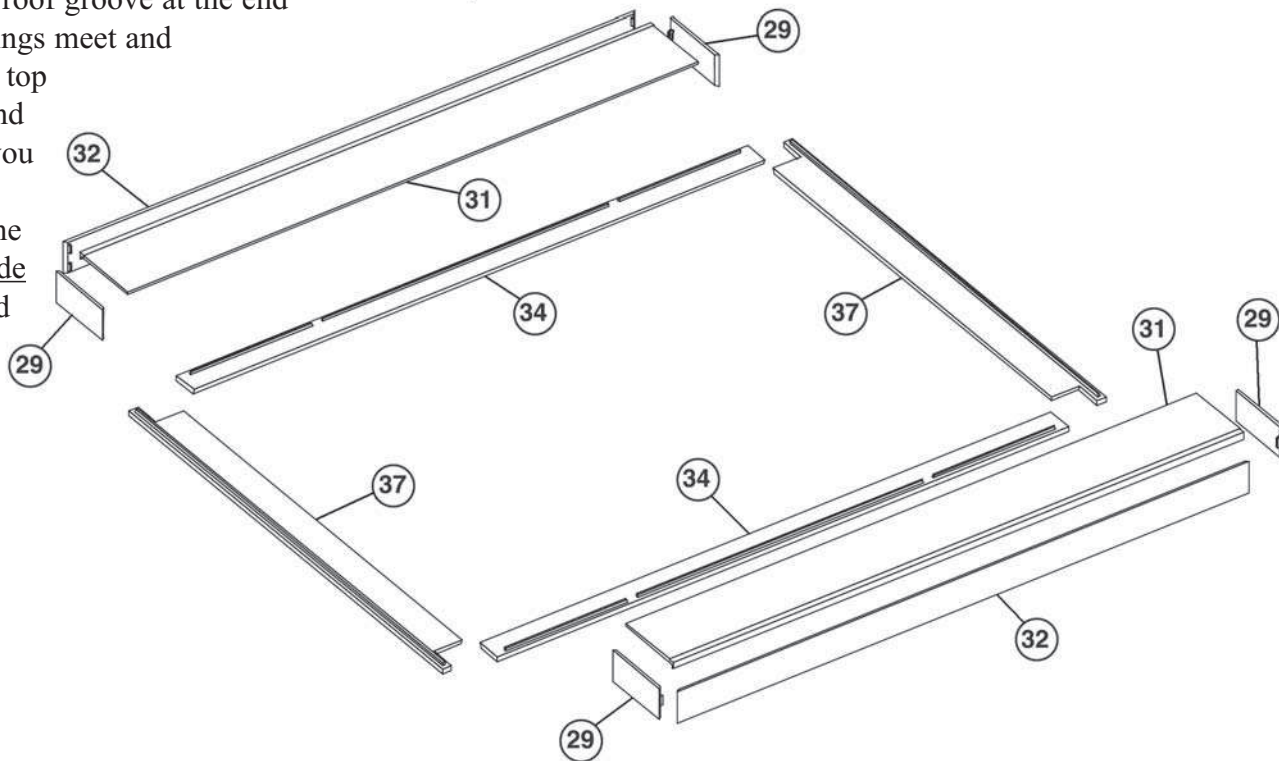
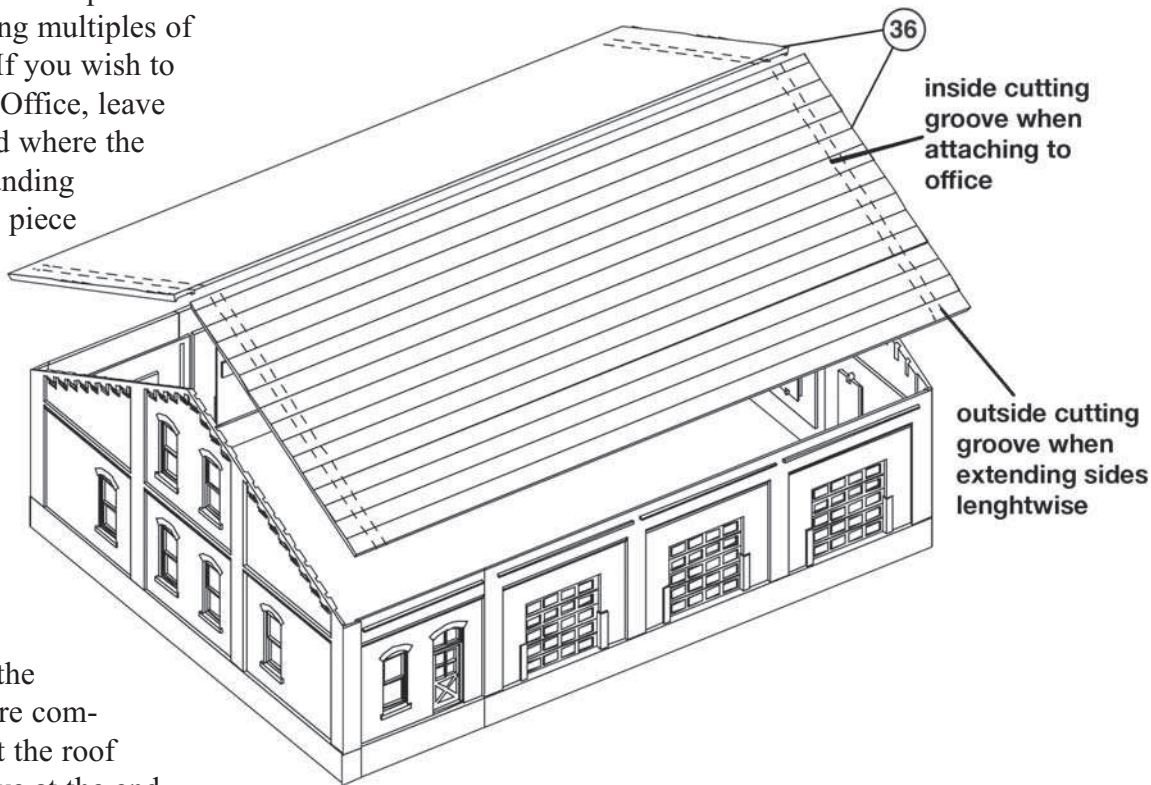

Expanding walls and roofs lengthwise using multiple kits

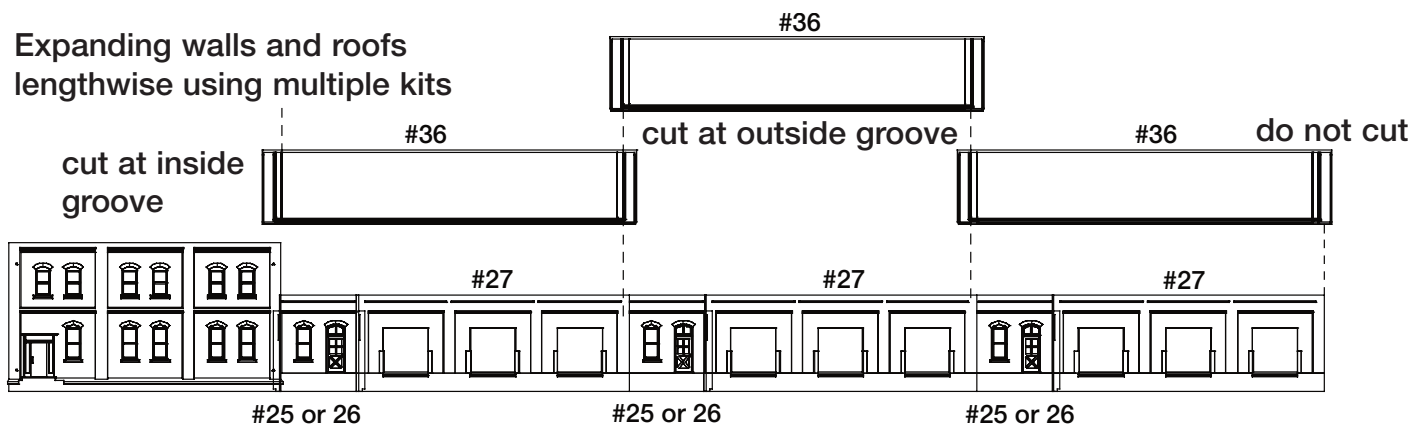

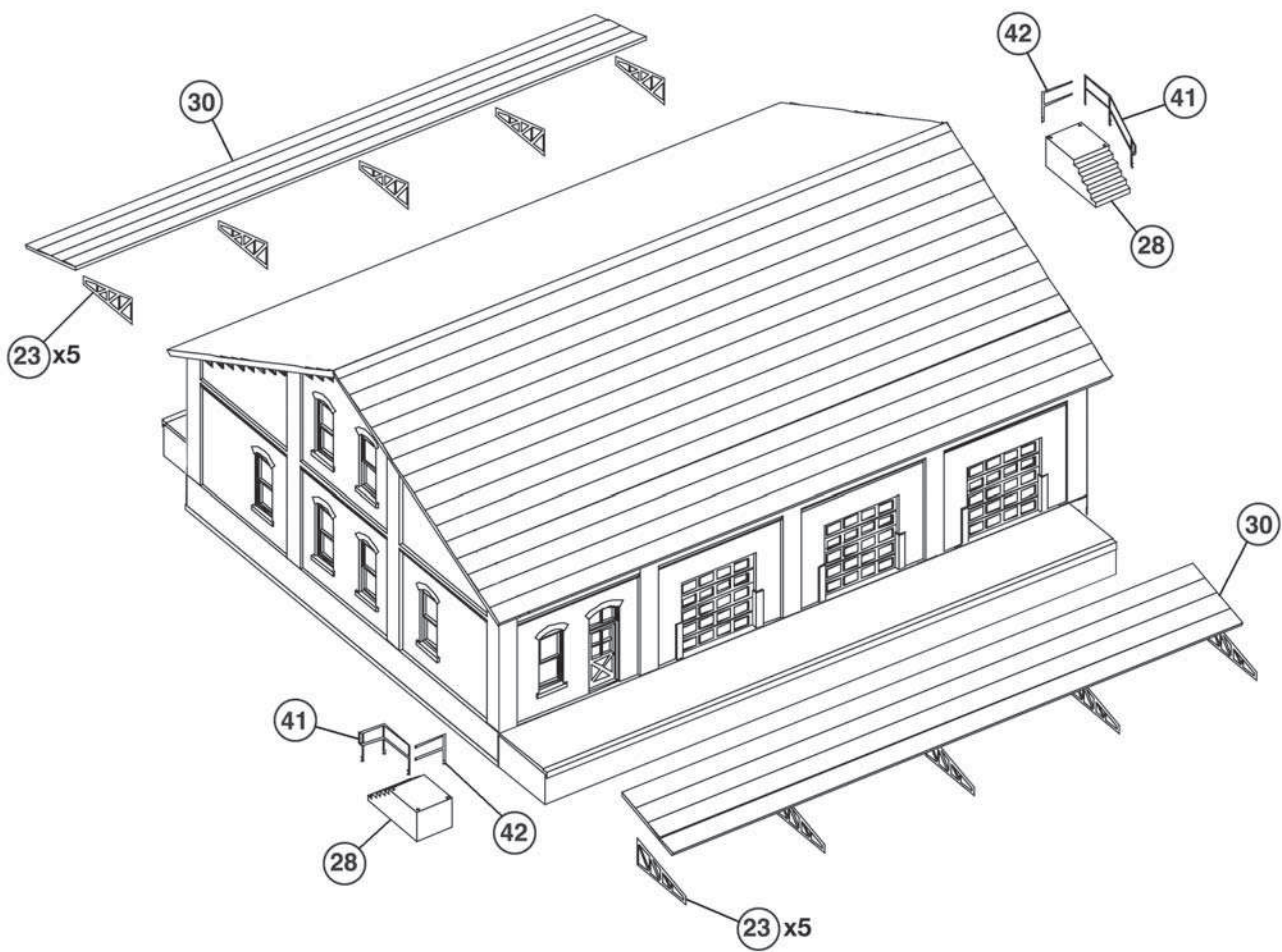

8. Glue the loading dock (29, 31, 32) together and then to the side walls under the freight doors.

9. Glue the canopy supports (23) underneath the canopies (30). Note: The supports go in between the ridges found on the underside of the canopy. Then glue the completed canopies on top of the ridges found on the side walls.

SIGNS

To mount signs, simply cut the desired name and, using a small drop of white glue on the back, glue it in place.