



HO Structure Kit CONCRETE COALING TOWER 933-3042

Thanks for purchasing this Cornerstone Series kit. Please take a few minutes to read these instructions and study the drawings before starting. All parts are made of styrene plastic, so use paints and glues which are compatible.

Your finished model will be a distinctive addition to any engine servicing facility on your railroad. This 150 ton capacity tower, based on a prototype built by the Ogle Construction Company, was ideal for servicing medium sized and most large engines. The design is typical of those used by many roads and could be found in terminals, along the main line, or on a busy branch line. It can serve from the 1920s to the end of steam around 1960. Due to the expense of demolishing them, many concrete towers stood long after their service lives were over. For this reason you could make this structure part of a modern scene by leaving off the metal details and weathering it to show years of neglect.

Consult the current HO Model Railroad Reference Book for additional structures and details to model a complete engine servicing facility. You can also find these at www.waltherscornerstone.com.

SHED ASSEMBLY

Glue the shed windows (85) into the front wall (26) and the door (86) into the side wall (27). Glue the walls (26, 27, 28, 29) together and to the base (90). Add the roof (30) and attach the chimney (87). Set aside for later instruction. The position of the shed can vary somewhat. Position it between the main track and the coal delivery track.

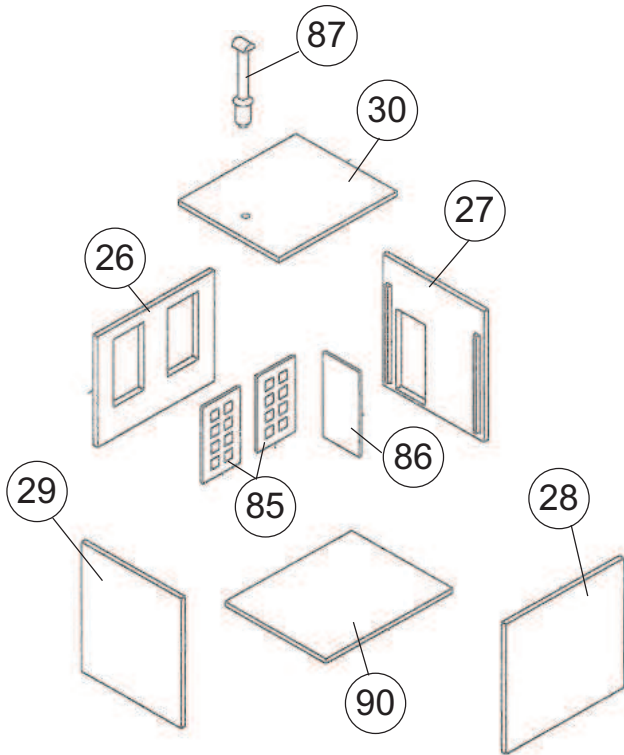

COAL UNLOADING SHED ASSEMBLY

Glue the coal unloading shed sides (31) to the shed foundation sides (23 and 92). After the sides have dried attach the shed floor (25) and the ends (24) to one side and then to the other. Now glue the end pieces (32) and the roof trusses (34) to the slots along to top edge of the sides. Attach the roof pieces (33) to the ends and the sides. Set aside to be used in later assembly. After the Coaling Tower is assembled, Position the dump shed against the skip hoist side of the tower. Foundation side 23 has a notch along the bottom to fit against tower base 1 and locating lines for hoist base sides 21 and 22. Glue if desired.

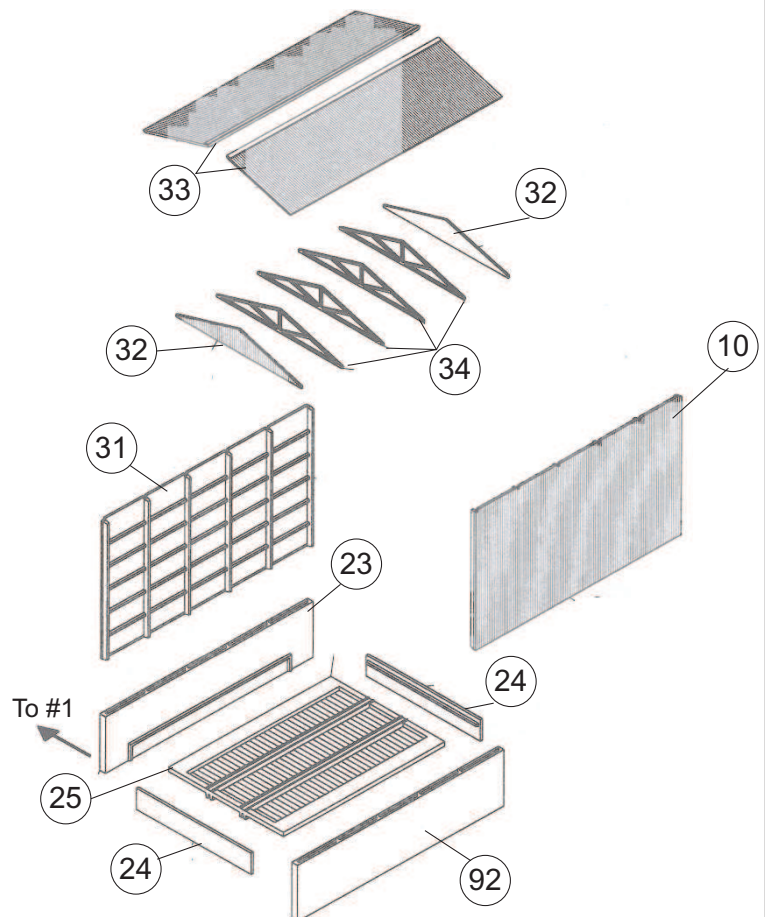

1. Begin by gluing the outer support ends (3) to the outer sides (5 and 6). Then glue the inner support ends (4) into place. Now add the inner support sides (7) and the small end pieces (91), making sure all the parts are flush along the bottom. Glue the support structure to the bases (1 and 2). Glue two crosspieces (8) together and attach to the support structure on the hoist side as shown. Glue the support top (10) in place, and then add the two gusset pieces (11) to the underside of the support top. Do not glue the support ceiling (9) in place yet.

2. Assemble the straight hopper for the outside track chute (73, 74, 75, 76) and L-shaped hopper for the inside track chute (58, 59, 77, 78, 80) and attach them at the raised pads on the underside of the support ceiling (9). Next assemble two chutes from parts 81, 82, 83 and 84. Slip (do not glue) the pivot pins on the sides of the chutes into the holes in the hoppers. You may wish to tie two lengths of thread about 1-1/2 inches long, as shown in the illustration, to the inner chute before installing it. The threads may be pushed through the holes in part 9 and fastened to the upper side with small pieces of tape to hold the chute in the position you want. If you wish to have the chute in the down position (45 degrees downward), make sure it will clear any rolling stock you might operate under it. Glue the support ceiling in place, noting the orientation of the hoppers.

3. Attach two upper platform brackets (67) outside of the locating lines on part 5 of the support structure. Add the railings (50 and 66) to the platform (65), then glue the platform to the brackets leaving space for bunker wall (13, added later). Attach the lower platform (61) to the support structure and then add the railing (62). On the lower ladder (60) note that there are notches on the verticals near one end. Bend the ladder slightly here to match the angle at the base of the support structure. Glue the lower ladder to the support structure. The middle and upper ladders (63) can be added after the bunker is attached to the support structure.

4. Glue the hoist base sides (21 and 22) to the base and the support structure. Add 3 hoist brackets (35) to the support structure. Glue the ladder brace (57) at a 45-degree angle between the hoist base and the support structure, about 3/4 inch above the base. The ladder should be added after the hoist is assembled.

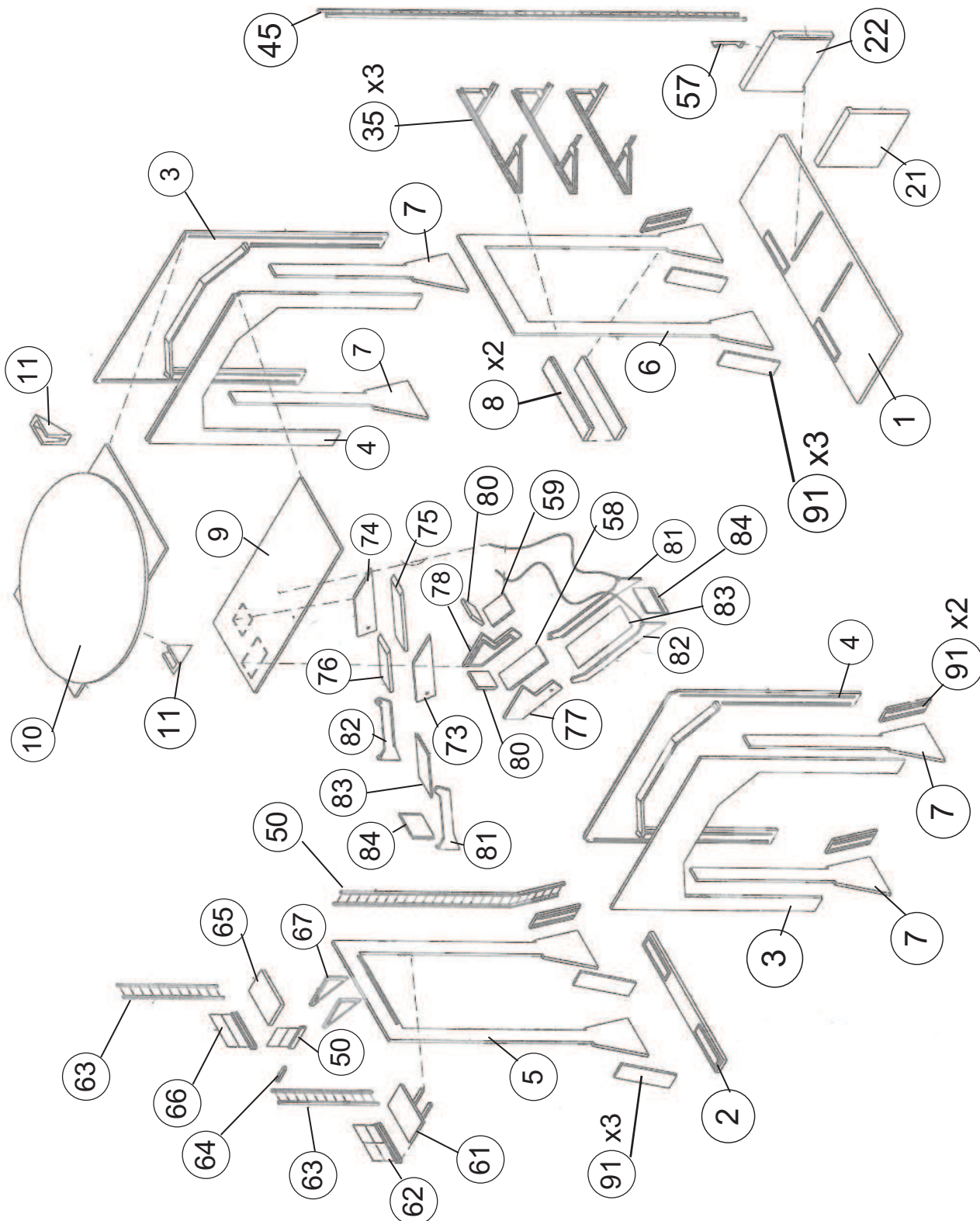

DECALING

1. After cutting out the decal, dip in water for 10 seconds, remove and let stand for 1 minute. Slide decal onto surface, position and then blot off any excess water.
2. Lightly brush Micro Sol® on top. This will soften the decal allowing it to conform to irregular surfaces. DO NOT TOUCH DECAL while wet!
3. When the decal is thoroughly dry, check for any trapped air bubbles. Prick them with the point of a small pin or hobby knife blade and apply more Micro Sol®.

5. Assemble the bunker sides (12 and 13) and attach to the support structure making sure the holes for the hoist brackets are on the same side as the brackets already in place on the support structure. Note that the 2 most widely spaced holes on part 12 are on top. Add the subroof (14) and the roof (15) to the bunker, lining up the flat edges toward the hoist location.

6. Glue the cupola door (86) to the inside of the wall (17). Glue the cupola walls (16, 17, 18 and 19) together and insert this assembly into the roof so that wall 16 faces the hoist location. The roof halves (20) may be left off until the skip hoist rigging is completed.

7. Attach the upper hoist brackets (36 and 37) to the bunker. Be careful not to remove the mounting pins from the outer sides of the brackets. The short angle irons, where the brackets meet the bunker side, should go on top. Remove any burrs from the insides of the hoist side rails (38 and 39) so that the skip bucket will slide smoothly. Insert the hoist side rails into the opening in the cupola side and glue them to the inner faces of the brackets (35, 36, 37), even with the outer ends of the brackets and touching the base. Add the rail spreader piece (40) to the side rails as shown. Assemble the skip bucket (41, 42). Glue the skip bucket crosspiece (43) to the bucket wheel frames (44). When the assembly has dried thoroughly, slip (do not glue) the pins on the insides of the wheel frames to the ends of the bucket. Then gently spread the hoist rails slightly and slip the bucket assembly into the channels. The bucket should be able to move up and down the rails.

8. Glue the large platform brackets (48) to wall 17 outside the vertical locating lines and flush with the top line. Then glue the platform (47) to the railings with the overhang toward the skip hoist. Then add the railings (49, 50). Similarly glue the small platform brackets (54) to wall 16 and then assemble the platform from parts 50, 51, and 53. Glue the hoist pulley halves (56) together, lining up the spokes. Place (do not glue) the pulley brackets (55) onto the pulley halves and glue the brackets to wall 16. Tie a length of thread to the eyelet on the skip bucket part 43 and run it up to the pulley. Insert the end through the hole in the wall and position the skip bucket where you want. On the prototype the bucket is usually out of sight in the dump pit under the shed. Tie a knot in the upper end of the thread inside the wall. Now you can add the hoist machinery access ladders (45, 46). Ladder 45 is glued to parts 35, 36, 37 and 57 so that the top rung is even with the platform on part 37. Ladder 46 is attached to part 37 and 47. Bend ladder 46 at the notches in the verticals so that the longer (lower) portion is vertical and the top meets platform 47.

9. The pulley system for the outside track chute should be assembled by gluing the pulleys (71) to the outer pulley brackets (69, 70). Insert pieces of thread into these assemblies before gluing the inner brackets (93, 94) in place. Using enough thread (about 4-1/2 inches per side, to allow for trimming) to connect to the chute, string the weights (89) and allow for full movement of the chute. Glue the completed pulleys to the pulley base (68) then attach the base to the side of the bunker above the outside track chute. There is a locating bump for this part. Now it is time to glue on the middle and upper ladders (63). The middle ladder should be attached so that there is about 5/32" (one rung space) between the bottom rung and the platform. Note the small brace (64) which goes between the outer top end of the middle ladder and the bunker side (note the 45 degree angle on one end). The upper ladder attaches to the platform and to part 68. Tie one end of each piece of thread to the eyelet on the corresponding chute side. Slip eight weights (89) onto the other end of each thread. The weights should be positioned to allow the chute to be positioned 45 degrees downward. The weights can be spaced about 1/16" apart for greater realism. They can be secured to the thread with medium-viscosity super glue. Take care not to get glue into the pulleys if you want the chute to be positionable.

