



HO Structure Kit **WOOD WATER TANK** 933-3531

Thanks for purchasing this Cornerstone Series® kit. All parts are styrene plastic, so use only compatible glue and paint. Please read the instructions and study the drawings before starting construction.

In the steam-era, water was essential to run a railroad. Locomotives worked hard and tenders had to be refilled constantly. Wood Water Tanks were typically located every 20 miles along the line, and railroads often built depots nearby. Some of these remote

stations grew into “tank towns” with a store and a few homes.

But not every tank stood singly. Busy terminals often required two or more tanks to service a fleet of thirsty road engines and switchers around the clock.

As larger tenders came into use in the 1920s, older and smaller tanks were often replaced with the larger style depicted by this model. Cheap to build and durable, many served until the end of the

steam era.

With additional buildings from the Trackside Structures Set Kit (933-3530), Golden Valley Depot Kit (933-3532) and Golden Valley Freight House Kit (933-3533), you can model a complete scene. For figures, vehicles and scenery materials, visit your local hobby shop, see the latest edition of Walther's HO Scale Model Railroad Reference Book or visit our Web site at waltherscornerstone.com.

1. Glue the frost box walls (2, 3) together.

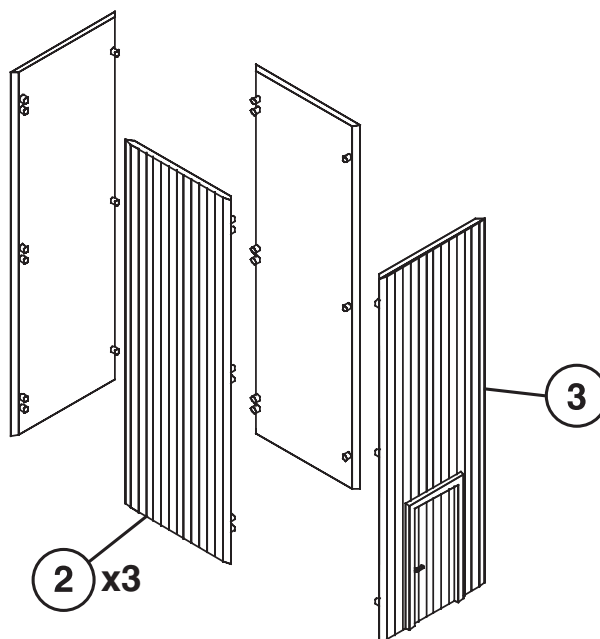

2. Glue the bracing pieces (8) to three of the four timber supports (4, 6, 7) as shown. Then glue the four together.
3. Place the frost box on the large pad of the base (1). Next, place the completed support assembly over the frost box, putting the bottom pegs into the holes in the small pads on the base. Glue those pegs in from the bottom of the base. This will hold the frost box in position.

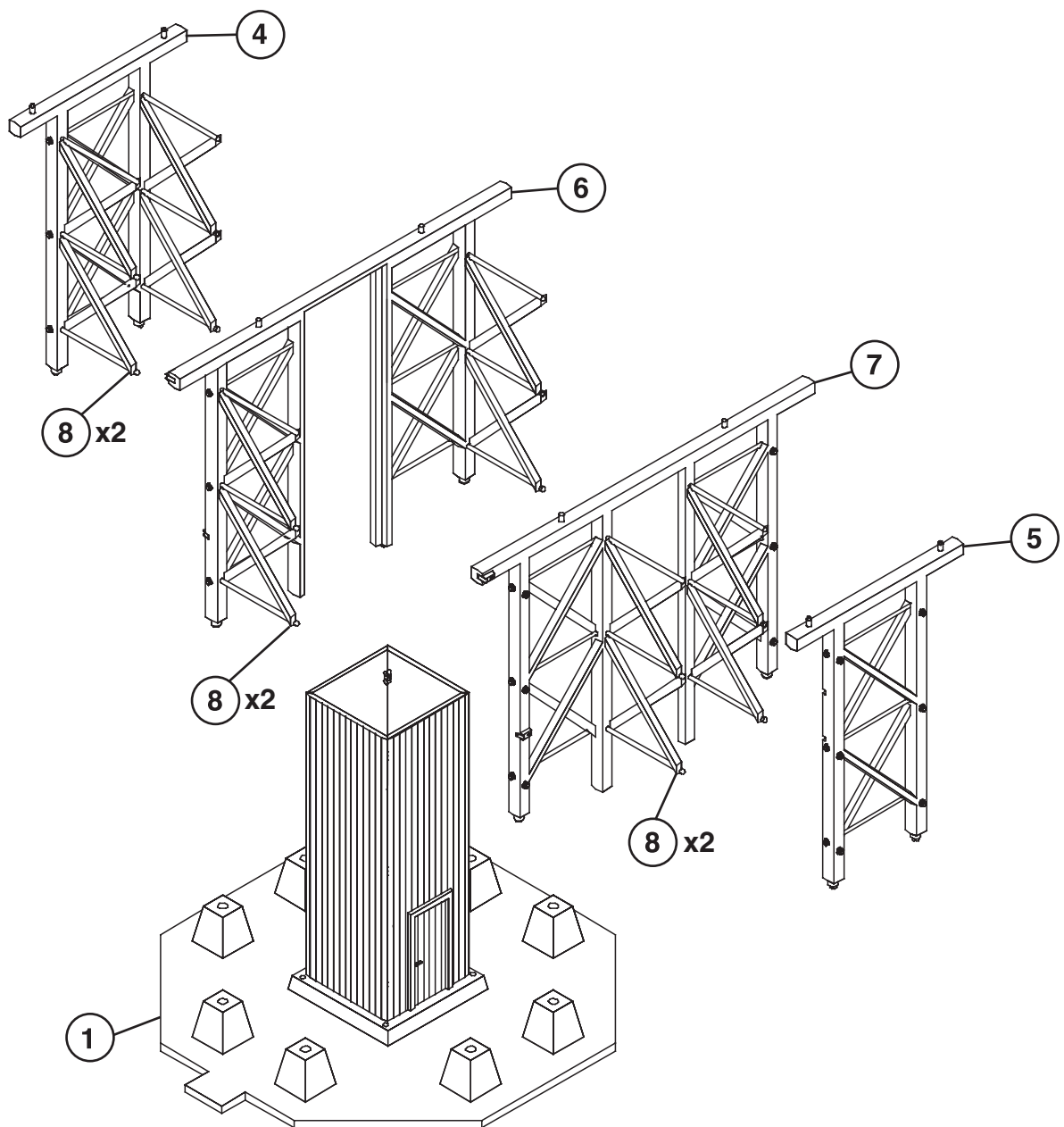

WATER GAUGE

- 1
- 2
- 3
- 4
- 5
- 6
- 7
- 8
- 9
- 10
- 11
- 12
- 13
- 14
- 15
- 16

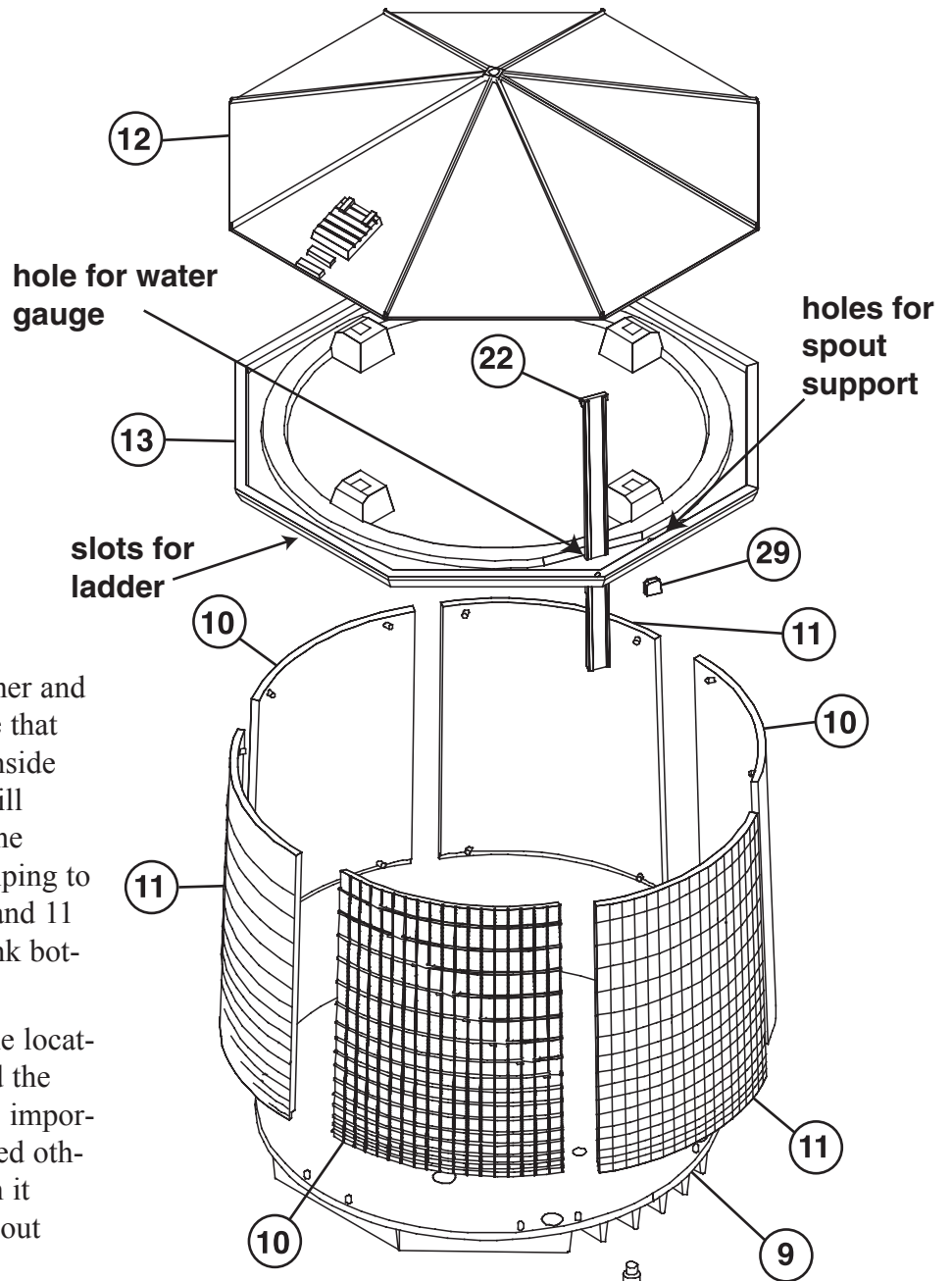

4. Glue the tank sides (10, 11) together and to the tank bottom (9). You will note that there are pegs protruding from the inside surface of these parts. Those pegs will straddle the vertical pegs found on the upper edge surface of #9 thereby helping to position the tank properly. Parts 10 and 11 alternate as they wrap around the tank bottom.

5. Glue the tank top (13) on using the locating pegs found both on the sides and the bottom surface of the top. Note: It is important that the top is put on as illustrated otherwise you will have problems when it comes to attaching the ladder and spout pieces.

6. Cut out water gauge from I-sheet and glue in place on part #22 using white glue. Poke a hole through the paper gauge where the level (29) attaches. Then, insert the gauge through the hole located on the bottom of the tank top and glue in place. The stops at the top of the gauge will keep it from going too far. Now glue the level (29) into the hole.

7. Glue the roof (12) onto the tank top (13).

8. Glue the water pipe (25) into the hole on the bottom of #9.

9. Glue the completed tank on top of the supports. Make sure that the water pipe goes between the top crossbar and the bracing rod on part #5.

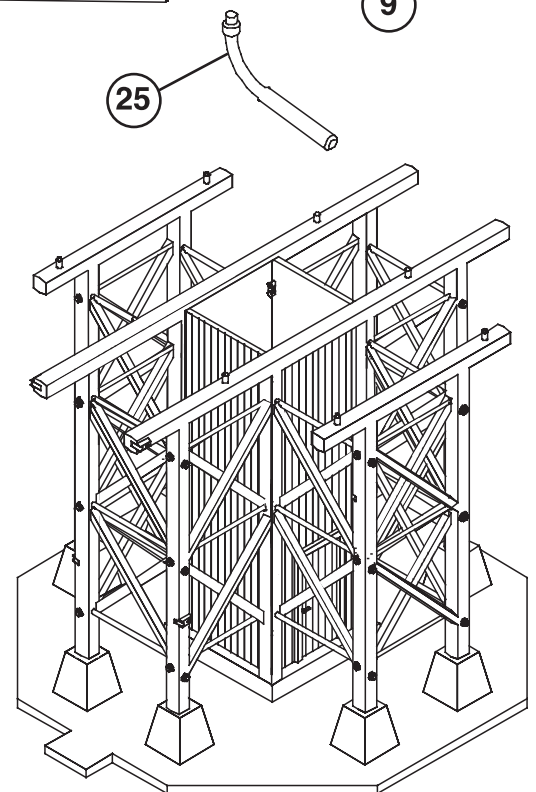

10. Glue the ladder (14) in place on the side of the structure. The top ladder bracing glues into the holes on the bottom of the tank top. The other two sets of braces attach to the timber support. Next glue the ladder hand rails (15, 16) on top of the ladder.

11. Glue the platform braces (19, 20) into the holes in the sides of part #5. Next glue the spout support (21) into the holes on the platform (18). Insert the top pegs of #21 into the holes in the bottom of the tank top and glue the platform onto the braces. Note: the water pipe will fit between the two horizontal cross braces near the bottom of part #21.

12. Glue the spout halves (23, 24) together. Snap the pegs of the spout hanger (26) into the holes at the top end of the spout. Glue the hanger to the spout support (21). Glue the pulleys (27) to the cross bar on the spout support.

13. Glue the finial (17) into the hole in the top of the roof.

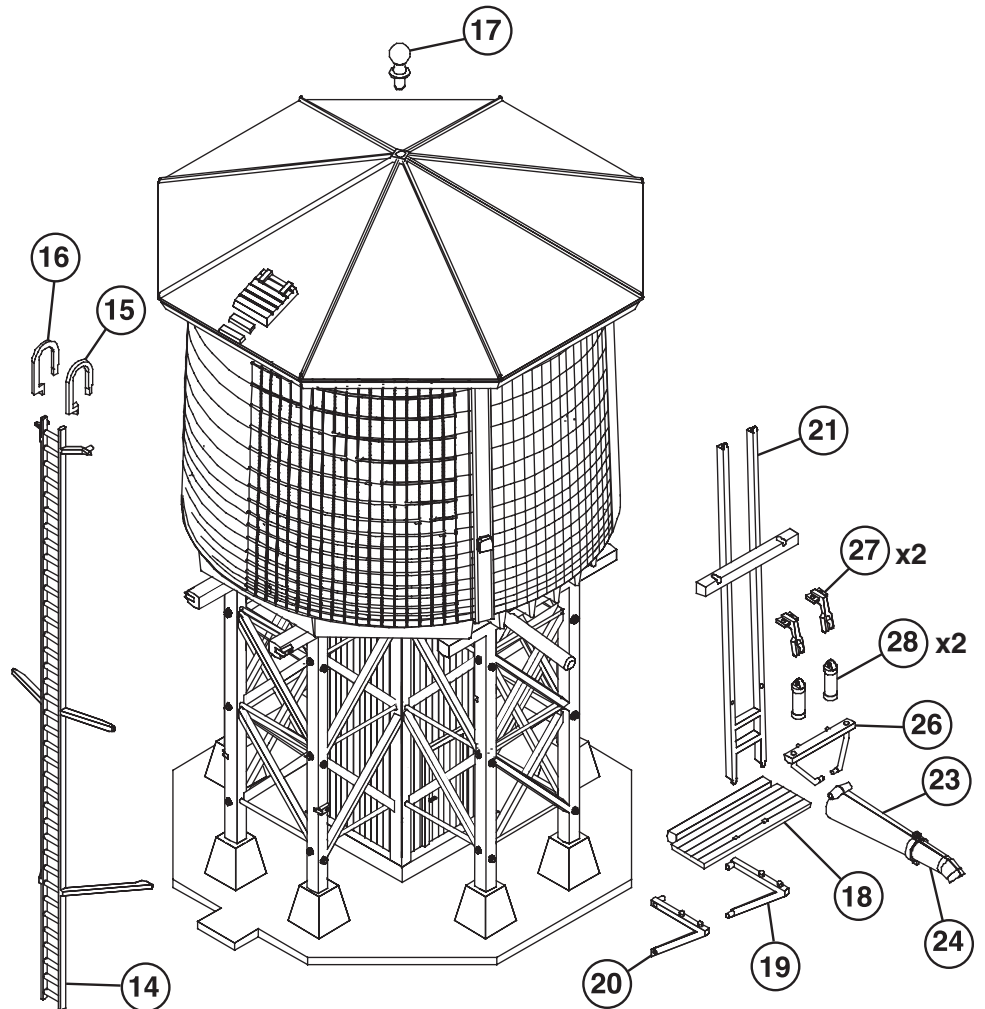

RIGGING INSTRUCTIONS

1. Cut two pieces from the provided thread, the first 4-1/8" long and the second 1-3/4".
2. Run the longer thread through the hole on the top of the spout. Then loop the ends over the pulleys. Insert the ends through the holes at the top of the counter weights (28) and tie off with a knot.
3. Run the shorter thread through the hole on the bottom of the spout and tie off with a knot.
4. You will be able to place the spout in the raised or lowered position.

