



HO Scale Structure Kit

FERROUS SHEAR

933-3630

Thanks for purchasing this Cornerstone Series® kit. All parts are styrene plastic so use appropriate paint and glue to complete your model. Please read the directions and study the drawings before starting assembly. The old sayings "everything old is new again" and "one man's trash is another's treasure" certainly applies to the salvage business. Today, the range of man-made materials being recycled into new products includes all kinds of metals, rubber, plastics, paper and more. Modern salvage operations not only collect these materials from local customers, they sort, shred, shape and ship them as raw materials to processing industries.

Subassembly #1-Shear Box: Glue the Shear Box Front (2) to Shear Box Back (4). Glue Shear Door (3) to Shear Box Front (2). Glue Upper Panel (5) to Shear Box Back flush with top edge of Part 4. Glue Shear Box Top (6) to the Shear Box Assembly. Glue Shear Cylinder (7) and Clamp Cylinder (9). Finally glue Shear Cylinder Head (8) and Clamp Cylinder Head (10) to top of Shear Cylinder and Clamp Cylinder.

Subassembly #2-Compactor: Glue Compactor Arm faces (20) to the Compactor Arms (19). Glue Bed Supports (13, 14) to Compactor Bed (15). Glue Compactor Box Front (17) into the slot on 15. Add part 18 (Both sides) to the Bed assembly. Lip on 18 rests on surface of 15. Ends must be flush against part 17. Glue Compactor Arm assemblies (19, 20) to part 18 - make sure they are vertical. Also note that the 'hinge' on 19 is glued to the upper inside face of 18.

Subassembly #3-Pusher: Glue Pusher Housing (21) to Pusher Cylinder (22)

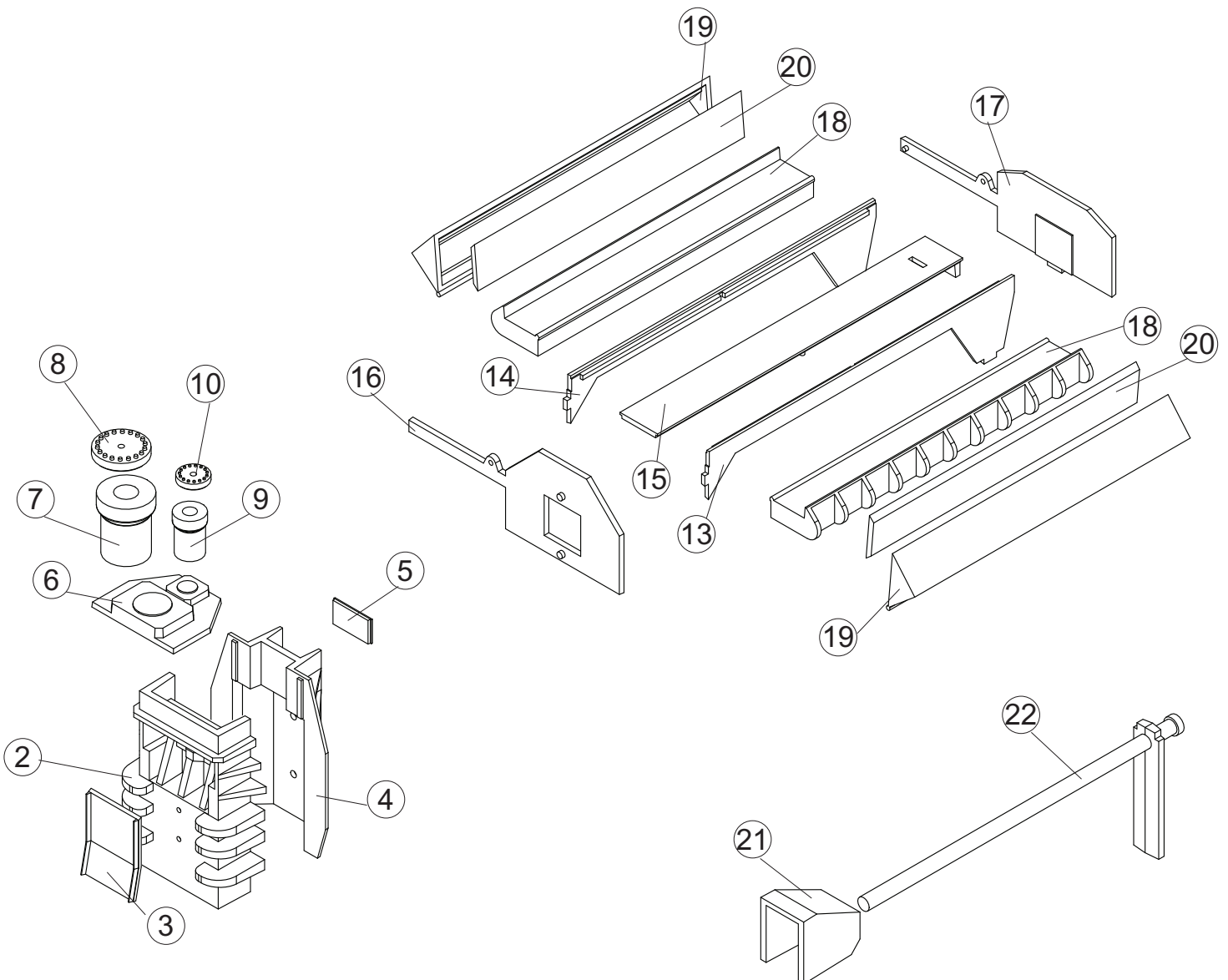

Sub-Assembly 4: Glue Hopper Front (23) Hopper Base (24) and Hopper Back (25) together.

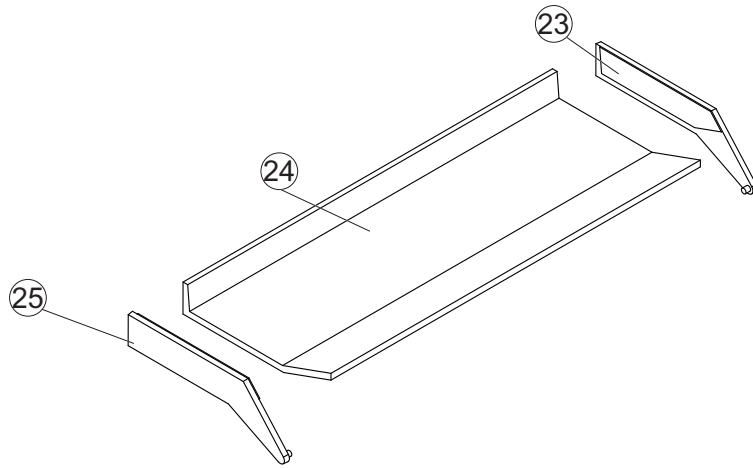

1. Glue Shear Box (Subassembly 1) to Compactor (Subassembly 2). Glue this unit to Base (1). Add Pusher (Subassembly 3) as shown.
2. Insert Hopper Lift Cylinder (27) to Lift Cylinder base (28) - but do not glue. Carefully glue this assembly to Base (1) so that Cylinder (27) is free to move.
3. Glue Hopper Support (26) to Base (1), and to the locating nibs on parts 16 and 17.
4. Snap Hopper (Subassembly 4) onto Compactor. Glue the end of Cylinder (27) into the hole on underside of Part 24.
5. Finally, Glue Shear Cylinder Pipe (11) and Clamp Cylinder Pipe (12) to the Base and Subassembly 1.

