



HO Scale Structure Kit

SCRAP YARD CONVEYOR

#933-3645

Thanks for purchasing this Cornerstone Series® kit. All parts are styrene plastic so use appropriate paint and glue to complete your model. Please read the directions and study the drawings before starting assembly. The old sayings “everything old is new again” and “one man’s trash is another’s treasure” certainly applies to the salvage business. Today, the range of man-made materials being recycled into new products includes all kinds of metals, rubber, plastics, paper and more. Modern salvage operations not only collect these materials from local customers, they sort, shred, shape and ship them as raw materials to processing industries.

1. Glue Conveyor Left Side (4), Conveyor Belt (6) and Conveyor Right Side (5) together. Glue Conveyor Motor and Drive Cover (7) to Conveyor Assembly.
2. Glue Conveyor Boom Foot Brackets (3) to Conveyor Assembly. Glue Turntable (2) to Conveyor Boom Foot Brackets (3).
3. Glue Conveyor Assembly and Turntable (2) and Turntable Retainer (14) together through the hole in the Base (1). Note: Be careful not to use excessive glue. The Boom Turntable should swivel freely in the hole in the Base.
4. Glue Frame Left Leg (9), Frame Head (10) and Frame Right Leg (8) together. Then glue to Base (1).
5. Glue Table Support Left (13) and Table Support Right (12) to Base (1). Glue Shaker Table (11) to top of Table Supports.

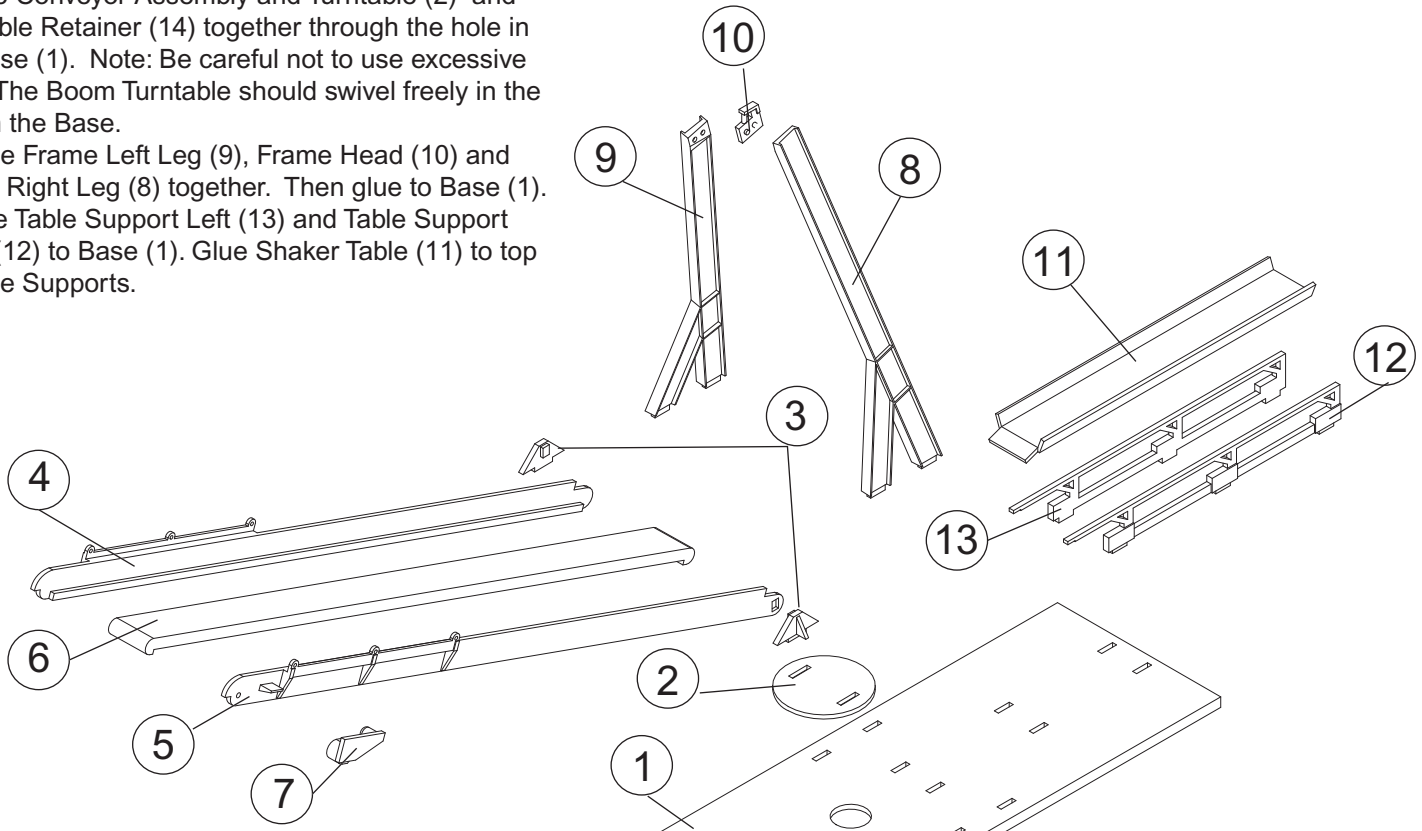

6. Glue the Frame Assembly and the Shaker Table Assembly to the base. There are Locator Holes in Base for easy assembly.

RIGGING INTRUCTIONS

1. Cut the enclosed thread into three pieces; one about 15-3/4" (40cm), and two about 11-3/4" (30cm) long.
 2. Begin by tying one end of an 11-3/4" piece to the eyelet hole at the lower end of the conveyor. Thread through the Frame Head, pull taut, and tie loosely in place on the eyelet on the opposite side.
 3. Install the second 11-3/4" piece in the middle eyelets: thread and secure as in Step 1.
 4. Install the 15-3/4" piece in the top eyelets: thread and secure as in Step 1.
- Adjust the tension of the cables evenly. Secure each knot with a tiny drop of CA adhesive (not included).

