



HO Structure Kit FIRE DEPT. HEADQUARTERS 933-3765

Thanks for purchasing this Cornerstone kit. All parts are styrene plastic, so use compatible glue and paint to assemble and finish your model. Please read all directions and study the drawings before starting construction.

The 1920s were a time of great change in big city fire departments all across the US. With the shift from horses to horsepower nearly complete, many were also building new shop and training facilities and replacing obsolete stations. While the onset of the Depression brought a halt to many plans, later government programs put people back to work in the construction trades building a new generation of fire stations. For many larger communities, priority was given to a central headquarters building, usually located in or close to the high-value downtown business, commercial and office districts. Here, one would find the department's best equipment, including high-volume pumpers and aerial ladders, specialized truck companies for rescue and salvage work, as well as the chief's and assistant chief's department automobiles. The Captain's office, along with the alarm room (housing equipment connected to the city's call box alarm system) and storage would also be found on the lower level. The upstairs included modern dormitories a full kitchen, training and recreation rooms, and offices for the chief and his immediate staff. Typical of such projects in those financially tough times, they projected strong, modern lines with a bare minimum of trim. Many would serve their communities for decades with little modification, including the Des Moines, Iowa, Fire Department Headquarters, used from 1938 to 2012, which is the basis for this model.

As built, this facility was part of a larger complex that included a Fire Department Drill Tower (#933-3766) and the Fire Department Repair Shop (#933-3767). Appropriate SceneMaster vehicles (manufacturer #949), figures and other accessories to finish your scene can be found at participating hobby shops, online at walthers.com and in the current HO Model Railroad Reference Book.

1) Glue columns (2) to the inner front wall (1), then glue column caps (3) in place. Glue trim (6, 7) and brick panels (17, 18, 19, 20 & 21) to the outside face of part 1. Make sure the narrow edges of the crossbars (muntins) on all windows (37) face outside and glue to the inside face of part 1. If desired, some of the large overhead doors (39) can be left off to model an open bay; a partially open door can be modeled by cutting one or two sections off a door and gluing it in place to the upper part of a doorway, or the complete door can be glued in place.

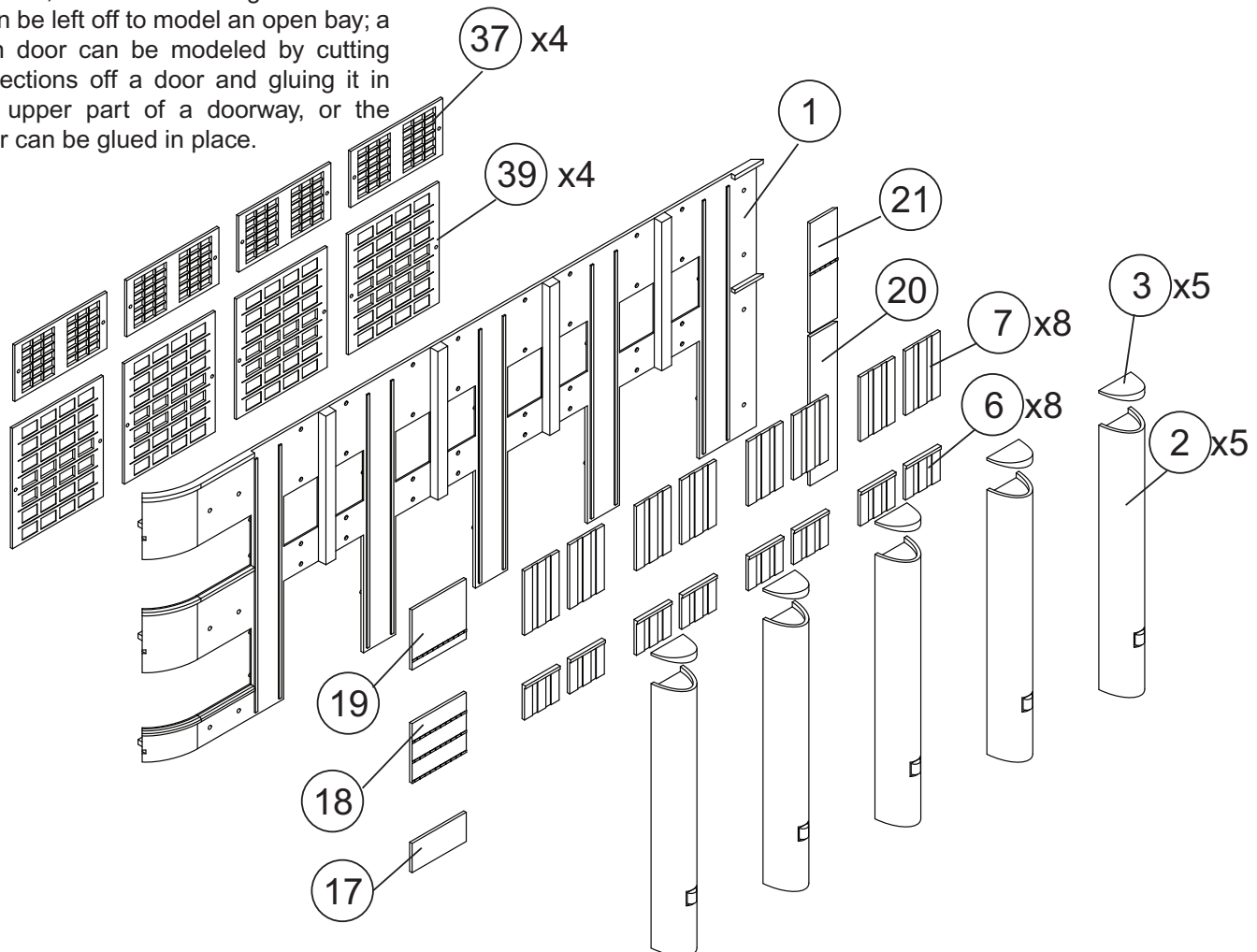

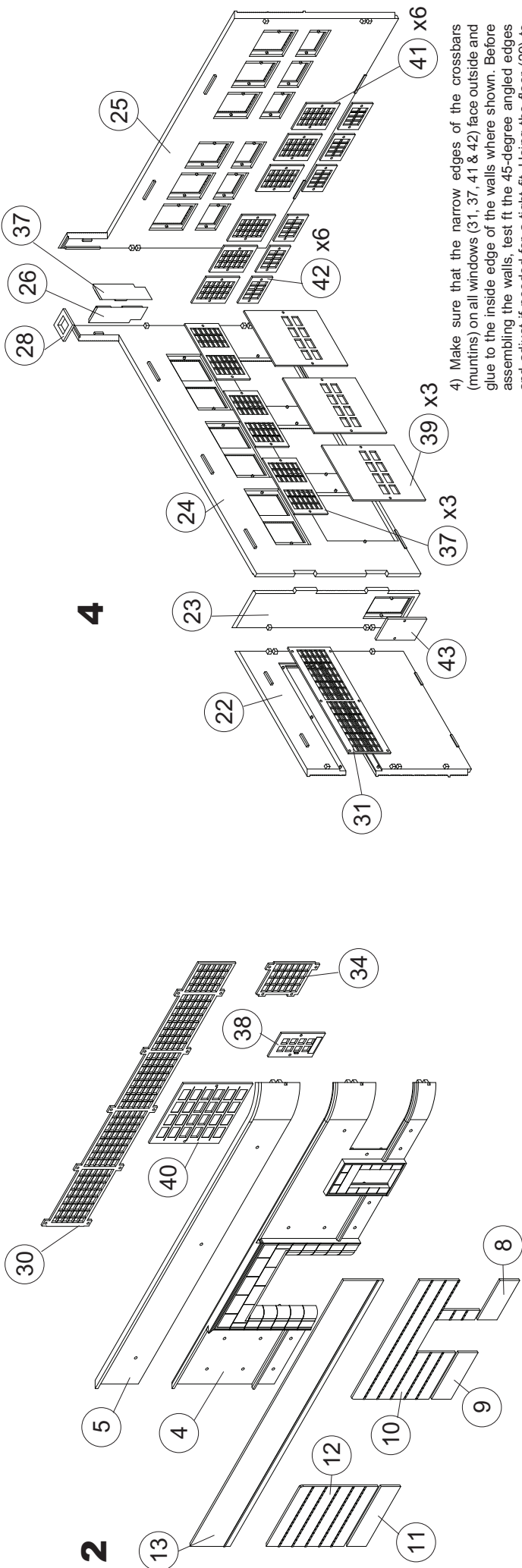

2) Glue brick panels (8, 9, 10, 11 & 12) to wall (4). Make sure the narrow edges of the crossbars (muntins) on all windows face outside and glue window (34) to wall as shown; glue long window band (30) to the top inside edge of part 4 and the bottom inside edge of the upper wall (5). Glue personnel door (38) to inside of wall (4); overhead door (40) can be left off, modified as in step 1 or glued in place as desired. Glue brick panel (13) to the outer face of part 5.

4) Make sure that the narrow edges of the crossbars (muntins) on all windows (31, 37, 41 & 42) face outside and glue to the inside edge of the walls where shown. Before assembling the walls, test fit the 45-degree angled edges and adjust if needed for a tight fit. Using the floor (29) to keep the assembly square, glue walls (22, 23, 24 & 25) to the floor and together at the inside corners. Glue chimney parts (26, 27) to walls (24, 25) as shown, and glue chimney cap (28) in place.

Cut glazing from the clear sheet slightly larger than all windows and doors, and attach to the rear surface of each with white glue.

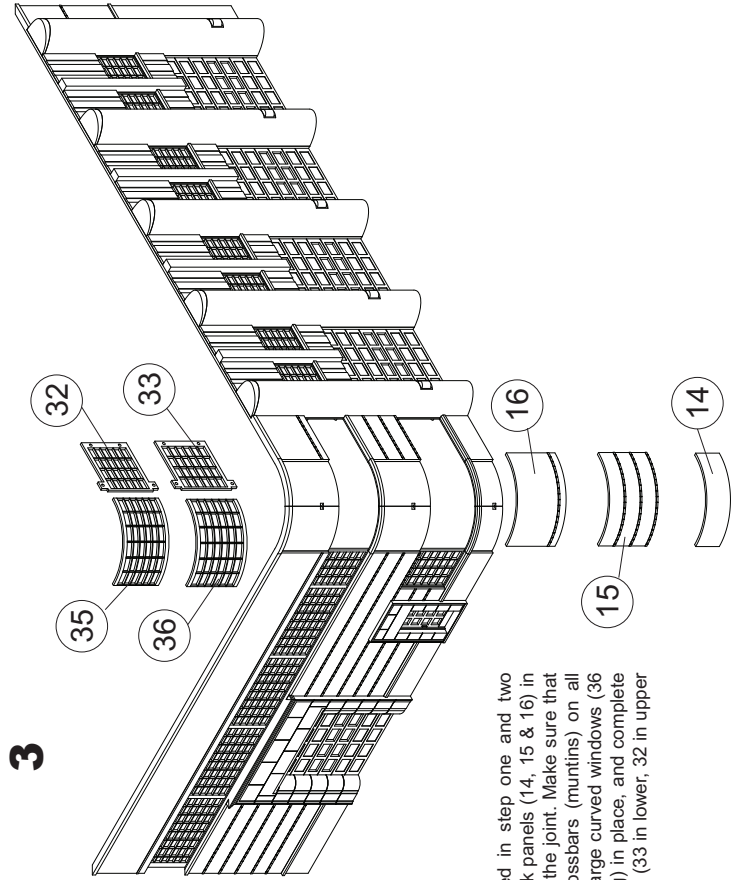

3) Glue the walls assembled in step one and two together as shown. Glue brick panels (14, 15 & 16) in place to cover and reinforce the joint. Make sure that the narrow edges of the crossbars (muntins) on all windows face outside; glue large curved windows (36 in lower, 35 in upper opening) in place, and complete assembly with small windows (33 in lower, 32 in upper opening) as shown.

5) Glue the short sidewalk/ramp (46) and the long sidewalk/ramp (29) to the floor (29).

6) The roof may be glued in place if desired, or set in place so it can be removed to add interior details (sold separately). Glue vent bases (44) in openings, then glue vent tops (45) to bases. When dry, the vents may carefully be used as handles to assist in fitting the roof in position. Insert the roof into the opening, working it under the chimney and into position on the locating ridges. Make sure the fire escape platform (50) is positioned with the thinner side of the ladder opening towards the wall, and glue in place on wall (24). Glue railings (51, 52 & 53) to platform (50). Make sure the standoff pins are at the very bottom of the ladder (48) and glue in the openings in wall (24). If gluing your roof in place, glue the ladder top railing pieces (49) to the outside edges of the ladder (48): for a removable roof, do not use these parts.

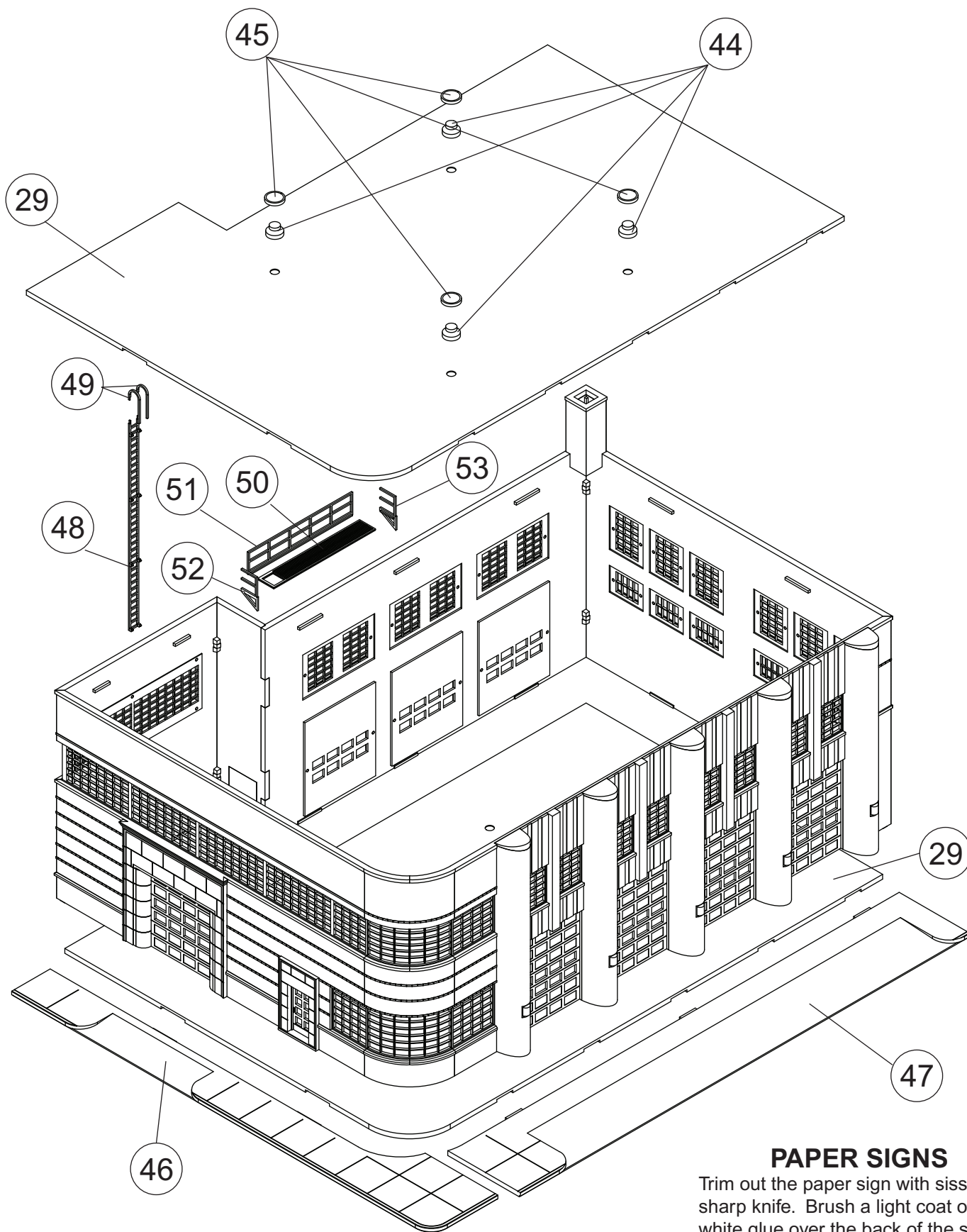

PAPER SIGNS

Trim out the paper sign with scissors or sharp knife. Brush a light coat of white glue over the back of the sign. Place into position and press permanently into place with your fingers.