



HO Structure Kit FIRE DEPT. DRILL TOWER 933-3766

Thanks for purchasing this Cornerstone kit. All parts are styrene plastic, so use compatible glue and paint to assemble and finish your model. Please read these instructions and study the drawings before starting construction.

Fire has been mankind's best friend and worst enemy for millions of years, becoming a major threat as we began living in cities. The ancient Egyptians were probably the first to develop methods for combating fires, which were later revived in the Roman Empire. For centuries, the chief skill a firefighter needed was strength and endurance to pass buckets, or handle the axe and pike (all still used in modern form today). The arrival of hand-pumpers still required strong backs, but the complexity of the machines also led to the first regular drills and training programs. Little if any formal training was required of firefighters for the next century, but that changed in major cities by the late 1800s, when programs with classroom and laboratory work, as well as special training towers were started. Originally built to teach the proper use of ladders, ropes and hoses, training towers have continued to evolve and fill an even more important role today. Modern versions include provisions for instruction in all types of search and rescue techniques, live fire exercises to simulate actual conditions as closely as possible, physical fitness training and more.

Your new model is typical of training towers in use for decades, and is based on a tower built as part of a larger complex in Des Moines, Iowa, that included the Fire Department Headquarters (#933-3765) and the Fire Department Repair Shop (#933-3767). Appropriate SceneMaster vehicles (manufacturer #949), figures and other accessories to finish your scene can be found at participating hobby shops, online at waltherscornerstone.com and in the current HO Model Railroad Reference Book.

1) Test fit walls (2, 3, 4 & 5) at the 45-degree angle; smooth if needed for a tight fit, but do not remove the locating pegs. Glue walls (2, 5) together and to base (1).

2) Note the 45-degree front and side edges on floor (6); use the slots as a guide and glue to walls (2, 5). Glue two floors (7) in place on walls (2, 5).

3) Glue window (53) to the back of wall (4). Align and seat floors (6, 7) with slots in wall (4). Glue wall (4) to wall (5), to floors (6, 7) and base (1) – wall (3) and window (54) will be installed later.

4) Push post (10) through openings in floors (6, 7) and into recess on base (1) and glue in place. Position roof (9) so the recess on the bottom aligns with post (10). Be sure the roof is seated properly and glue in place.

5) Carefully remove net tower parts from the sprues to avoid damaging the locating tabs on the beveled edges. Glue net tower sides (11, 12, 13 & 14) together, to the base (1) and roof (9). Glue top (15) to tower.

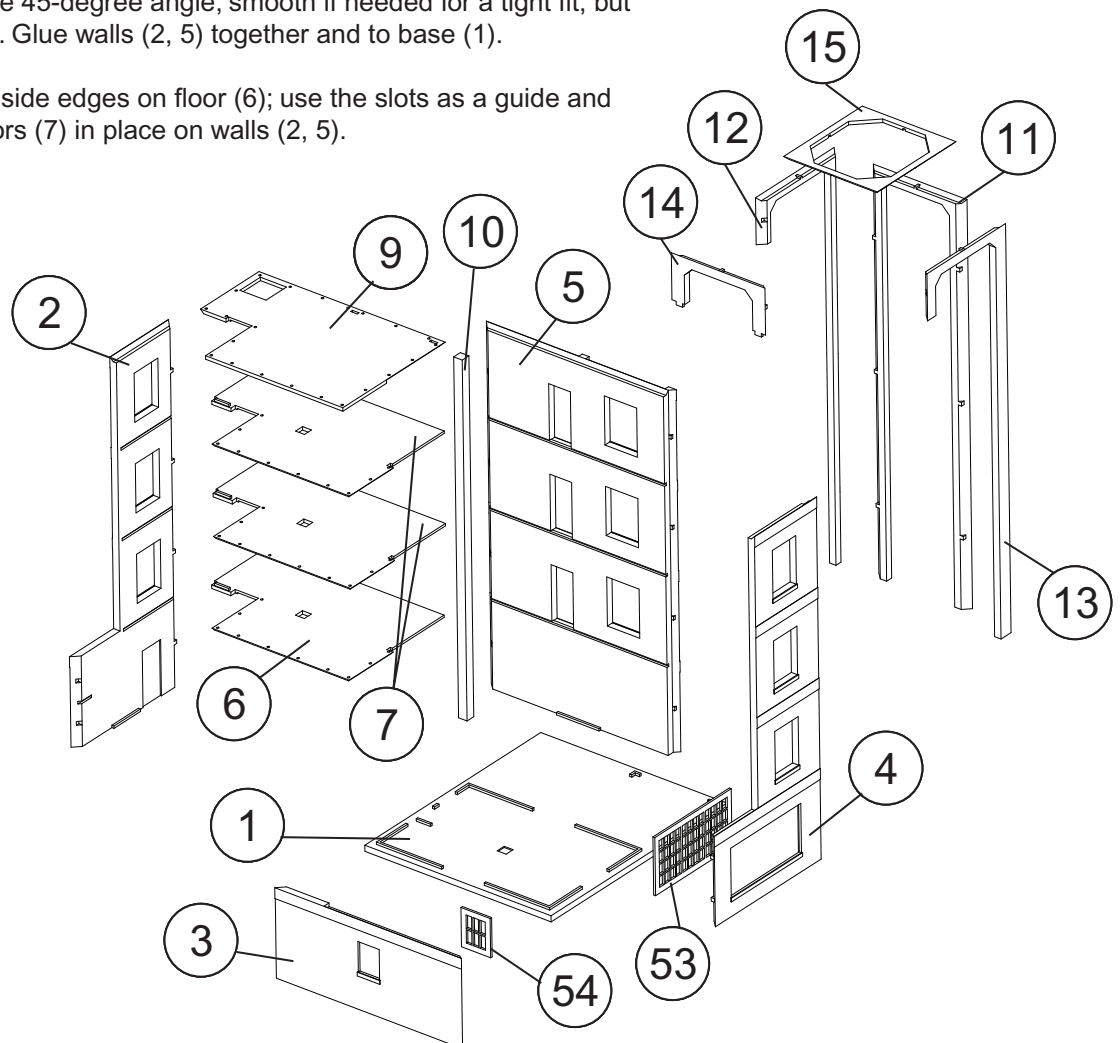

6) Test fit platform (39) in slots on walls (2, 3); if fit is tight, thin platform edges carefully with hobby knife or sandpaper. For best assembly and appearance, make sure the sides of all stairs (37; 8x) are flat; carefully file or sand if needed. Glue a railing (41) to the side of stair (37); fit the slot in the bottom of the stair over the ridge on the base (1), fit the platform into the slot on wall 2, and glue stair to base.

7) Glue left and right railings (43, 55) to stairs 37. Note that that locating notch in #37 is the "downstairs" end. Glue this assembly between platform (39) and floor (6).

8) Glue window (54) to wall (3); glue completed assembly to walls (2, 4), base (1) and front edge of floor (6).

9) Glue railings (40, 41) and platform (38) to stairs 37. Glue railings (42, 43) to stairs 37; glue this assembly to platform (38), and finish with railing (44). When dry glue lower stair on floor 6, and top stair in to recess on the underside of floor #7. Repeat step 9 to complete two sets of stairways connecting upper floors (7) and roof (9) as shown.

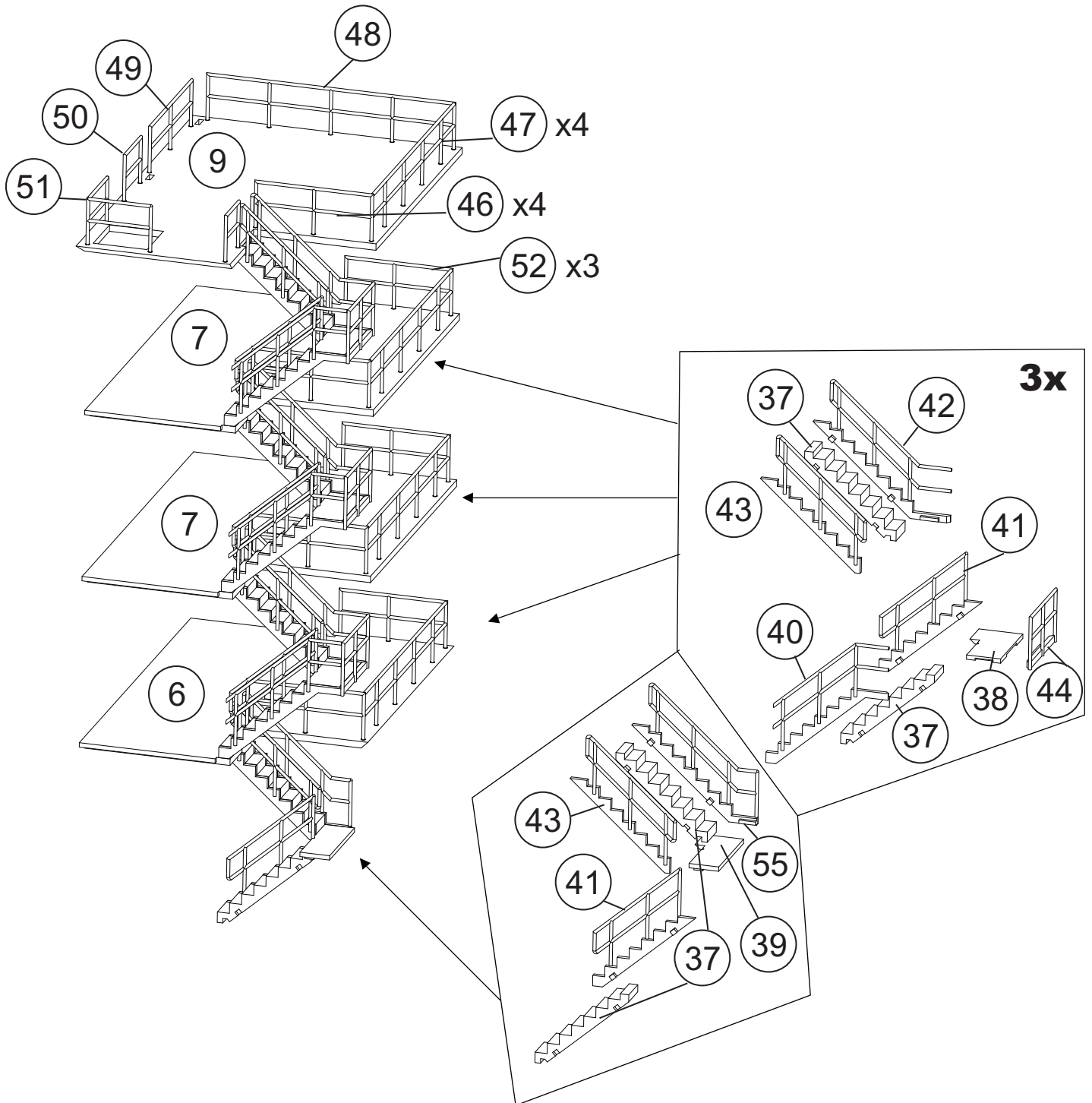

10) Glue left floor railings (46), right railings (52) and end railings (47) on floors (6, 7) and roof (9). Add railings (48, 49, 50 & 51) to roof as shown.

11) Glue bracket/railing (20) and bracket (21) to platform (16); glue completed assembly below first doorway opening on wall (5) as shown.

12) Glue bracket/railing (23) and bracket (24) to platform (17); glue completed assembly to lower intermediate locating ridge on wall (5) as shown. Repeat these steps but glue second assembly to upper intermediate locating ridge on wall (5).

13) Glue bracket/railing (26) and bracket (27) to platform (18); glue completed assembly under third floor doorway on wall (5) as shown.

14) Glue bracket/railing (26) bracket (27) to platform (19) then glue railing (31) and bracket/railing (32) to platform. Glue completed assembly under fourth floor door opening on wall (5) as shown.

15) Glue railing (22) to stairs (30); align upper vertical edge of railing (22) with top of stair (30), glue completed assembly between platforms 16 & 17.

16) Align the upper vertical edge of railing (28) with top of stair (33) and glue in place. Glue this assembly between platforms 17 (lower) & 18. Glue outside railing (25) to stair (33) and to platforms 17 & 18.

17) Align the upper vertical edge of railing (28) with top of stair (33) and glue in place. Glue this assembly between platforms 17 (upper) & 19. Glue outside railing (25) to stair (33) and to platforms 17 & 19.

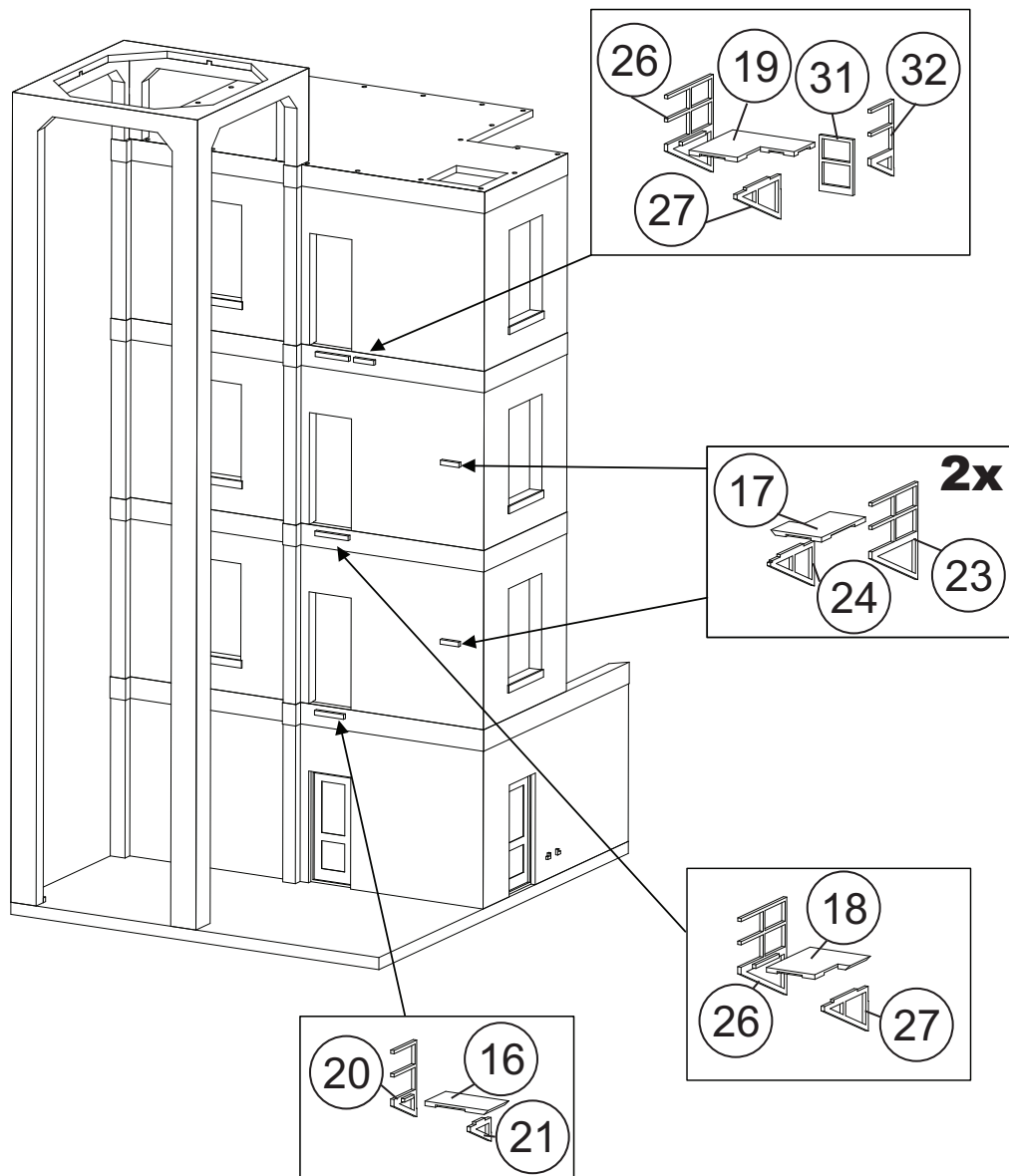

18) Align the upper vertical edge of railing (28) with top of stair (33) and glue in place. Glue this assembly between platforms 18 & upper 17; the lower end of the railing (28) overlaps the side of the platform. Glue outside railing (25) to stair (33) and to platforms 18 & upper 17.

19) Carefully remove fire escape ladder (34) from the sprue, paying special attention to the thin ends. Attach ladder top railings (35) to ladder 34, overlapping the half-thickness sections of both parts. Glue completed assembly to wall (5) between platform (19) and roof (9). Attach ladder top railings (35) to ladder 36, overlapping the half-thickness sections of both parts. Use small raised lines near the bottom edge of wall 2 to locate the lower stand-off pins on ladder 36, and glue assembly to wall 2.

