



# HO Scale Structure Kit

## RIVOLI THEATER

# 933-3771

Thanks for purchasing this Cornerstone Series® kit. Please read all instructions and study the drawings before starting. All parts are styrene plastic, so use compatible glue. If you wish to decorate your model, use paints for plastic models. With appropriate details and signs, your finished model fits almost any era.

Whether you were hot on the trail of a notorious stage robber, seeing the news of the world, plunging through the trackless jungles, or falling in love for real or just in your imagination, there was no better place to spend a few relaxing hours than at the local movie theater. Americans became totally immersed in both the movies and the stars that made them in the 1920s, and by the end of the decade, the local movie house had become a fixture of main streets large and small.

Some of these originated as vaudeville or local opera houses, where the stage was still used for live entertainment, and the screen simply lowered to show movies. Others were built new from the ground up, and no expense was spared to make the front of the building unique and attractive, especially after dark, when the marquee would blaze to life.

Since the movies always drew a crowd, it was not unusual to find lunch counters, candy stores, ice cream parlors and similar businesses next door, serving patrons going to and coming from the show.

By the 1960s, many of these once grand movies palaces were falling on hard times, finding themselves in less desirable parts of town, and considered too small to be profitable. Many fell under the wrecking ball, and a few were repurposed, often as storefront churches. As downtown areas have been revitalized in recent years, many older theaters have also had some of their former glory restored and are now used by community theater groups for live shows, or as a venue for presenting classic movies in their original surroundings.

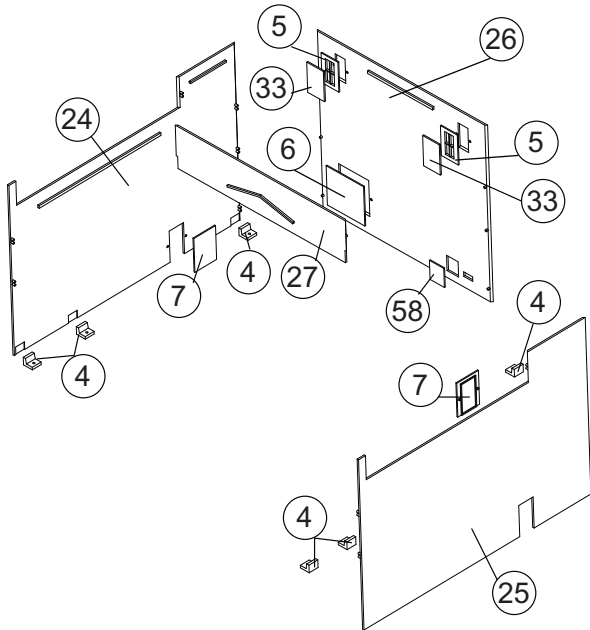

1) Begin assembly by gluing parts (4, 5, 6, 7, 58) to the back of walls (24, 25, 26, 27) as illustrated. Add clear glass (33) to the window backs, then glue the wall sections together.

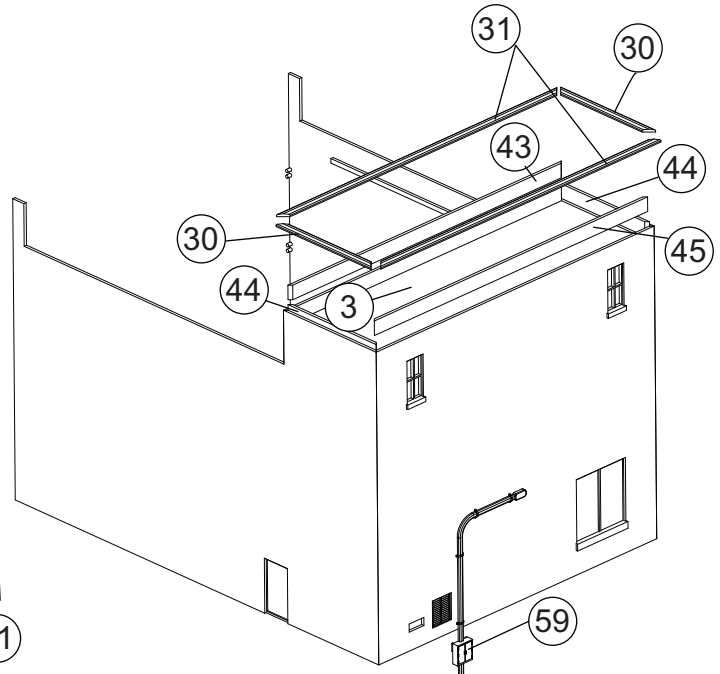

2) Install Roof (3) next, by dropping it into position. Glue Brick trim pieces 43, 44 and 45 to the back of walls 24, 25, 26 and 27 to secure the roof. Add Cap Tiles (30, 31) to the wall tops, and the Electrical Cabinet (59) to the back wall.

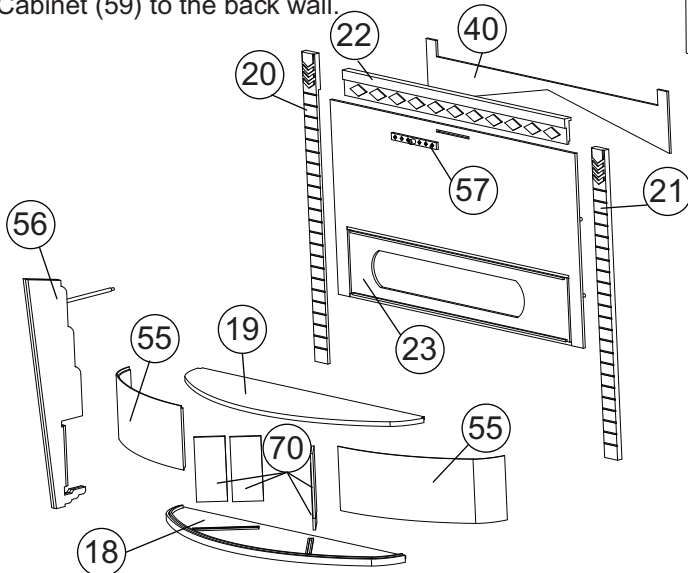

3) Glue Decorative Trim parts (20, 21, 22), and Sign Brace Flange (57) to Front Wall 23, and part 40 to the back side as shown. Carefully align and position spacers (70), and Signboard Halves (55) to the Lower section (18) of the Marquee and glue together. Before this assembly dries - add the Upper Section (19), and make any final adjustments. When dry - add Sign (56) by installing the bottom portion first, then swinging the upper portion into position. Add the completed marquee to the front wall.

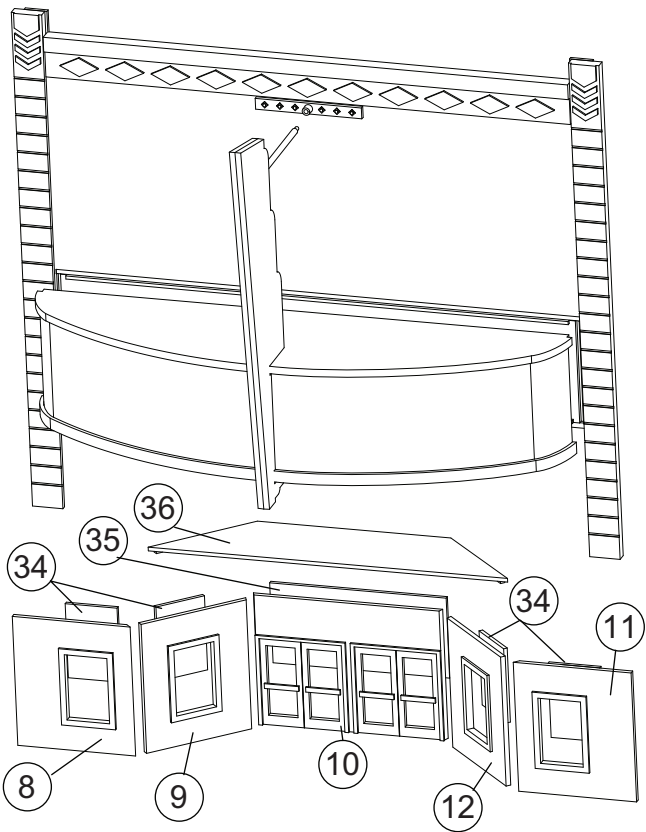

4) Use Roof Section (36) as a guide for assembling the Main Entrance parts (9, 10, 12) at the proper angle. Add Display Window panels (8, 11) to both sides next. When dry, glue the clear glass sections (34, 35) to the backsides of the walls, then add this assembly to the backside of the front wall.

5) Apply Ticket Window glass parts (37 and 38) to the backsides of Ticket Booth walls (13, 14, 15). Glue these pieces together (13, 14, 15, 16, 17) and then to the Base (1). View Block (28) is added next.

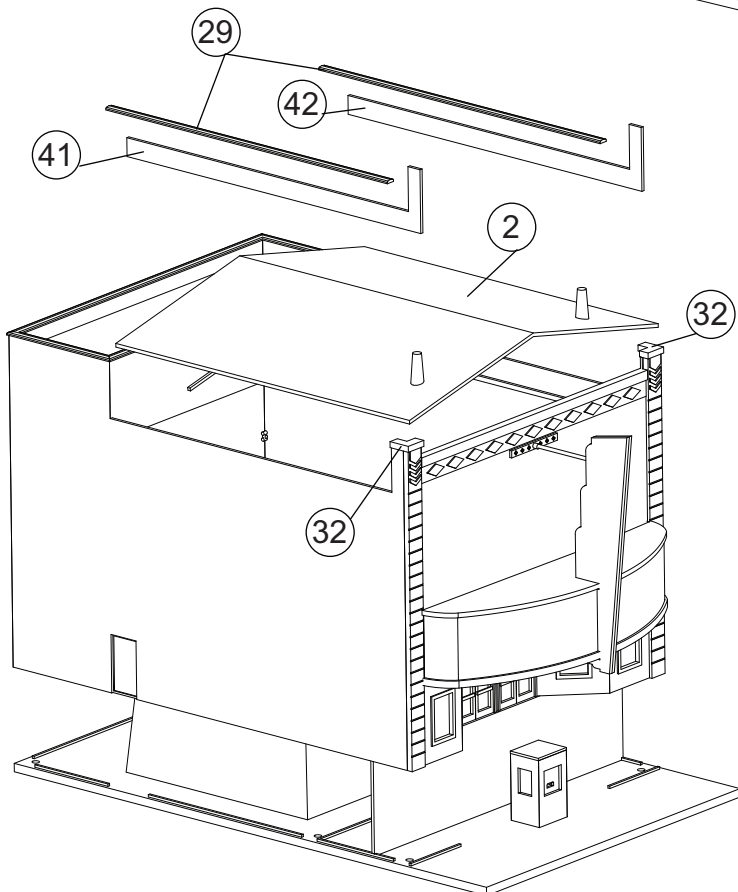
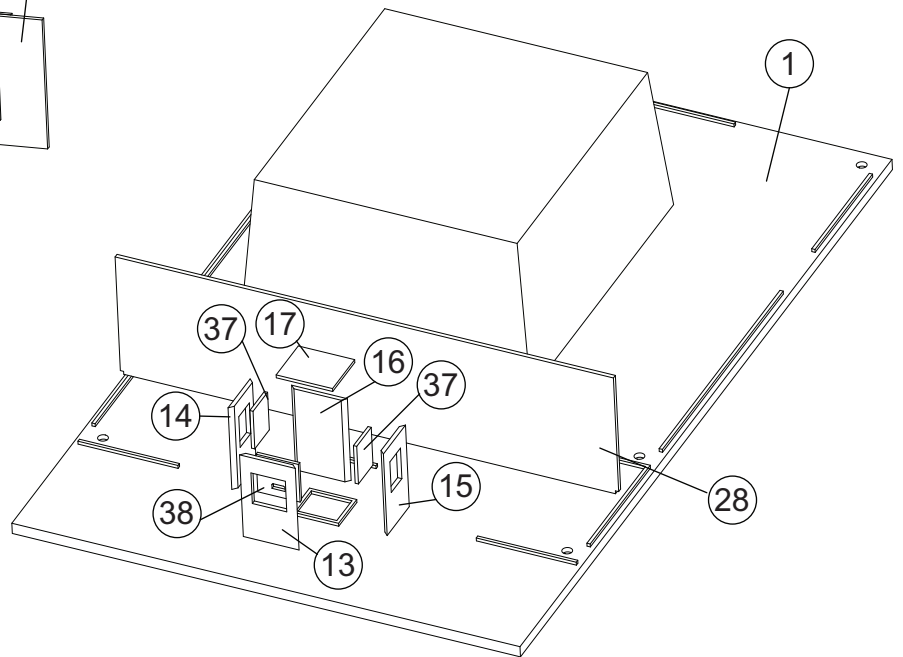

6) Glue the Front Wall to the assembly from Step 2. Place the Roof (2) in position, then add Brick Trim parts (41, 42) to the side walls to secure the roof. Add Cap Tiles (29), and Concrete Trim (32) to the wall tops as shown. Do not glue the model to the base yet - the graphics are easier to apply at this stage. Trim out the images with a sharp knife. The movie posters are best taped behind the glass with a quality tape. The Marquee art is best applied with a water based adhesive brushed thinly and evenly on the intended part. Set the trimmed art piece into position lightly. Make any adjustments, then press the graphic into final position. When finished, the model can then be glued to the base.