



N Scale Structure Kit 933-3816

CINDER CONVEYOR & ASH PIT

Thanks for purchasing this Cornerstone Series® kit. Please study the instructions and drawings before starting. All parts are styrene, so use compatible glue and paint to assemble your model.

When railroads ran on coal, engine fires had to be cleaned daily. In the intense heat of the firebox, impurities in coal such as sulfur, iron, ash and dirt were released. These would partially burn and produce cinders. Others would mix with oxygen as new compounds, then fuse with ash and dirt to produce a hard lump called a “clinker.” As the fuel burned, these waste products dropped through the grates into the ashpan below.

If too much of this accumulated, the grates at the bottom of the firebox could become plugged. Since most of the air consumed by the fire came through them, they had to be kept clear. Cleaning the ashpan became part of the regular routine for firemen at each service stop. Clean-outs on the side of the ashpan were opened so the hot ash could be raked out and dumped in a small open spot below the tracks. Ranging from a few inches to a few feet deep and several feet long, these dumping spots came to be known as “ash pits” (“clinker pit” and “cinder pit” were also common nicknames).

Enormous amounts of cinders were generated depending on the number of locos serviced and the quality and type of coal used; a large terminal servicing 100 engines could accumulate 120 to 125 cubic-yards of cinders every day! Older, smaller ash pits couldn't begin to handle such volume. And railroads soon found that cinders could be used as ballast and fill. Larger pits were needed, along with ways to remove the cinders. And while designs varied to meet local conditions, all pits shared some basic features.

Once cool, cinders could be removed. Most pits were open on at least one side, so cinders could be shoveled out by hand and into a waiting gondola on a parallel track. In later years, this track was often sloped downward so the top of the gondola was about the same height as the pit, making it easier for workers to load the cars. Hand

shoveling just wasn't practical for large, busy facilities. And since railroads were always looking to cut costs, all types of cranes and other mechanical devices were tried from the 1890s on.

By the 1920s, many of the early pits and their homemade lifting equipment were wearing out. Years of exposure to blistering heat, sudden cooling and sulfuric acid (created when sulfur in the cinders mixed with water) all took their toll. More trains and faster schedules put more demand on the pit, creating bottlenecks in terminals. And large, new engines not only produced more ash, but were also much heavier and strained the steel supports.

At this time, commercial suppliers began selling mechanical cinder handling plants. These compact facilities required less space and could handle more material at lower cost. In place of the open and dangerous pit, a small tunnel was built crossways beneath the track (this could be extended under several tracks if desired). Large steel or iron hoppers between the rails received several cubic-feet of hot ash then funneled it into a skiphoid bucket below. The most visible part was the superstructure alongside, consisting of a steel tower with an enclosed hoist house on top. Riding small, flanged wheels on rails, the loaded bucket was pulled out of the pit and up the tower. Near the top, steel pins tipped it to one side, dumping the load into a waiting gondola below. With one of these facilities, a single operator could now do all of the work, and the need for a depressed loading pit for gondolas was eliminated. A water supply line was still provided, as ash had to be cooled to prevent damaging the pit, as well as the wood or steel gondolas used for cinder loading.

Most engines had their fires cleaned at terminals as part of the inspection and servicing procedure at the end of each run. Each road had its own preference for when the fire was cleaned, which determined the “ideal” location for the pit along the inbound service track. If capacity became an issue, two or more could easily be built next to each other. Cinder conveyors weren't limited to engine terminals; they

could also be found along the mainline on some roads, typically near water tanks and coaling facilities. The capacity of the ashpan limited how far an engine could run, and as longer trips became common, it was often necessary to clean the ashpan enroute. Railroads also found that providing these outlying facilities reduced congestion and increased efficiency at major terminals.

The coming of diesels signaled the end for cinder conveyors. Many remained for a brief period after a road dieselized, but their small size and accessible location made them easy to scrap, while safety issues led to the pits being filled.

ON YOUR LAYOUT

This small structure generates a lot of action at any engine terminal. The model is based on a Fairbanks-Morse prototype introduced in the late 1920s, and many were used well into the 1950s. Once installed, it can add a lot of interest to operations. You can easily simulate the inspection and service process, allowing extra time to clean the fire. Working the conveyor can also be a job for your yard crew as empty gondolas are spotted for loading and filled cars moved into outbound trains.

As part of a large engine terminal, your new kit is right at home alongside the Modern Roundhouse (#933-3260), which can be enlarged with the Add-On Stalls kit (#933-3261), Machine Shop (#933-3264), Modern Coaling Tower (#933-3262), 130' Turntable (#933-2613), Sanding Tower (#933-3813) and Steel Water Tank (#933-2601).

For more ideas to detail your scene, ask your dealer, visit walthers.com or see the latest Walther's N&Z Scale Model Railroad Reference Book.

1. Glue the two sides (4,5) and the braces (6,7,8) together as shown. Note: Look at closeup below to line up parts correctly.

Glue the braces and sides together by aligning the the bottoms of the inner tabs as shown. If this is not done, brace #'s 6 and 7 will not sit flush on the base (1).

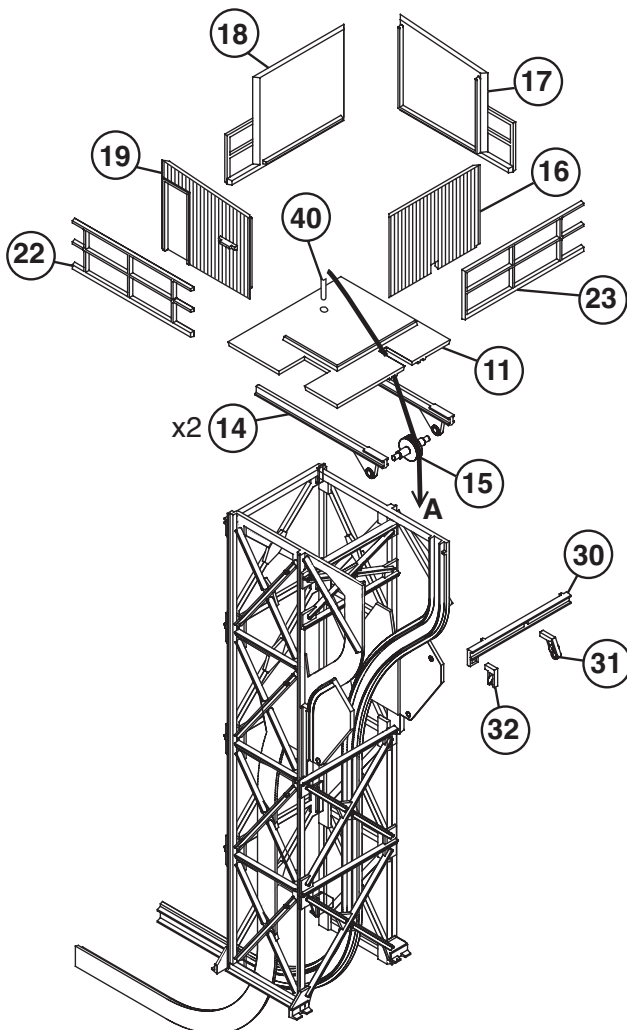
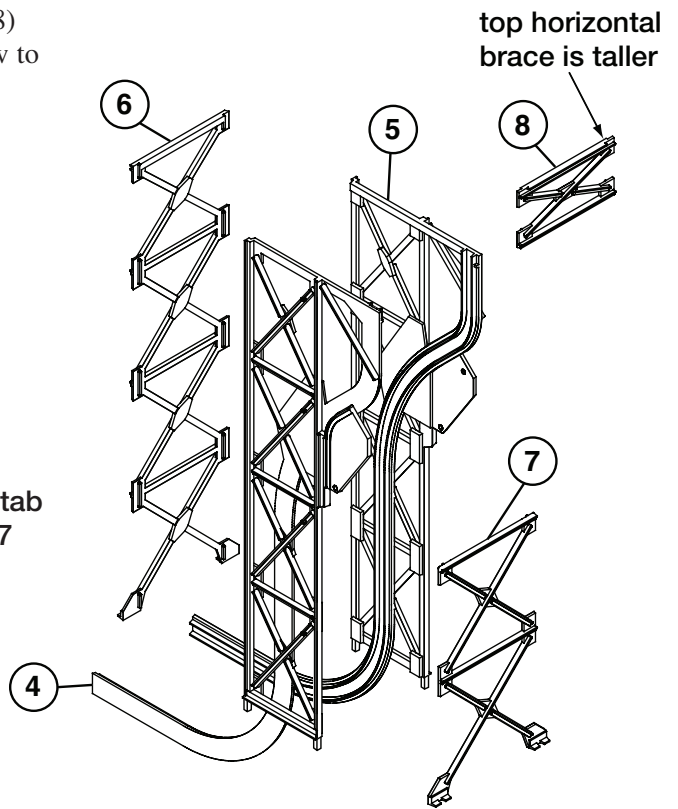
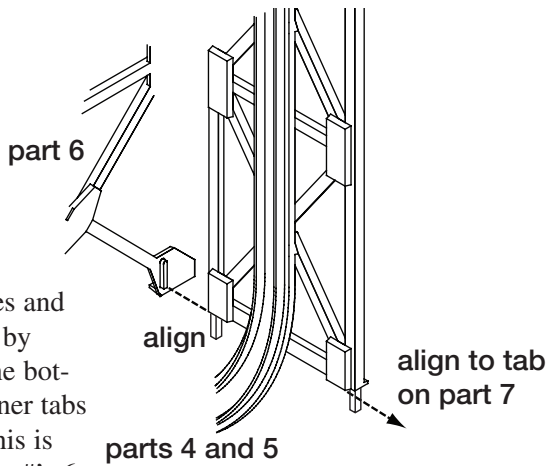

2. Glue the post (40) to the floor (11). Note: See cinder car rigging instructions if you wish to add the cinder car cable before continuing.

3. Glue the headhouse walls (16,17,18,19) to the floor (11). Then glue on the railings (22,23).

4. Place the head sheave (15) between the beams (14) and then glue them in the slots underneath the floor (11).

5. Glue the headhouse in place on top of the sides. Next glue the top pulley beam (30) to the ends of the beams and the sides. Use the notches on the back of the pulley beam to line up with the sides and the beams. Glue the top (31) and side (32) pulleys to the pulley beam as illustrated.

CINDER CAR RIGGING (step 2)

First, cut thread in half and reserve one piece for later. Glue one end of thread to the top of the post (40). Run thread down through the slot in the floor (11), over the head sheave (15). Depending on the position of the cinder car, cut or wind the thread to the length desired and attach to the cinder car (see step 8). Note: "A" denotes the same thread in both illustrations.

6. Glue the cinder car sides (33,34) to the car bottom (35). Place the wheel beams (36,37) in the holes in the sides. Glue the yoke (39) into the holes on the inside of both of the wheel beams.

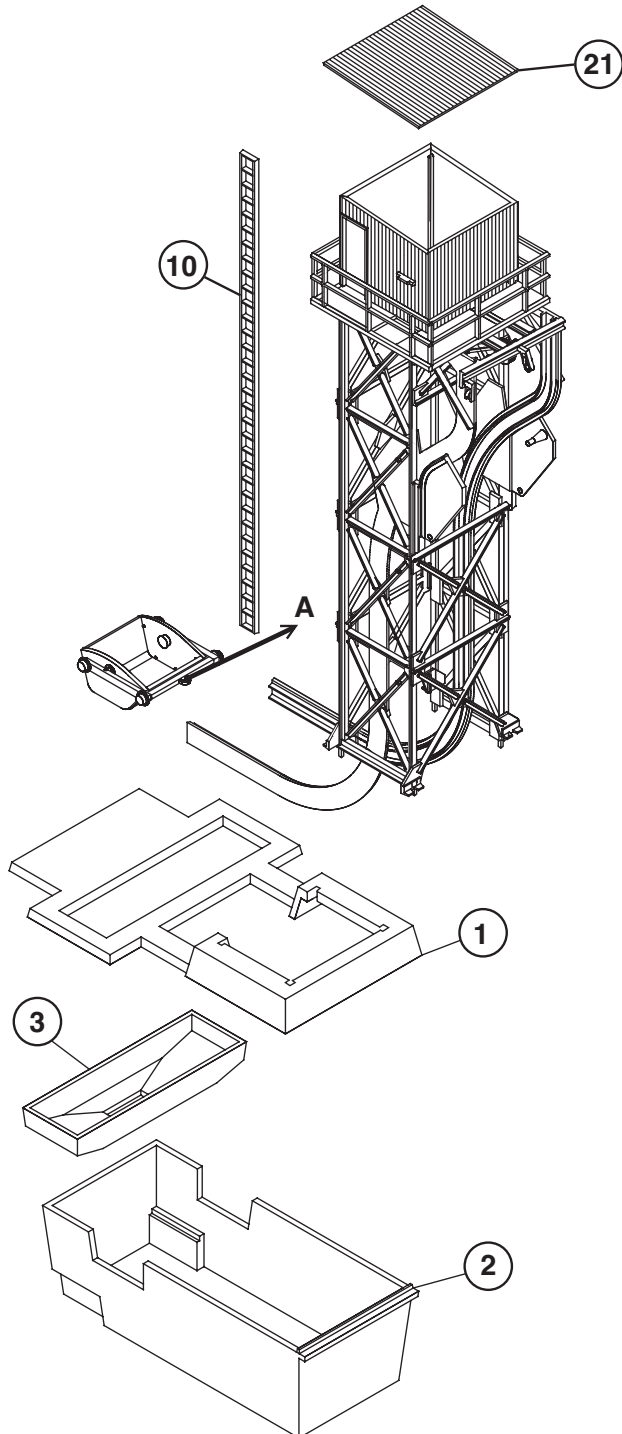
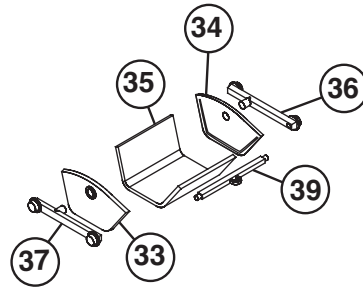

7. Glue the ladder (10) in place.

8. Slide the completed cinder car into the rails on the inside of the sides. You may position it anywhere you wish. However, it was usually stored under the hopper until being used to dump the ash in a waiting car on the other track.

9. Glue the hopper (3) to the bottom of the base (1) and then glue these to the pit (2).

10. Slide the rails on the sides underneath the base and glue the structure into the holes located in the top of the base (1). Glue the roof (21) on the headhouse.

12. Glue the chute (24,25,26,27) together and snap in the lifter (28).

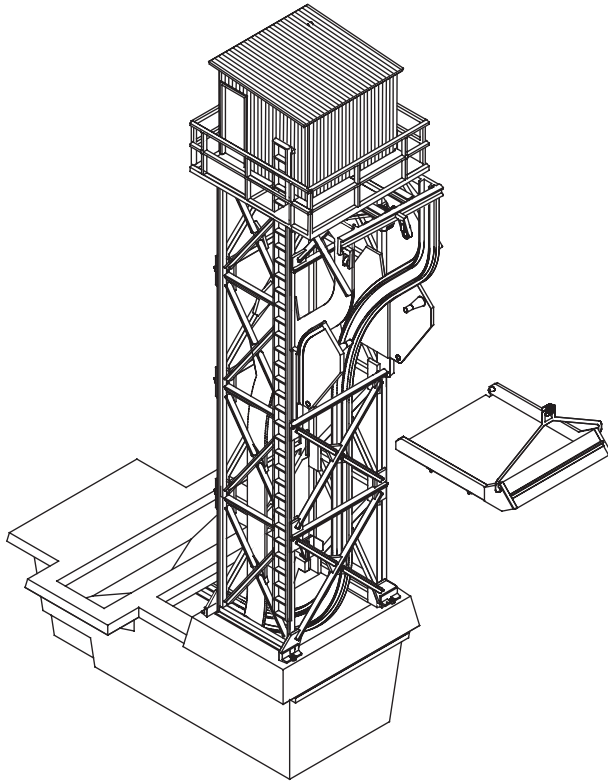
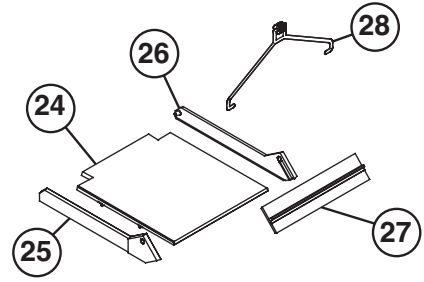

13. Snap completed chute into the holes on the inside of the sides. Note: If you wish to rig the chute follow the chute rigging instructions.

CHUTE RIGGING (step 13)

Use second piece of thread and loop it through the pulley on the lifter (28). Attach one end to the lower hole of the top pulley (31), and run the other end through the upper hole in #31. Continue with the thread through the hole in the side pulley (32). Let the rest of the thread hang down. You can adjust the position of the chute by how high or low you leave the hanging thread.

