



HO Structure Kit

GLACIER INDUSTRIAL SANDS

933-4035

Thanks for purchasing this Cornerstone® kit. All parts are styrene plastic, so use compatible glue and paint to complete your model. Please read the directions and study the drawings before starting. NOTE: Some parts on the sprues are not needed for assembly of this kit, and are not shown on the instructions — use these “extras” for details or kitbashing future projects if desired.

From the beach to the backyard, sand can be found all over the Earth, but it has a lot more uses than we might think. Derived from different types of rock, there are actually many varieties of sand used in making specific types of products. The biggest customers for sand are the makers of building materials, notably concrete and asphalt. The metal casting industry is also a big user, requiring special types of foundry sand to make cores and molds for metal products. Other types of sand are the starting point for glass (including plate glass, containers and fiber glass insulation) and blastings and used to clean metals, but you'll also find sands mixed in with other products such as paint, fertilizers and plastics. One of the more recent developments is its use in hydraulic fracturing, where a pressurized mix of sand (called fracturing or simply “frac sand”) and fluid are used to break rock and improve the flow of oil and gas wells. While sand can be found almost anywhere, not just any sand can be used for any purpose: grains of frac sand for example should be almost pure quartz, nearly round and range in size from about 1/64 to 1/32" (.042 to .084mm). As a result, deposits of a particular type of sand for a product are typically quite some distance from the end-user, and given the volumes required, are shipped by train. While some is shipped in gondolas, to reduce environmental concerns, loss en route from blowing loads and keep the product dry, two-bay covered hoppers are typically used. Processing (sand is actually produced in a variety of ways) and handling also calls for more efficient and environmentally friendly facilities, designed to capture and reduce dust. Typical of loading equipment found at modern quarries and sand mines, structures like your new model are designed to quickly and cleanly speed the transfer of sand from trucks to railcars. This structure can be used by itself at trackside, or combined with other buildings to model a complete operation.

For additional accessories to finish your scene, visit your local hobby dealer, see the current Walthers HO model Railroad Reference Book or visit us online at walthers.com.

INTAKE HOPPER

1. Glue Conveyor Supports (78, 79) to the Conveyor (80). Glue assembly into middle holes on Base (75). Glue Motor Platform (81) and Motor (82) as shown.
 2. Glue Backboard (84), Sideboards (85) and Middle Boards (86) to the Aggregate Bins (83). Glue the Bottom Gates (87) on.
 3. Glue Bin Supports (76, 77) to the outer holes in Base (75). Using the ridges on the side of the Bins to position, glue the Bins to the Supports.
- Optional: To build an embankment leading up to the bins, use Retaining Wall (111) to back it up.

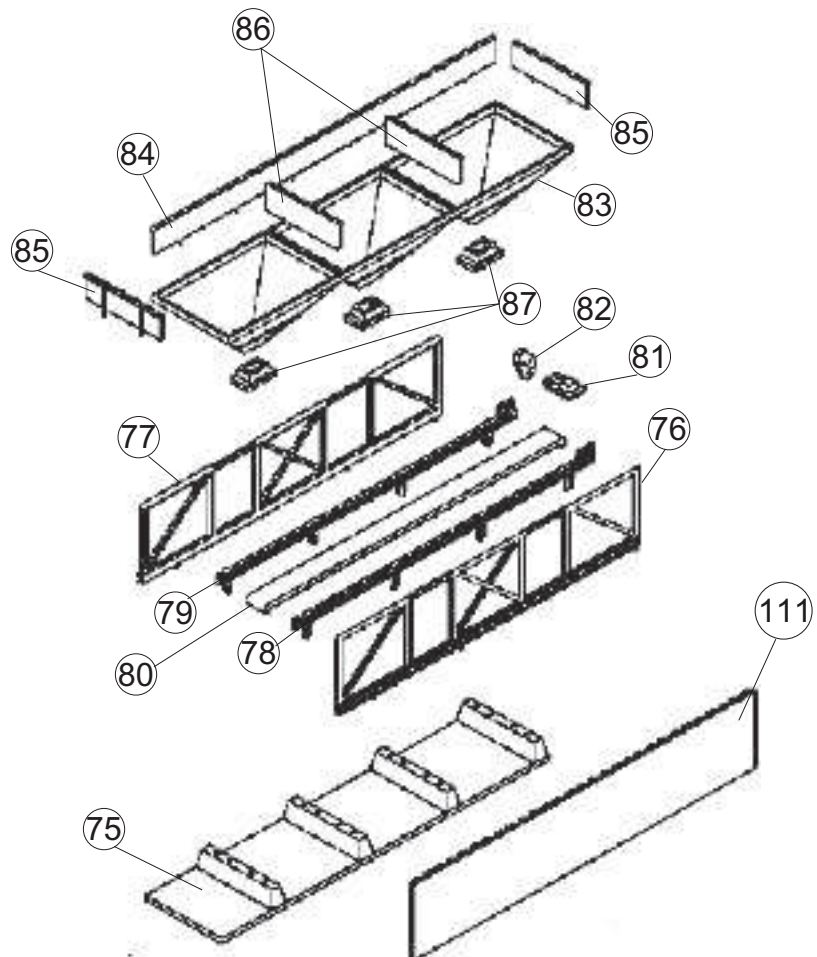

PLATFORM RAILING DETAIL

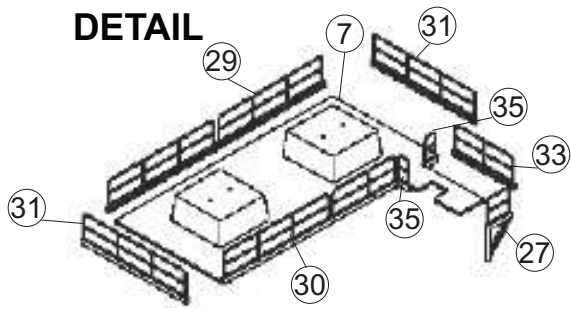

Railcar Loading Area Assembly

1) Note the location of mounting slots on the inside of End Supports (2x 103); glue the tabs of the Cross Braces (2x 105) in place as shown. Glue this assembly (2x 103) to Base Sections (101, 102). With a pencil, mark a line 7/8" (22mm) from each end of the Safety Rail (114). Mark a second line on the bottom of each End Support 1/4" (6.3mm) from the inside edge of the Cross Brace on the side above Base #101. Using your pencil marks as a guide, align the Safety Rail and glue in place. Glue Side Braces (2x 104) to center openings in Base Sections and Cross Braces.

2) Glue Elevator Base (107, 108, 109, 111) to raised area on Base 101 as shown. Note the location of the mounting points for the Handrails and glue Top (110) to elevator base assembly as shown. Glue Inlet Hopper (106) to Front Wall (111). Glue Handrails (2x 113) to Top. Align Ladder with Handrails and glue in place to Right Wall (107).

Silo Assembly

1) Make two silos. Glue six Silo Sections (6) together as shown, and to locating rings on Silo Floor (5).

2) Glue Top Silo Platform (7) to completed silos. Glue Inlet Tops (9) in place to Inlets molded on part 7.

3) Glue Discharge Ports (2x 115) to Silo Floor (5). Glue completed Silo Assembly to top of Rail Car Loading Assembly.

4) Assemble the Top Conveyor (10, 11, 12, 14, 15). Glue the completed assembly to the Inlet holes in Tops (9) as shown. Glue the Motor (16) to the side of part 10 and to the top of part 14.

5) Follow the Platform Railing Detail drawing to complete this step. Glue Platform Handrails (29, 30, 31, 33, 35) on Platform (7). Note: End Handrail (27) will be installed in step 3 in the Elevator Assembly.

Elevator Assembly

1) Glue Elevator Sides (17, 18, 19, 20) together. Glue Top (21) and Slanted Top (22) in place on this assembly.

2) Follow the Elevator Ladder Diagram to complete this step. Glue Platform (24) to Right Side (17). Glue Platform Railings (25, 26) to Platform. Glue Ladders (23, 28, 36) to Side (17) as shown.

3) Test fit (do not glue) Spout (38) inside opening in Elevator Assembly. Carefully align the completed Elevator with the Top Silo Platform (7), and the ridges on Elevator Base Top (110), align the bottom of the Spout (A) with the raised box (A) on part 14 and glue in place. Glue End Handrail (27) to Top Silo Platform as shown in the Platform Railing Detail diagram.

4) Using the raised ridges on Walls (17, 18) as a guide, glue Elevator Platform (37) in place on Elevator. Align the belt guards on Motors (2x 39) with holes in Sides (17, 18), and rest the motors atop the ledge on the Slanted Top 22, then glue in place. Glue Handrails (2x 40, 41) to Platform.

ELEVATOR LADDER DIAGRAM

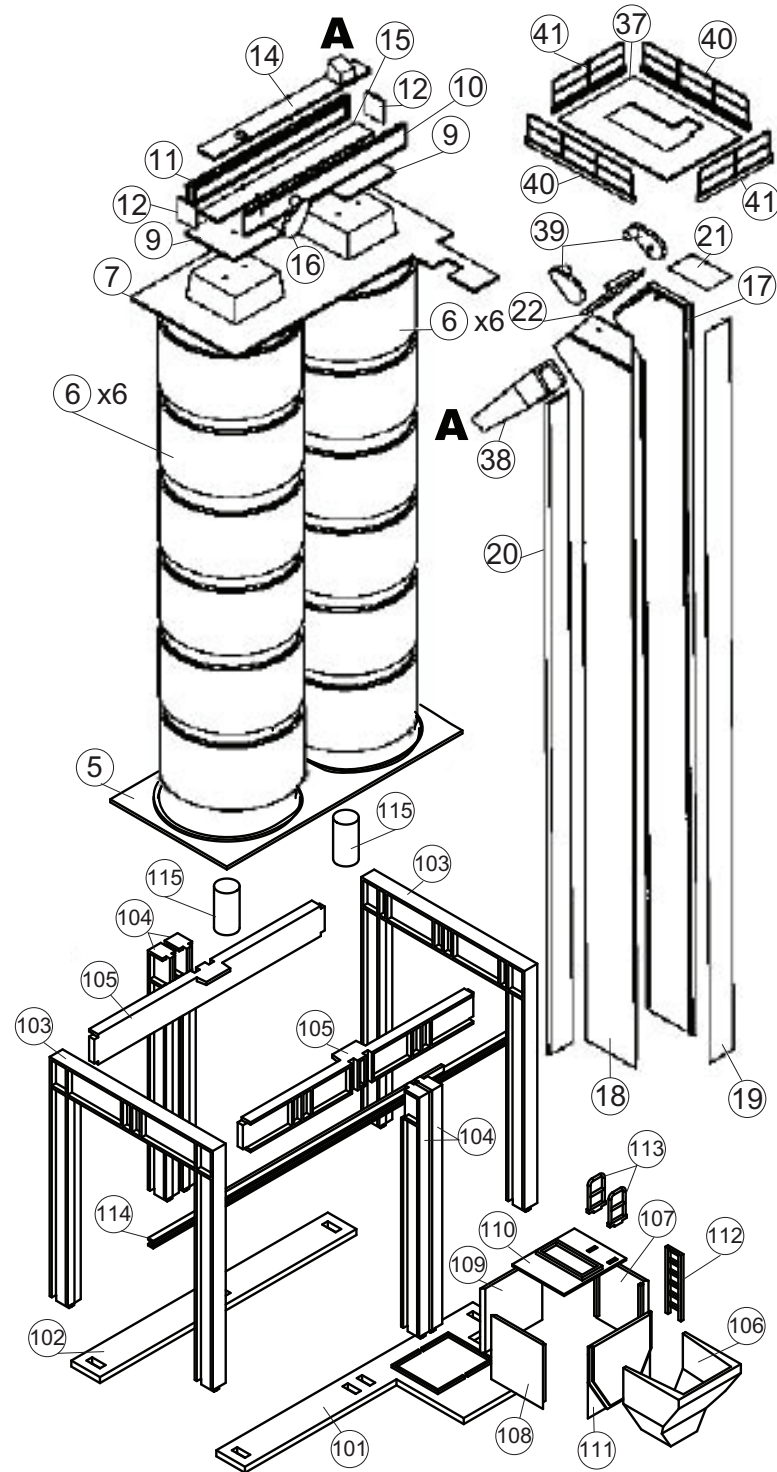
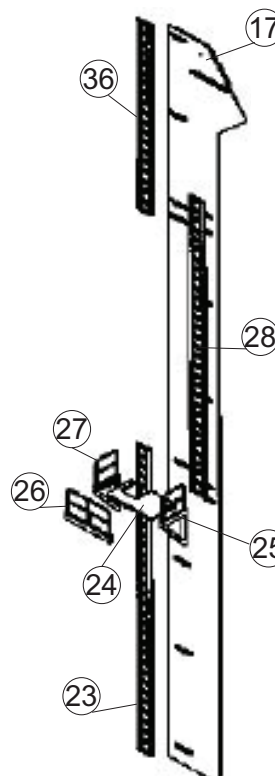

FUEL TANK ASSEMBLY

Glue Tank Halves (100, 101) together, and to Tank Ends (2x 103). Glue Supports (2x 99) to ridges on bottom of Tank Halves. When dry, glue to Tank Base (98) Glue Piping (104, 105) together and to Tank Base. Glue Filler Hatch (102) to Tank.

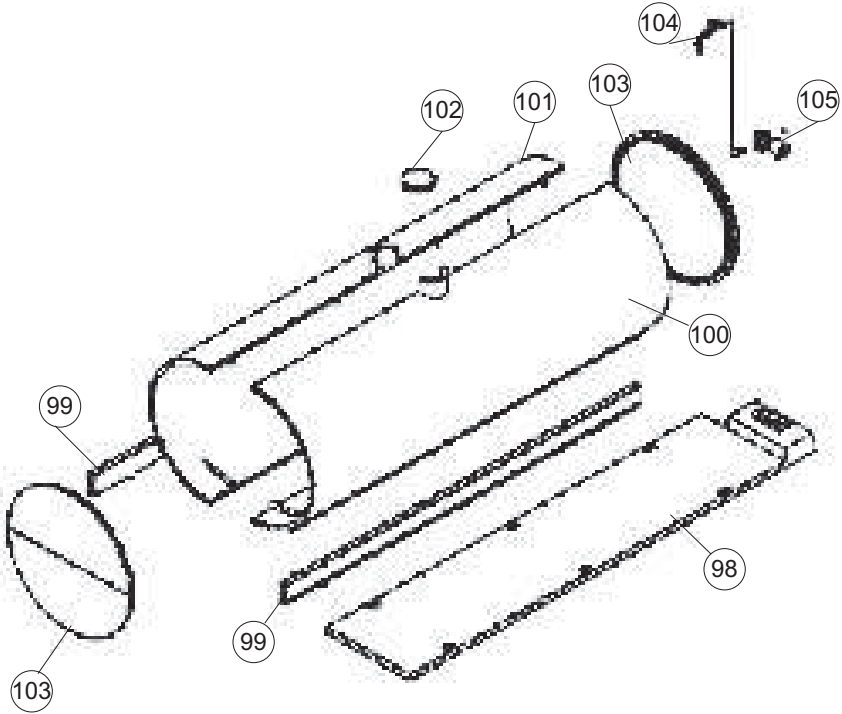

CONVEYOR ASSEMBLY

NOTE that there are two different Conveyor Bases (90, 91); all other Conveyor parts and assembly are identical. Glue Conveyor Sides (88, 89) to Belt (94). Glue Motor (95) to end of Right Side (89) and Pulley (96) to end of Left Side (88). Glue Back Support (93) to holes in front of Base (90, 91). Glue Belt Assembly to end of Back Support and to pegs on Base. Glue Front Support (92) to Back Support (93) and into holes on Sides (88, 89).

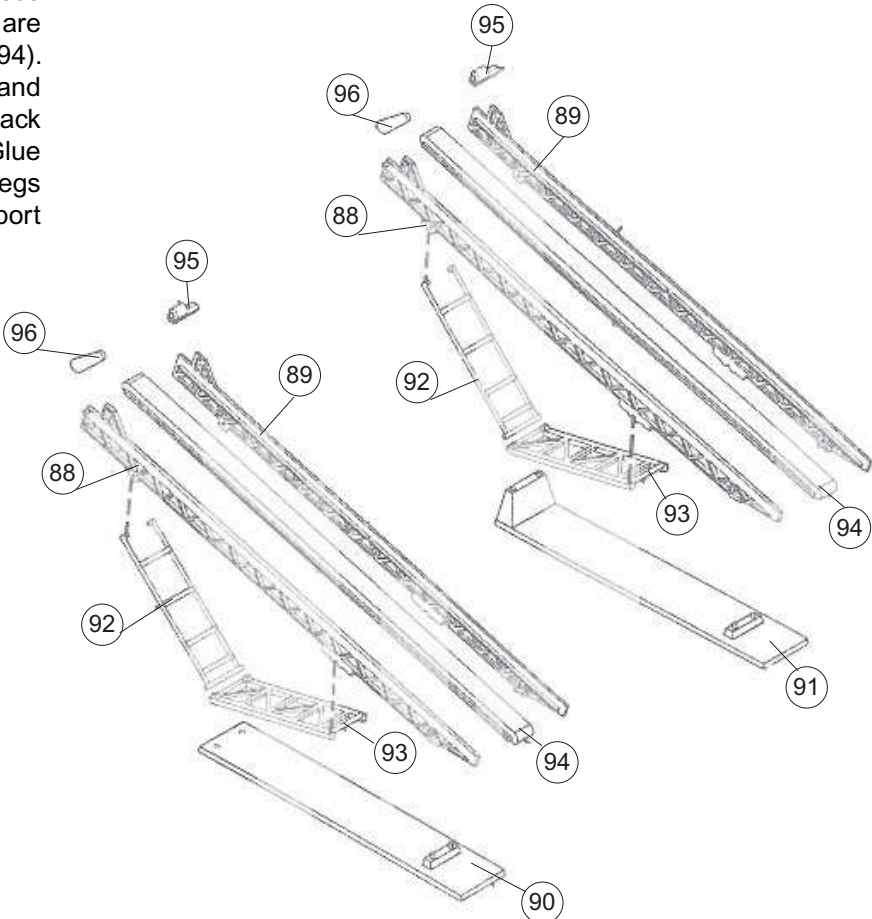

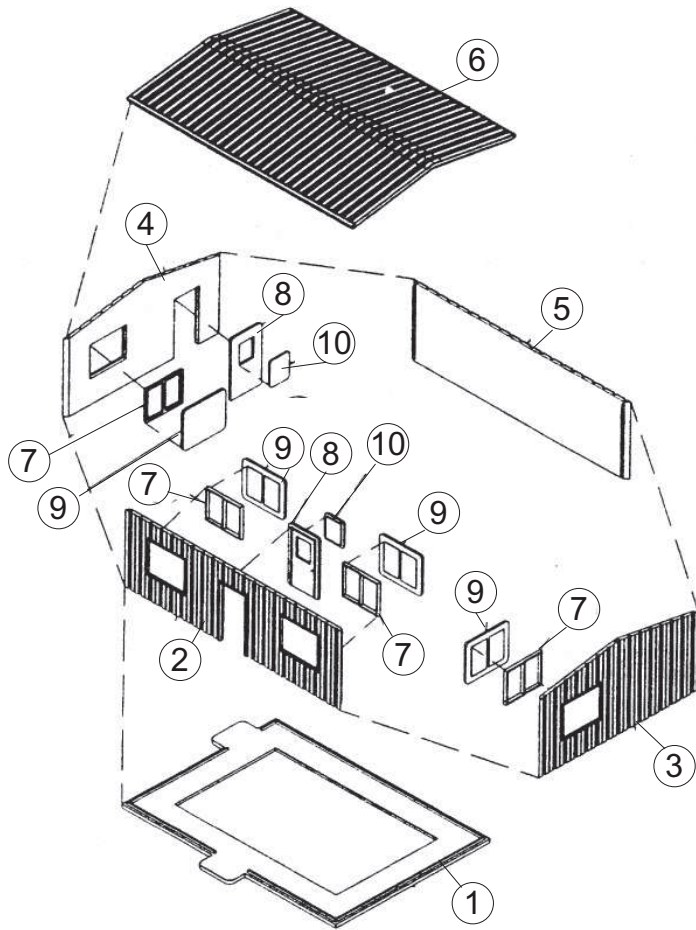

OFFICE ASSEMBLY

Glue Windows (7) and Doors (8) to inside of Walls (2, 3, 4) as shown. Glue Window Glass (9, 10) in Place. Using ridges on Base (1) as a guide, glue Walls (2, 3, 4, 5) in place. Roof (6) can be set in place if you wish to add interior details or lighting (sold separately), or glued in place.

GUARD SHED ASSEMBLY

Note: Although not shown in the box photo, parts for a Guard Shack are provided if you wish to model a main entrance to your operations.

Glue Windows (7) and Door (8) to inside of Walls (12, 13, 14, 15) as shown. Glue Window Glass (9, 10) in Place. Glue Walls (12, 13, 14, 15) together as shown. Roof (16) can be set in place if you wish to add interior details or lighting (sold separately), or glued in place.

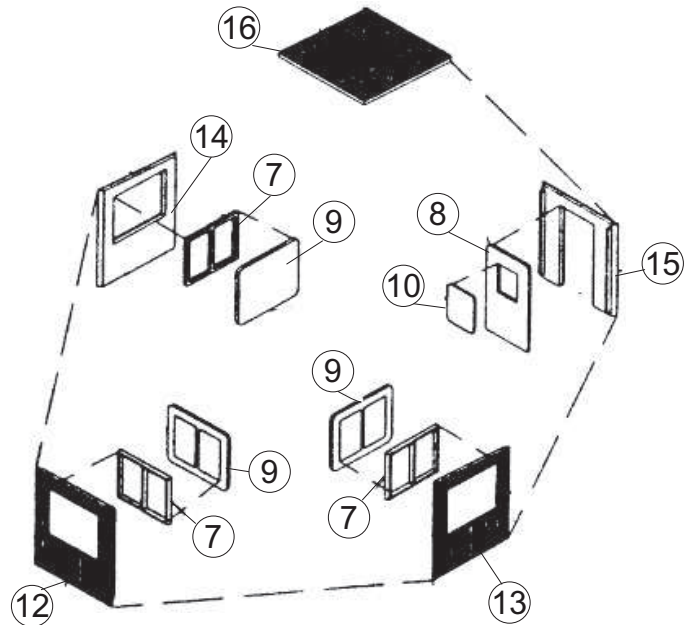

SIGNS

Cut desired signs from printed sheet. Use a small drop of white glue, and attach to Sign to desired location.