



HO Structure Kit TRUCK-SERVED FUEL DISTRIBUTOR 933-4038

Thanks for purchasing this Cornerstone® kit. All parts are styrene plastic, so use compatible glue and paint to finish your model. Please take a few minutes to read these instructions and study the drawings before starting.

Rising transportation costs and lack of easy access to remote oil fields in Pennsylvania lead to development and construction of America's first successful crude oil pipeline in 1865. A trio of steam pumps moved the oil to a bulk terminal, where it was kept in storage tanks until transferred to railroad tank cars for shipment to a refinery. The basic idea was widely copied as the industry grew in the eastern US, fueled by demand for kerosene. As electric lights and automobiles arrived in the early 20th century, gasoline quickly became the dominant product, and long distance crude oil pipelines connecting western oil fields to eastern refineries were built to meet demand. In this same period, smaller diameter pipelines were built especially to move finished petroleum products between refineries and outlying terminals. From here, tank cars moved by train to bulk oil dealerships in smaller towns and cities. These smaller operations, shoehorned alongside the tracks in industrial areas where complaints about noise and odor weren't likely, reloaded gasoline and other products in tank trucks for delivery to customers. By the 1960s more and more companies were using semi tank trucks to speed delivery from bulk terminals to their smaller dealers and direct to customers, while others were forced to convert to truck delivery as local railroad lines were abandoned. Always conscious of their public image, many oil companies took advantage of the changes to modernize and update their dealerships with new offices and truck loading racks. Many are still going strong today. For additional accessories to finish your scene, visit your local hobby dealer, see the current Walthers HO Model Railroad Reference Book, or visit us online at walthers.com.

Loading Rack Assembly

Some additional parts are included but aren't needed to complete your model. These can be used as extra details on future projects.

1) Glue Motor Platforms (2x 114) on the first and third notches from the right on the raised supports on Base (101). Glue Motor/Pumps (2x 115) to Platforms.

2) Note that the mounting points are offset on Meter Platform (108): glue Meters (2x 113) to the first and third mounting points from the right. Make sure the angled notch in Floor (107) is at the rear, and glue Meter Platform to Floor. Align Elbow Pipes (2x 118) with larger mounting holes at front of floor, and glue to Floor and Meters.

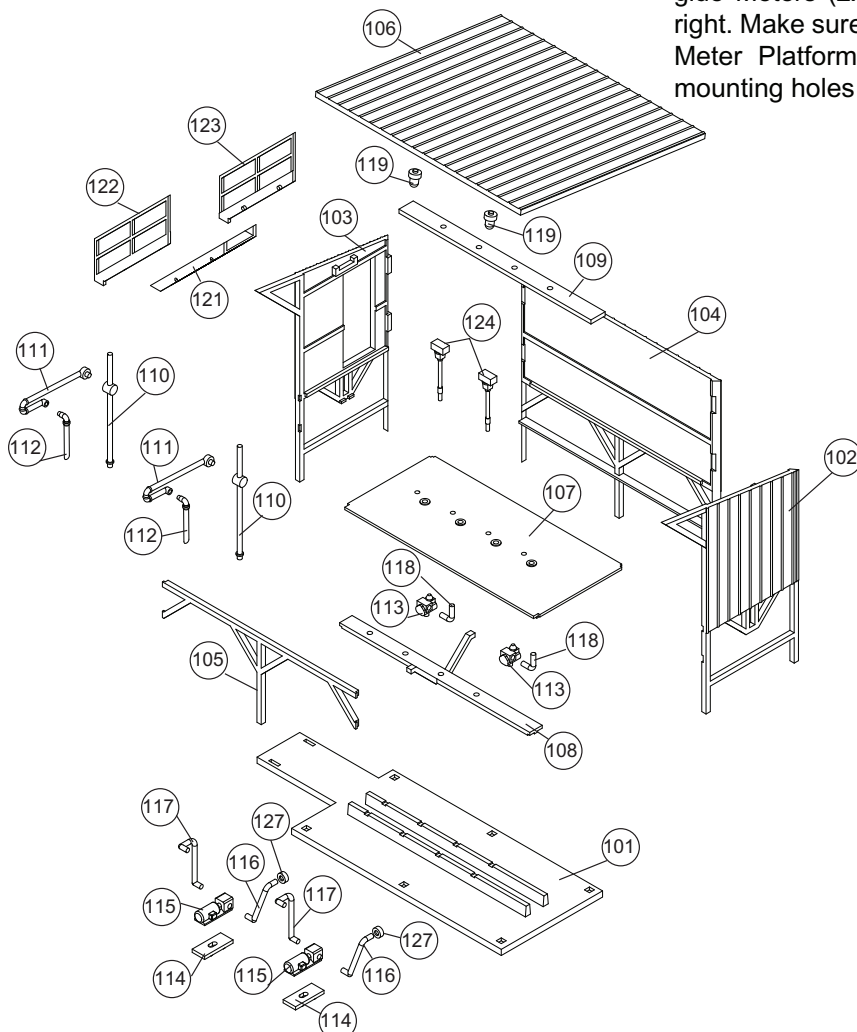

3) Glue Side Walls (102, 103) and Back Wall (104) to mounting points on Base (101). Glue Floor from Step Two to completed wall assembly. Note the small tabs on the ends of Brace (105) – carefully remove the Brace from the sprues to avoid damaging these tabs – then glue to notches in Side Walls and tab on Meter Platform.

4) Insert a Meter Panel (2x 124) through the Floor until it touches the cone-shaped connector on top of each Meter and glue in place. Glue Outlet Pipe (2x 117) to mounting hole on left side of each Motor/Pump and to left side of each Meter.

5) Insert, but do not glue Vertical Loading Pipes (2x 110) through openings in Loading Pipe Top Retainer (109) and holes in Floor; with careful assembly, you can turn the pipes for added realism. Glue Retainer to notches at top of Side Walls. Glue Loading Arms (2x 111) at a slight upward slightly (the angle can vary) to Loading Pipes. Glue Nozzles (2x 112) so they hang vertically from Loading Arms.

6) Glue Lights (2x 119) to inside of Roof (106). NOTE: Test fit Roof to Walls — if Loading Pipes interfere with the Roof, trim as needed before gluing Roof in place. Glue Hand Rails (122, 123) to Stairs (121). Glue Stair assembly to doorway opening on Side Wall and notches in Base.

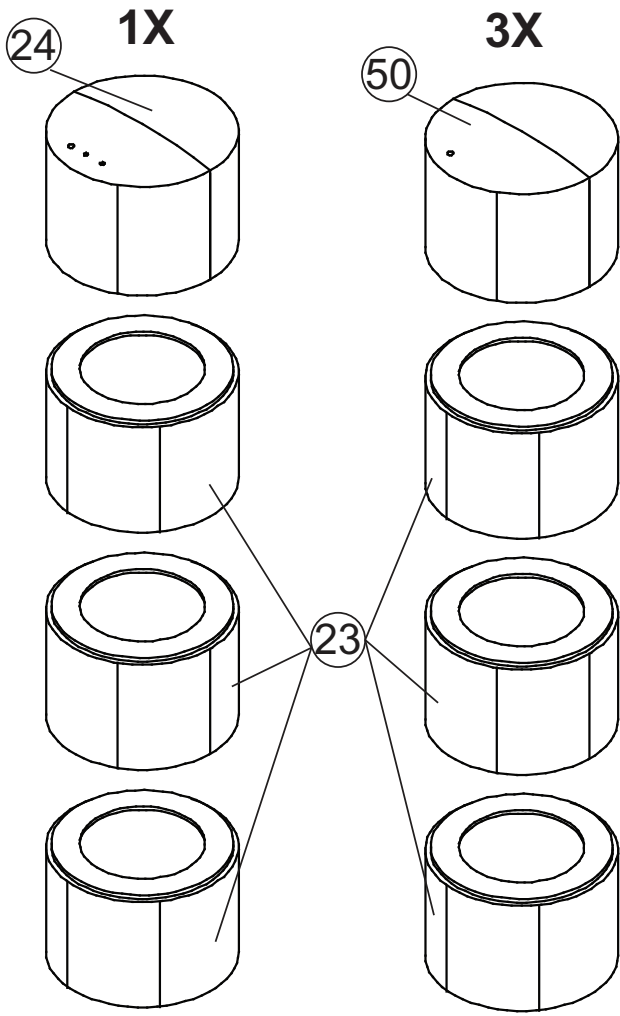

Storage Tank Assembly

Before starting, note how the seams on each set of tank sections are aligned; real tanks are built this way for added strength, and careful assembly will result in a more realistic model. This kit includes four tanks, three standard and one with an access ladder.

Standard Tanks

Make three identical tanks following these steps. Glue three Tank Sections (23) together as shown. Use Top Sections (3x 50) with a single mounting point for this step, and glue as shown to assembled sections. Glue Vent (25) to mounting point in Top Section.

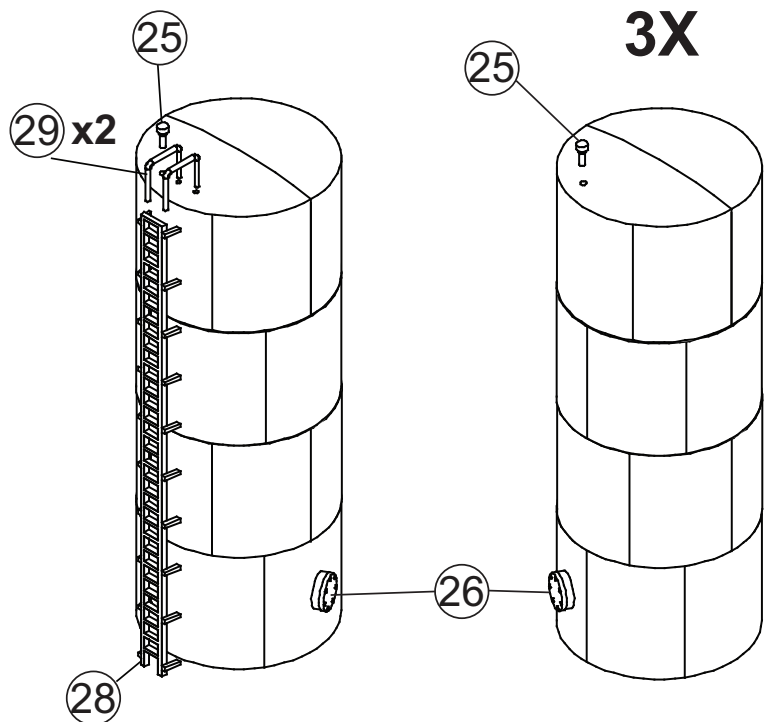

Access Tank w/Ladder

Glue three Tank Sections (23) together as shown. Use Top Section (50) with three mounting point for this step, and glue as shown to assembled sections. Glue Handrails (2x 29) to the two mounting points on the right side of the Top Section. Carefully remove Ladder (28) from sprues, and glue to Handrails and side of tank. Glue Vent (25) to remaining mounting point (far left) in Top section.

Berm Assembly

If you wish to paint or detail your Berm, the prototypes are covered with washed gravel.

Glue Tank Outlet Piping (120) to Berm (31) as shown. Glue a Flange (2x 127) to the end of each outlet manifold as shown.

Glue the four tanks to the raised rings inside the Berm with the vents facing the outside corners as shown. Glue an Inspection/Cleanout Hatch (4x 26) to each tank, centered on a lower panel as shown.

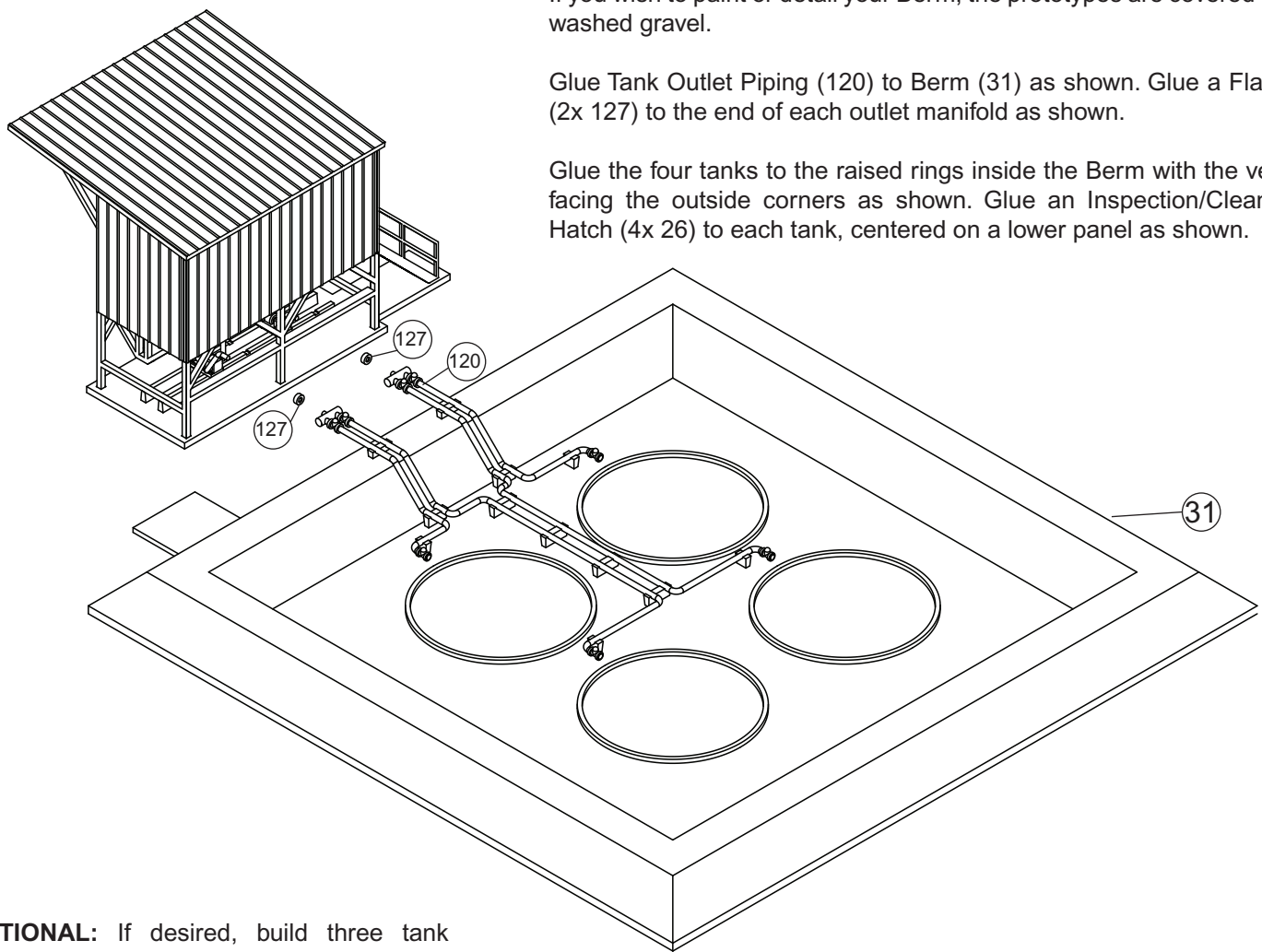

OPTIONAL: If desired, build three tank access platforms by gluing Handrails (2x 30) to sides of Walkway (27). Center the walkways on the tops of adjoining tanks, and glue in place.

Glue Berm Walkways (2x 125) to each side of Platform (126) and to Berm as shown.

Glue Loading Rack Inlet Pipes (2x 116) to right side of Motor/Pumps (2x 115) on Loading Rack; before the glue dries, align both Pipes with the Flanges but don't glue them together — your model will be easier to handle and install on your layout as two separate assemblies.

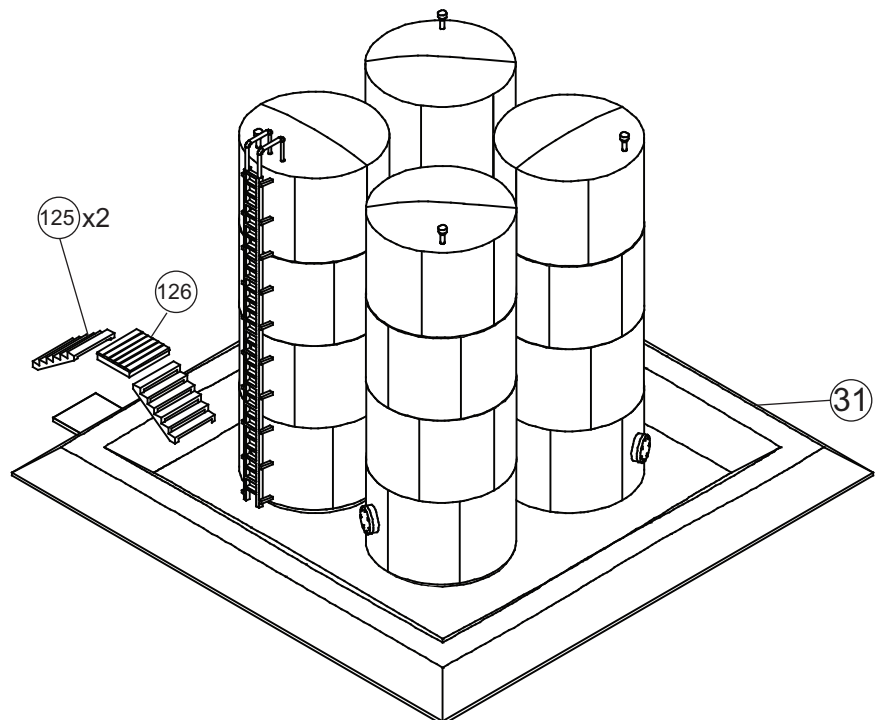
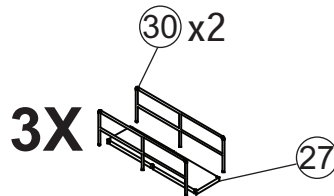

DECALING

1. After cutting out the decal, dip in water for 10 seconds, remove and let stand for 1 minute. Slide decal onto surface, position and then blot off any excess water.
2. Lightly brush Micro Sol® on top. This will soften the decal allowing it to conform to irregular surfaces. DO NOT TOUCH DECAL while wet!
3. When the decal is thoroughly dry, check for any trapped air bubbles. Prick them with the point of a small pin or hobby knife blade and apply more Micro Sol®.

Office Assembly

Glue Windows (7) and Doors (8) to inside of Walls (2, 3, 4) as shown. Glue Window Glass (9, 10) in Place. Using ridges on Base (1) as a guide, glue Walls (2, 3, 4, 5) in place. Roof (6) can be set in place if you wish to add interior details or lighting (sold separately), or glued in place.

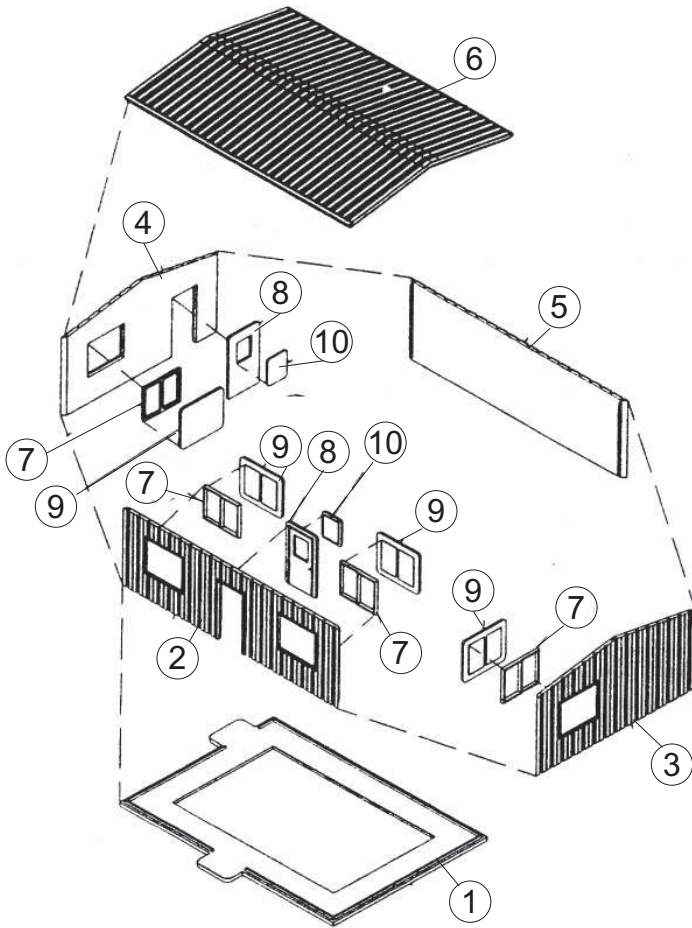

Chain Link Fencing

1) For easier construction, paint all parts silver or aluminum (paint sold separately) before beginning assembly. Select a location for the fence and determine the spacing of the poles, starting from a corner — poles are usually no more than 10' (3m) apart, and should be installed with the angled top facing outward.

2) Drill mounting points for each Pole with a #62 drill bit (sold separately), apply glue and push poles in place down to the bottom collar.

3) Measure the distance between each corner post. Cut two pieces of wire (eight total) to fit between each corner post — wires between access gates only: add 1/16" (1.5mm) to the overall length and bend approximately the last 1/16" (1.5mm) of each wire at a right angle as shown. Align wires below the upper and above the lower collars as shown, and glue in place with cyanoacrylate (CA) type adhesive (sold separately) — wires between access gates only: make sure the bends face upward and extend about 1/16" (1.5mm) beyond the gateposts. Align Hinges on Gates as shown and glue in place. When dry, slip Hinges over mounting wires.

4) Mount the chain link material on a sheet of contact paper (sold separately) and cut into uniform strips, each 15/16" (23.8mm) wide. Starting at a corner, work slowly and carefully align the edge of the material on the edge of the Pole, and glue in place using CA adhesive — a slow-setting formula will give you time to make adjustments. When dry, carefully pull the material taut as far as the next Pole, and apply small amounts of CA along the top and bottom wires. Repeat for each Pole.

