



HO Structure Kit **DIAMOND COAL CORP.** 933-4046

Thanks for purchasing this Cornerstone kit. All molded parts are styrene, so use compatible glue and paint to complete your model. If you wish to paint your structure, you may find it easier to do so before beginning assembly. Structures of this type were typically covered with galvanized steel panels, which take on a weathered gray and rusted appearance over time. Windows were often painted silver to match the rest of the building while structural steel beams were black. To use the printed-paper signs, carefully cut each sign from the sheet and attach with white glue. The box photo can be used as a placement guide. With minor modifications, the conveyor can be installed at various angles to simulate coal coming from an underground mine, or installed as a level conveyor to simulate a long-distance unit serving an unseen mine.

While Native Americans used coal for various purposes, commercial production didn't begin in America until 1748 near present-day Richmond, Virginia. As the price of firewood soared in cities, demand grew for anthracite (hard coal), but later expanded to include bituminous (soft coal) and eventually metallurgical or coking coals used for making iron and steel. As the mines were located away from their customers, many began shipping coal by barges and boats. Most were too far from waterways, and had to rely on slow and expensive wagon shipments down to the docks. Canals were touted as an answer, but weren't always practical, so many coal companies then built and operated their own small railroads to reach the rivers. As the railroad network and the coal industry expanded, specialized facilities for washing, breaking, sizing and loading coal into waiting hopper cars were built at track-side. Coal was brought out of the mine head in small cars that were "tipped" to empty them, and the trackside loading facilities came to be known as "tipples." While some customers bought coal as-is (run-of-mine coal), most was first "washed" to remove soil or rocks, then crushed to a specific size, ranging from tiny "barley" and "rice" to baseball-sized lumps known as "stove." Crushing and grading also produced coal dust and tiny pieces known as "slack," which was routed into a separate storage bin so it could be bagged and sold for banking fires at night or processed into briquettes. Inside the tipple, screened coal was routed via conveyors and loaded into waiting hoppers by gravity. Coal traffic was a highly specialized operation. Empty cars would be pooled in a central yard then delivered to outlying tipples by "mine runs" or "mine shifters" that would pick up loaded cars for the trip back to the home terminal. Tipples could be found alongside busy mainlines, but many were located on remote branches, which necessitated engines backing down with empties then running around the train for the return trip. Many smaller tipples operated into the 1980s when low-sulfur western coal began dominating the American market. At the same time individual car loading was being replaced by dedicated unit trains served by flood loaders, so many older tipples were closed or replaced. Sized to fit almost any layout, your new model is perfect for modeling these small loading operations found in many parts of the US. See your local hobby dealer, check out the current Walthers Model Railroad Reference Book or visit us online at walthers.com for additional figures, scenery materials, vehicles and other details to complete your new model.

NOTE: If you wish to paint your model, do so before starting construction.

DOORS & WINDOWS

1) Acetate is provided for window glass. Cut pieces slightly larger than the Windows and glue in place with white glue. Glue Windows and Doors to the the inside of each Wall as shown:

Tipple:

- Right Wall (5): Windows (9x 39)
- Front Wall (3): Windows (5x 39)
- Left Wall (4): Windows (4x 39), Machinery Access Door (36)
- Small Rear Wall (7): Large Window (38)
- Lower Left Wall (11): Windows (2x 39), Small Access Door (36), Large Access Door (35)
- Lower Right Wall (12): Large Windows (2x 38), Large Access Door (35)

Loader:

- Front Wall (9): Windows (3x 39)
- Left Wall (8): Large Windows (3x 38)
- Right Wall (10): Windows (2x 39)

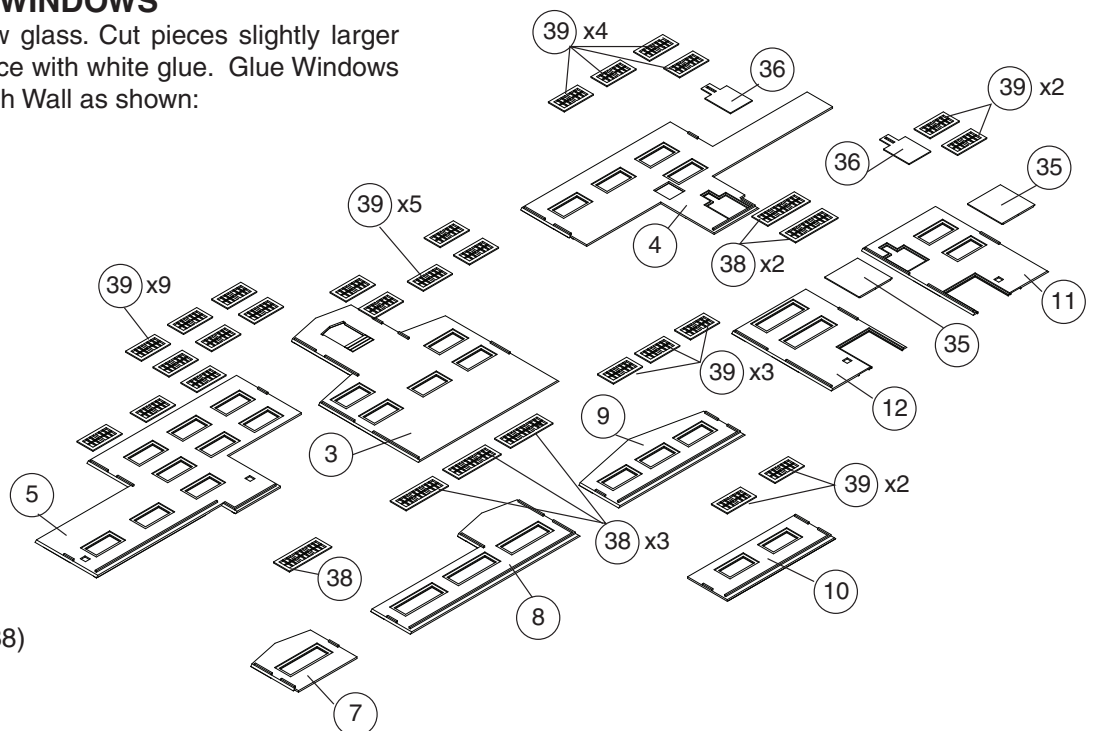

LOADING PLATFORM

- 1) Glue Floor Supports (3x 19) to underside of Floor (21).
- 2) Glue Center Support Braces (2x 40) to outside of center support; glue Left Support Braces (2x 42) and Right Support Braces (2x 41) to outside edges as shown.
- 3) Slip a Chute Bracket (2x 44) over each chute opening and glue to raised lip on Chute (2x 43).
- 4) Note locating pins on end of Chutes fit in openings on the top of the Floor. NOTE: If installing Chutes in open position, make sure there is sufficient clearance below for cars and engines on track before gluing in place. Glue Chutes to Floor in open or closed position as desired.

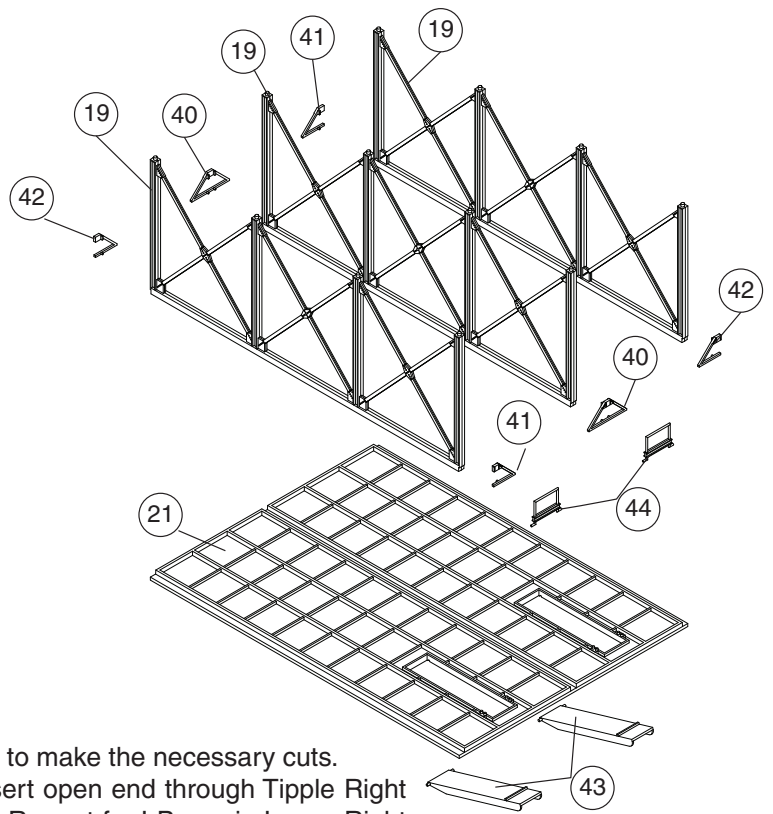

TIPPLE

PLEASE NOTE: The Conveyor can be built to simulate coal arriving from a "drift mine" where the seam is worked horizontally, or a "slope mine" where coal is reached by an inclined shaft. For a drift mine, no modifications are needed. For a slope mine, three molded cut lines are provided on the back of the Tipple Front Wall (3) directly below the conveyor access opening. Remove one, two or three of these sections to install the finished conveyor at the desired angle before starting assembly of the Tipple. Using the molded cut lines as a guide, work carefully and use a razor saw or sharp hobby knife to make the necessary cuts.

- 1) Note the raised pad on one end of the I-Beam (37) and insert open end through Tipple Right Wall above Machinery Access Door. Glue in place from inside. Repeat for I-Beam in Lower Right Wall.
- 2) Using raised ridges as a guide, glue Tipple Front Wall (3) to Base (1). Glue Tipple Right (5) and Left (4) Walls to Base and at inside corners of Front Wall. Glue Rear Tipple Wall (6) to Base and at inside corners of Side Walls.
- 3) Glue Lower Left Wall (11) and Lower Right Wall (12) to Base and at inside corners of Front and Rear Walls.
- 4) Glue Floor (22) to raised ridges on Rear Wall and Left and Right Walls. Make sure corrugations are facing out, and glue Small Wall Filler (20) to raised ridges on Floor and Left and Right Walls.
- 5) Glue Small Rear Wall (7) to raised ridges on Left and Right Walls.

LOADER

- 1) Glue Center and Left Platform Supports to Platform Pilings (2x 2). Glue right Floor Supports to Pilings on Base (1) as shown.

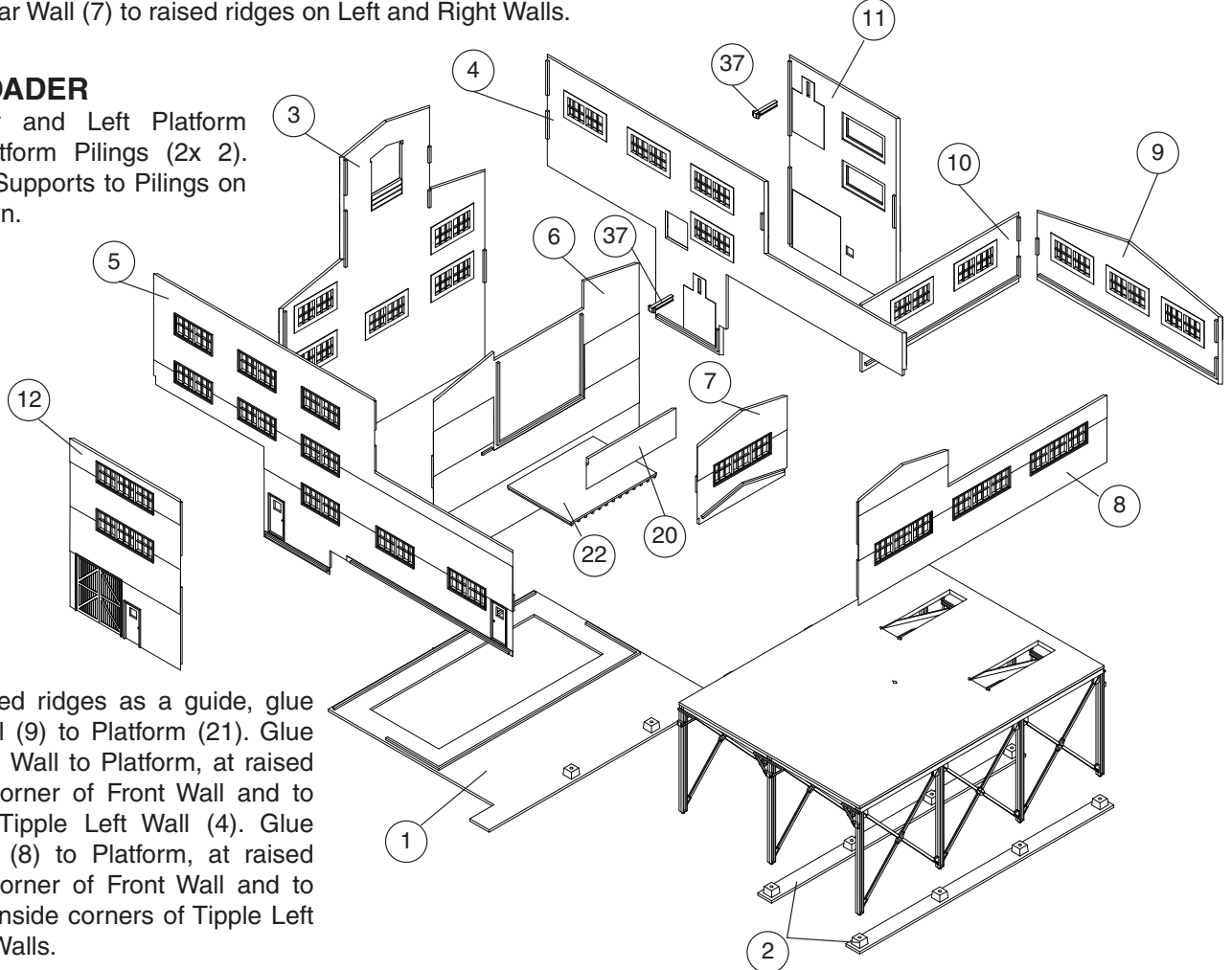

- 2) Using the raised ridges as a guide, glue Loader Front Wall (9) to Platform (21). Glue Loader Right (10) Wall to Platform, at raised ridge on inside corner of Front Wall and to raised ridge on Tipple Left Wall (4). Glue Loader Left Wall (8) to Platform, at raised ridge on inside corner of Front Wall and to raised ridges on inside corners of Tipple Left (4) and Right (5) Walls.

ROOFS

1) Glue Upper Tipple Roof (2x 13) to top of Tipple. Glue Lower Right Tipple Roof (19) and Lower Left Tipple Roof (18) to Lower Tipple.

1) Glue Upper Loader Roof (2x 14) to upper level of Loader. Glue Right Loader Roof (16) and Left Loader Roof (15) to Loader.

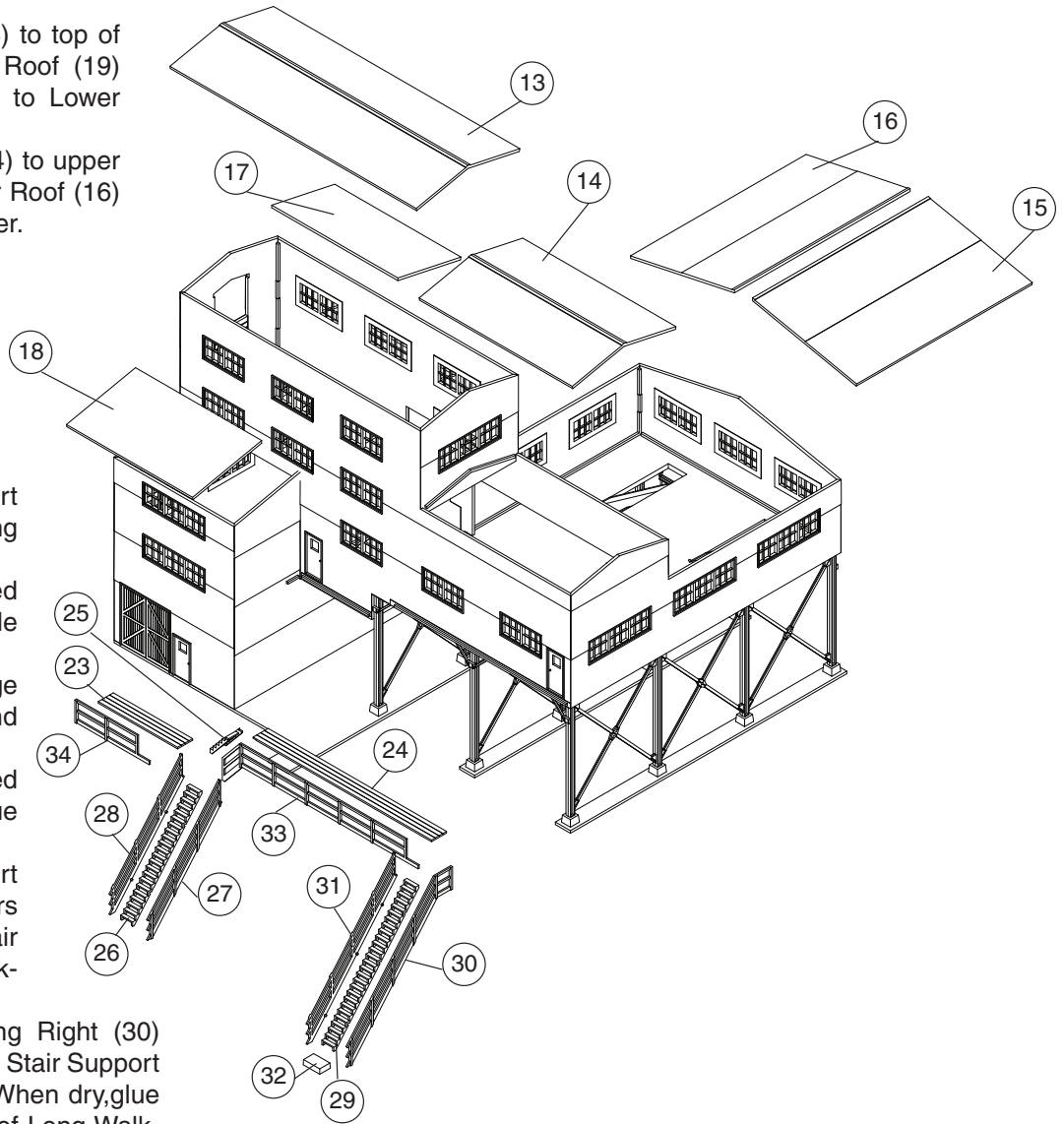

STAIRS

1) Glue Short Railing (34) to Short Walkway (23). Glue Long Railing (33) to Long Walkway (24).

2) Glue Short Walkway to raised ridge below entry door on Tipple Right Wall.

3) Glue Small Stairway (25) to edge of Long Railing and to Long and Short Walkway as shown.

4) Glue Long Walkway to raised ridge on Tipple Right Wall, and glue Small Stairs to Short Walkway.

5) Glue Short Left (28) and Short Right (27) Handrails to Short Stairs (26). When dry, glue Short Stair assembly to right end of Short Walkway as shown.

6) Glue Long Left (31) and Long Right (30) Handrails to Long Stairs (29). Glue Stair Support (32) to lower end of Long Stairs. When dry, glue Long Stair assembly to right end of Long Walkway as shown.

LARGE MINE CONVEYORS

1) Using raised ridges as a guide, glue Conveyor Side Walls (2x 46, 2x 47) to Conveyor Floors (2x 45) as shown.

2) Glue completed assemblies together at inset mounting points on Walls. Glue Conveyor Roofs (2x 48) to completed Walls.

3) PLEASE NOTE: For a drift mine conveyor only, note the raised ridges on the Conveyor Floor and the top brace of the Conveyor Supports (2x 49). Glue Supports to Floor where sections meet and at the far end of the Conveyor as shown.

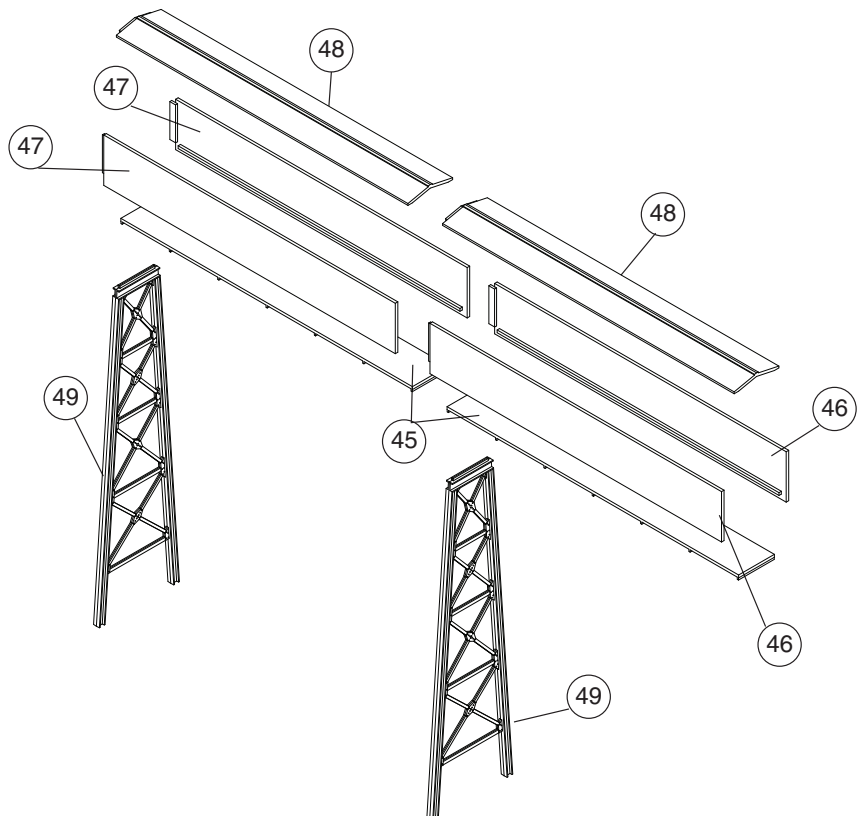

SLACK BIN

1) Glue Support Beams (2x 51) to Base (50) as shown. Align the middle crosspiece of both Cross Braces (2x 52) with the lower crosspiece on the Support Beams as shown and glue in place.

2) Glue Discharge Outlet (56) to Lower Bin Section (53). Note the position of the larger pad on the Center Bin Section (54) and glue to Lower Bin section. Note the alignment pins and inserts, and glue Bin Roof (55) to top of Center Section. When dry, glue completed Bin mounting pads to top of each Support Column.

3) Cut acetate slightly oversize and glue in place behind windows in Machinery Shed Walls (58, 59, 60).

4) Using raised ridges as a guide, glue Machinery Shed Wall (58) to inside corners of Right (62) and Left (59) Machinery Shed Walls. Glue Shed Support (61) to raised ridges inside lower edge of each Side Wall. Glue Front Machinery Shed to Shed Support and at inside corners of both Side Walls. Glue Shed Roof (64) to Walls. Glue Machinery Shed to completed Bin Assembly.

5) Note the four mounting pins on the inside edge of the Lower Walkway (67), and glue these to top of the middle horizontal brace on Cross Brace. Glue Lower Walkway Supports (2x 57) to bottom of Lower Walkway and Cross Brace.

6) Glue Upper Walkway (63) to open area on lower edge of Shed Front Wall. Note the open end of the Upper (long) Access Ladder (71) is the bottom and the small mounting tabs, which should be on the left side for correct installation. Glue Upper (long) Safety Cage (72) to mounting points on front of Upper Ladder. Insert Upper Ladder through opening in Upper Walkway. Note the attachment point on the back of the Ladder and glue to corner support on Bin. For a sturdier assembly, apply a tiny drop of glue to each side of the Ladder where it meets the underside of the Upper Walkway.

7) Glue Upper Walkway End Railings (2x 74) to sides and Long Railing to front of Upper Walkway.

8) Place Rear (69) Lower Walkway Railing behind Long Ladder and glue to Walkway. Glue End Railing (70) and Front Railing (68) to Lower Walkway.

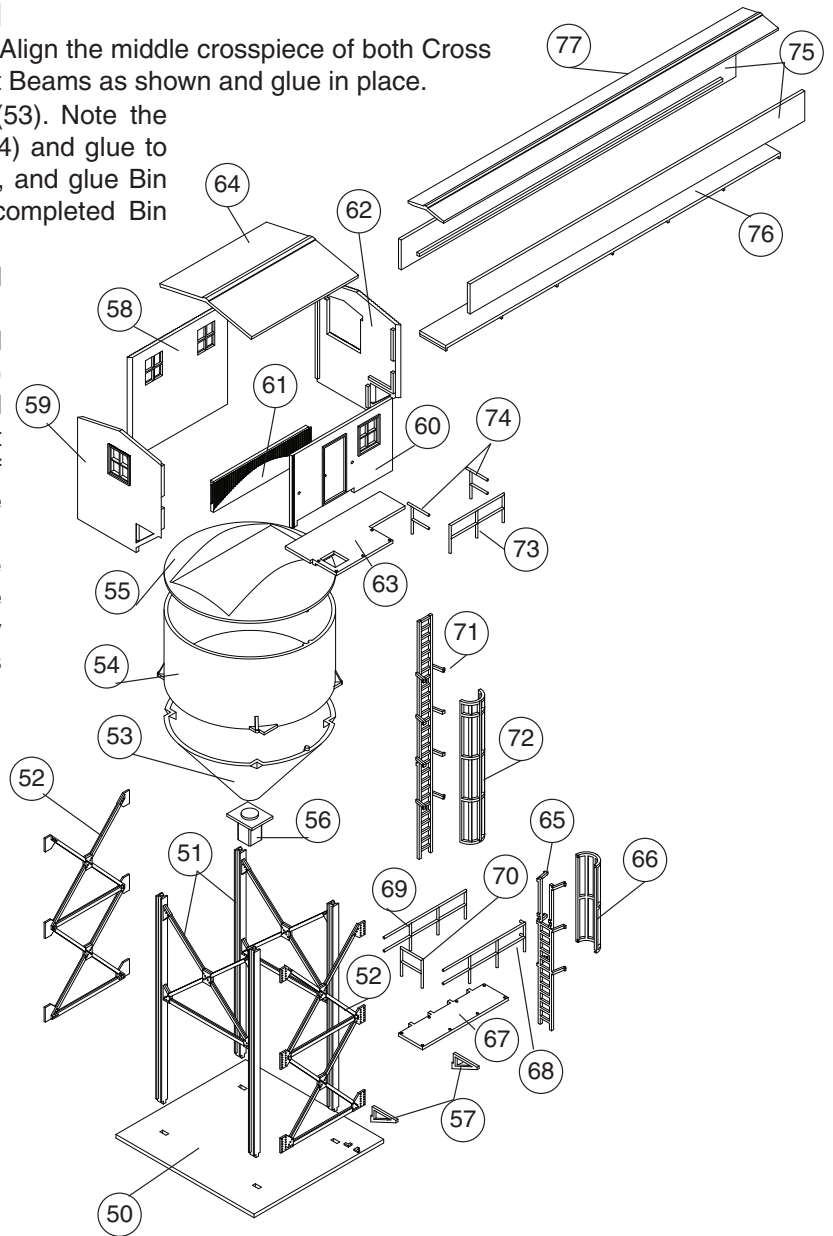

9) Note the open end of the Lower (shorter) Access Ladder (65) is the top. Glue Lower (short) Safety Cage (66) to mounting points on front of Lower Ladder. Glue Lower Ladder to raised points on Base and to edge of Lower Walkway as shown.

10) Using raised ridges as a guide, glue Bin Conveyor Sidewalls (2x 75) to Bin Conveyor Floor (76). Glue Bin Conveyor Roof (77) to Bin Conveyor Sidewalls. Insert, but do not glue, finished conveyor into Machinery Shed Right Wall and to opening in Left Tipple Wall; the conveyor will slope upward from the Tipple to the Shed.

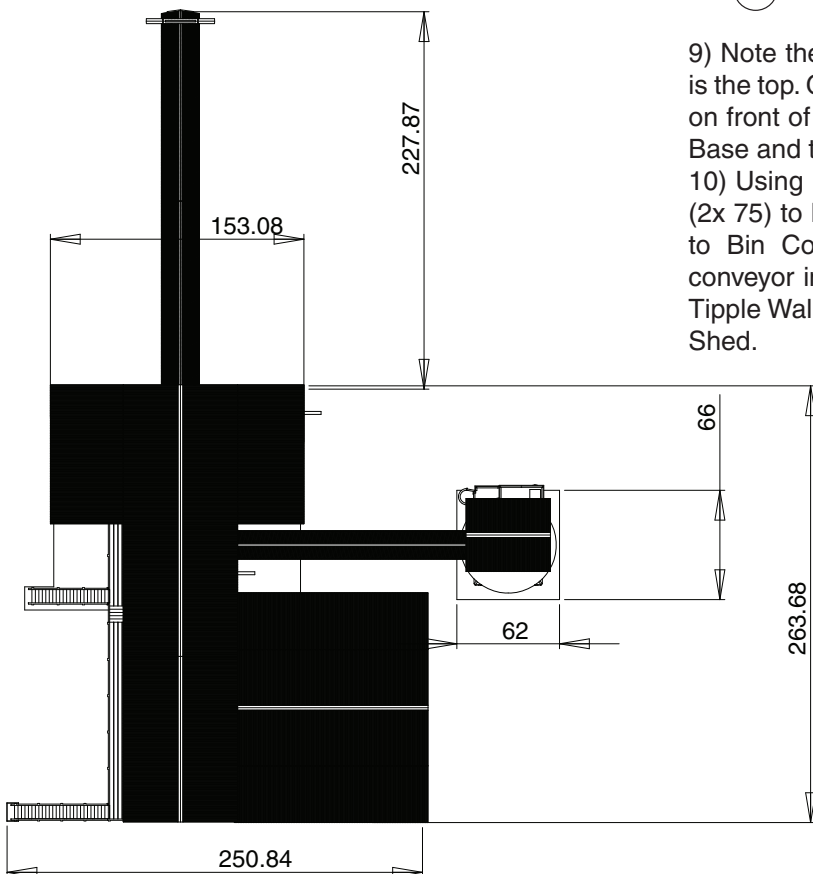

PAPER SIGNS

Trim out the paper sign with sissors or sharp knife. Brush a light coat of white glue over the back of the sign. Place into position and press permanently into place with your fingers.